

SUZUKI

GSF400

Bandit

SERVICE MANUAL

99500-33022-03E

(英)

FOREWORD

The SUZUKI GSF400/BANDIT has been developed as a new generation motorcycle. It is packed with highly advanced design concepts including a liquid cooling system, a new highly efficient combustion system (TSCC) and a fully transistorized ignition system. Combined with precise control and easy handling the GSF400/BANDIT provides excellent performance and outstanding riding comfort.

This service manual has been produced primarily for experienced mechanics whose job is to inspect, adjust, repair and service SUZUKI motorcycles. Apprentice mechanics and do-it-yourself mechanics, will also find this manual an extremely useful repair guide. This manual contains the most up-to-date information at the time of publication. The rights are reserved to update or make corrections to this manual at any time.

IMPORTANT

All street-legal SUZUKI motorcycles with engine displacement of 50cc or greater are subject to Environmental Protection Agency emission regulations. These regulations set specific standards for exhaust emission output levels as well as particular servicing requirements. This manual includes specific information required to properly inspect and service GSF400/BANDIT in accordance with all EPA regulations. It is strongly recommended that the chapter on Emission Control, Periodic Servicing and Carburetion be thoroughly reviewed before any type of service work is performed.

Further information concerning the EPA emission regulations and U.S. SUZUKI's emission control program can be found in the U.S. SUZUKI EMISSION CONTROL PROGRAM MANUAL/SERVICE BULLETIN.

SUZUKI MOTOR CORPORATION

Motorcycle Service Department

GROUP INDEX

GENERAL INFORMATION	1
PERIODIC MAINTENANCE AND TUNE-UP PROCEDURES	2
ENGINE	3
FUEL AND LUBRICATION SYSTEM	4
COOLING SYSTEM	5
ELECTRICAL SYSTEM	6
CHASSIS	7
SERVICING INFORMATION	8
EMISSION CONTROL INFORMATION	9
GSF400N ('92-MODEL)	10
GSF400P ('93-MODEL)	11

VIEW OF SUZUKI GSF400/BANDIT



LEFT SIDE



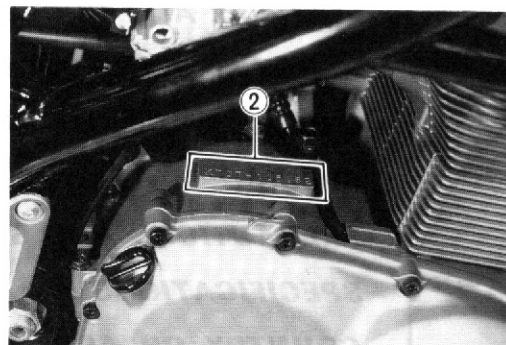
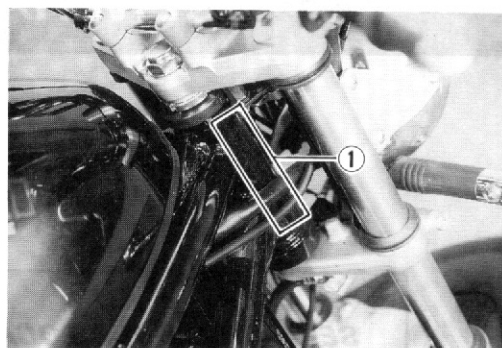
RIGHT SIDE

CONTENTS

SERIAL NUMBER LOCATION	1- 1
FUEL, OIL AND COOLANT RECOMMENDATION	1- 1
BREAK-IN PROCEDURES	1- 3
CYLINDER IDENTIFICATION	1- 3
SPECIAL MATERIALS	1- 4
PRECAUTIONS AND GENERAL INSTRUCTIONS	1- 7
SPECIFICATIONS	1- 9
COUNTRY OR AREA	1-11
EXTERIOR PARTS REMOVAL	1-12

SERIAL NUMBER LOCATION

The frame serial number or V.I.N. (Vehicle Identification Number) ① is stamped on the steering head pipe. The engine serial number ② is located on the right side of the crankcase. These numbers are required especially for registering the machine and ordering spare parts.



FUEL, OIL AND COOLANT RECOMMENDATION

FUEL (For U.S.A model)

1. Use only unleaded gasoline of at least 87 pump octane by the $\frac{R+M}{2}$ method or 91 octane or higher rated by the Research method.
2. Suzuki recommends that customers use alcohol-free, unleaded gasoline whenever possible.
3. Use of blended gasoline containing MTBE (Methyl Tertiary Butyl Ether) is permitted.
4. Use of blended gasoline/alcohol fuel is permitted, provided that the fuel contains not more than 10% ethanol. Gasoline/alcohol fuel may contain up to 5% methanol if appropriate cosolvents and corrosion inhibitors are present in it.
5. If the performance of the vehicle is unsatisfactory while using blended gasoline/alcohol fuel, you should switch to alcohol-free unleaded gasoline.
6. Failure to follow these guideline could possibly void applicable warranty coverage. Check with your fuel supplier to make sure that the fuel you intend to use meets the requirements listed above.

FUEL (For Canadian model)

Use only unleaded gasoline of at least 87 pump octane by the $\frac{R+M}{2}$ method or 91 octane or higher rated by the Research method.

FUEL (For the other models)

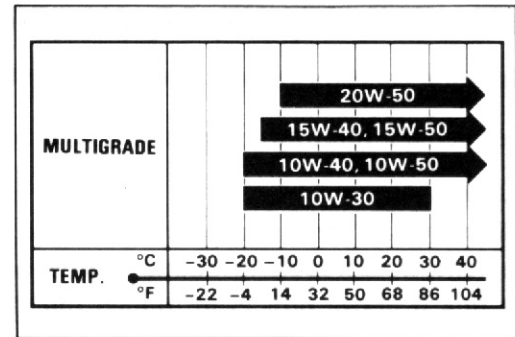
Gasoline used should be graded 85 – 95 octane by the Research method or higher. An unleaded gasoline is recommended.

ENGINE OIL (For U.S.A. model)

Suzuki recommends the use of SUZUKI PERFORMANCE 4 MOTOR OIL or an oil which is rated SE or SF under the API (American Petroleum Institute) classification system. The viscosity rating is SAE 10W/40. If an SAE 10W/40 motor oil is not available, select an alternate according to the following chart.

ENGINE OIL (For the other models)

Make sure that the engine oil you use comes under API classification of SE or SF and that its viscosity rating is SAE 10W/40. If an SAE 10W/40 motor oil is not available, select an alternate according to the following chart.



BRAKE FLUID

Specification and classification: DOT4

WARNING:

- * Since the brake system of this motorcycle is filled with a glycol-based brake fluid by the manufacturer, do not use or mix different types of fluid such as silicone-based and petroleum-based fluid for refilling the system, otherwise serious damage will result.
- * Do not use any brake fluid taken from old or used or unsealed containers.
- * Never reuse brake fluid left over from a previous servicing, which has been stored for a long period.

FRONT FORK OIL

Use fork oil #10.

COOLANT

Use an anti-freeze/coolant compatible with an aluminum radiator, mixed with distilled water only.

WATER FOR MIXING

Use distilled water only. Water other than distilled water can corrode and clog the aluminum radiator.

ANTI-FREEZE/COOLANT

The coolant perform as a corrosion and rust inhabit as well as anti-freeze. Therefore, the coolant should be used at all times even though the atmospheric temperature in your area does not go down to freezing point.

Suzuki recommends the use of SUZUKI GOLDEN CRUISER 1200NA anti-freeze/coolant. If this is not available, use an equivalent which is compatible with an aluminum radiator.

LIQUID AMOUNT OF WATER/COOLANT

Solution capacity (total): 1900 ml (2.0/1.7 US/Imp qt)

For coolant mixture information, refer to cooling system section, page 5-4.

CAUTION:

Mixing of anti-freeze/coolant should be limited to 60%. Mixing beyond it would reduce its efficiency. If the anti-freeze/coolant mixing ratio is below 50%, rust inhabiting performance is greatly reduced. Be sure to mix it above 50% even though the atmospheric temperature does not go down to the freezing point.

BREAK-IN PROCEDURES

During manufacture only the best possible materials are used and all machined parts are finished to a very high standard but it is still necessary to allow the moving parts to "BREAK-IN" before subjecting the engine to maximum stresses. The future performance and reliability of the engine depends on the care and restraint exercise during its early life. The general rules are as follows.

- Keep to these break-in engine speed limits:

Initial 800 km (500 miles) : Below 5000 r/min

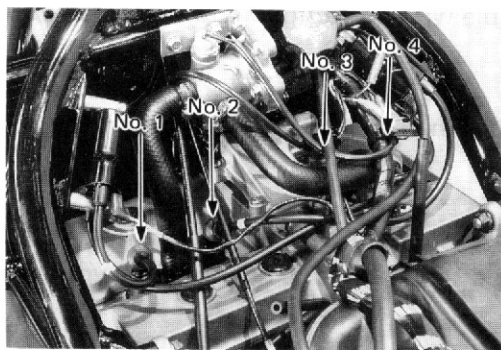
Up to 1600 km (1000 miles) : Below 8000 r/min

Over 1600 km (1000 miles) : Below 14000 r/min

- Upon reaching an odometer reading of 1600 km (1000 miles) you can subject the motorcycle to full throttle operation. However, do not exceed 14000 r/min at any time.







CYLINDER IDENTIFICATION

The four cylinders of this engine are identified as No. 1, No. 2, No. 3 and No. 4 cylinder, as counted from left to right (as viewed by the rider on the seat).



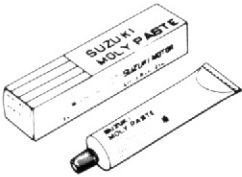
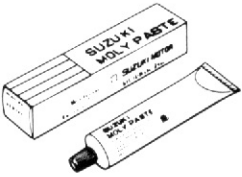

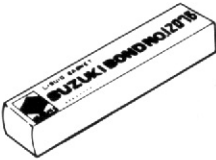














SPECIAL MATERIALS

The materials listed below are needed for maintenance work on the GSF400/BANDIT, and should be kept on hand for ready use. They supplement such standard materials as cleaning fluids, lubricants, emery cloth and the like. How to use them and where to use them are described in the text of this manual.

MATERIAL		PART	PAGE
For U.S.A. model	For other models		
 <p>SUZUKI BRAKE FLUID DOT3 & DOT4 99000-23110</p>	 <p>SUZUKI BRAKE FLUID DOT3 & DOT4 99000-23110</p>	<ul style="list-style-type: none"> • Brakes 	2-13 7- 8 7-10 7-23 7-26
 <p>SUZUKI GOLDEN CRUISER 1200NA 99000-99032-10X</p>	 <p>SUZUKI GOLDEN CRUISER 1200NA 99000-99032-10X</p>	<ul style="list-style-type: none"> • Coolant 	2-9 5-4
 <p>SUZUKI SUPER GREASE "A" 99000-25030</p>	 <p>SUZUKI SUPER GREASE "A" 99000-25010</p>	<ul style="list-style-type: none"> • Brake pedal pivot • Footrest pivot • Gearshift lever pivot • Side-stand pivot and spring hook • Center stand pivot and spring hook • Driveshaft oil seal and counter-shaft oil seal • Starter motor O-ring • Water pump O-ring • Starter motor oil seal • Wheel bearing • Speedometer gear box dust seal • Steering stem bearing and dust seal • Swingarm spacer, bearing and dust seal • Cushion lever/rod bearing • Water pump oil seal • Sprocket mounting drum bearing and oil seal 	2-2 2-2 2-2 2-2, 8-21 2-2, 8-21 3-42 3-54 3-55 6-12 7-3, 30 7-4 7-18 7-45 7-45 5-13 7-31

1-5 GENERAL INFORMATION

MATERIAL		PART	PAGE
For U.S.A. model	For other models		
 <p>SUZUKI SILICONE GREASE 99000-25100</p>	 <p>SUZUKI SILICONE GREASE 99000-25100</p>	<ul style="list-style-type: none"> ● Brake caliper axle 	7-6
 <p>SUZUKI MOLY PASTE 99000-25140</p>	 <p>SUZUKI MOLY PASTE 99000-25140</p>	<ul style="list-style-type: none"> ● Valve stem ● Conrod big end bearing ● Countershaft and driveshaft ● Piston pin ● Crankshaft journal bearing ● Camshaft journal and cam face ● Rocker arm and shaft ● Starter motor armature end 	<p>3-26 3-35 3-42 3-56 3-46 3-58 3-20 6-12</p>
 <p>SUZUKI BOND NO. 1207B 99104-31140</p>	 <p>SUZUKI BOND NO. 1207B 99000-31140</p>	<ul style="list-style-type: none"> ● Oil pressure switch ● Mating surface of upper and lower crankcases ● Mating surface of clutch cover ● Mating surface of starter clutch cover ● Camshaft end cap ● Breather cover ● Water pump mechanical seal 	<p>3-49 3-47 3-53 3-61 3-61 3-62 5-13</p>
 <p>THREAD LOCK SUPER "1303" 99000-32030</p>	 <p>THREAD LOCK SUPER "1303" 99000-32030</p>	<ul style="list-style-type: none"> ● Cam sprocket bolt ● Cam chain guide screw ● 2nd drive gear ● Breather cover 	<p>3-29 3-30 3-42 3-62</p>
 <p>THREAD LOCK "1342" 99000-32050</p>	 <p>THREAD LOCK "1342" 99000-32050</p>	<ul style="list-style-type: none"> ● Starter motor housing bolt ● Front fork damper rod bolt ● Countershaft bearing retainer screw ● Oil gallery plug retainer screw ● Gearshift cam guide screw and pawl lifter screw ● Carburetor set plate screw 	<p>6-12 7-14 3-47 3-47 3-48 4-11</p>

MATERIAL		PART	PAGE
For U.S.A. model	For other models		
 <p>THREAD LOCK SUPER "1333B" 99000-32020</p>	 <p>THREAD LOCK SUPER "1322" 99000-32110</p>	<ul style="list-style-type: none"> ● Generator stator mounting screw and lead wire clamp screw ● Signal generator coil mounting screw and lead wire guide screw 	<p>3-52 6-7</p>
 <p>THREAD LOCK SUPER "1360" 99000-32130</p>	 <p>THREAD LOCK SUPER "1360" 99000-32130</p>	<ul style="list-style-type: none"> ● Brake disc mounting bolt 	<p>7-4 7-32</p>
 <p>THREAD LOCK SUPER "1303" 99000-32030</p>	 <p>THREAD LOCK SUPER "1305" 99000-32100</p>	<ul style="list-style-type: none"> ● Generator rotor bolt ● Starter clutch bolt 	<p>3-52 3-53</p>
 <p>SUZUKI FORK OIL # 10 99000-99044-10G</p>	 <p>SUZUKI FORK OIL # 10 99000-99044-10G</p>	<ul style="list-style-type: none"> ● Front fork 	<p>7-15</p>

PRECAUTIONS AND GENERAL INSTRUCTIONS

Observe the following items without fail when servicing, disassembling and reassembling motorcycles.

- Do not run engine indoors with little or no ventilation.
- Be sure to replace packings, gaskets, circlips, O-rings and cotter pins with new ones.

CAUTION:

- * **Never reuse a circlip. After a circlip has been removed from a shaft, it should be discarded and a new circlip must be installed.**
- * **When installing a new circlip, care must be taken not to expand the end gap larger than required to slip the circlip over the shaft.**
- * **After installing a circlip, always insure that it is completely seated in its groove and securely fitted.**
- Tighten cylinder head and case bolts and nuts, beginning with larger diameter and ending with smaller diameter, from inside to out-side diagonally, to the specified tightening torque.
- Use special tools where specified.
- Use genuine parts and recommended oils.
- When 2 or more persons work together, pay attention to the safety of each other.
- After the reassembly, check parts for tightness and operation.
- Treat gasoline, which is extremely flammable and highly explosive, with greatest care. Never use gasoline as cleaning solvent.

Warning, Caution and Note are included in this manual occasionally, describing the following contents.

WARNING The personal safety of the rider or bystanders may be involved. Disregarding this information could result in personal injury.

CAUTION These instructions point out special service procedures or precautions that must be followed to avoid damaging the machine.

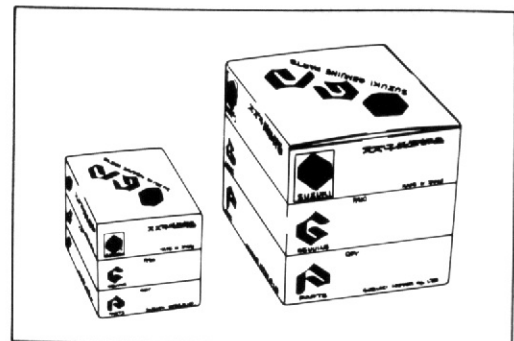
NOTE This provides special information to make maintenance easier or important instructions clearer.

REPLACEMENT PARTS

When you replace any parts, use only genuine SUZUKI replacement parts, or their equivalent. Genuine SUZUKI parts are high quality parts which are designed and built specifically for SUZUKI vehicles.

CAUTION:

Use of replacement parts which are not equivalent in quality to genuine SUZUKI parts can lead to performance problems and damage.



ASBESTOS INFORMATION

Note the following when handling a supply part with this WARNING LABEL, or any part in the parts list which contains asbestos.

- Operate if possible out of doors in a well ventilated place.
- Preferably use hand tools or low speed tools equipped, if necessary, with an appropriate dust extractor facility. If high speed tools are used, they should always be so equipped.
- If possible, dampen before cutting or drilling.
- Dampen dust and place it in a properly closed receptacle and dispose of it safely.

Any domestic asbestos product to which the above does not apply, but which is likely to release fibres during use should be replaced by new one when worn.



1.	Breather cover gasket
2.	Clutch cover gasket
3.	Starter gear cover gasket
4.	Oil pan gasket
5.	Cam chain tension adjuster gasket
6.	Exhaust pipe gasket

NOTE:

Refer to the parts catalogue for details.

SPECIFICATIONS

DIMENSIONS AND DRY MASS

Overall length	2130 mm (83.9 in) . . . E22 2090 mm (82.3 in) . . . Others
Overall width	760 mm (29.9 in) . . . E03, 28, 33 730 mm (28.7 in) . . . Others
Overall height	1070 mm (42.1 in) . . . E03, 28, 33 1060 mm (41.7 in) . . . Others
Wheelbase	1430 mm (56.3 in)
Ground clearance	155 mm (6.1 in)
Seat height	790 mm (31.1 in)
Dry mass	168 kg (370 lbs) . . . E22 165 kg (364 lbs) . . . Others

ENGINE

Type	Four-stroke, water-cooled, DOHC, TSCC
Valve clearance	IN : 0.10 – 0.15 mm (0.004 – 0.006 in) EX: 0.15 – 0.20 mm (0.006 – 0.008 in)
Number of cylinders	4
Bore	56.0 mm (2.20 in)
Stroke	40.4 mm (1.59 in)
Piston displacement	398 cm ³ (24.28 cu. in)
Compression ratio	11.8 : 1
Carburetor	MIKUNI BST33SS, four MIKUNI BST32SS, four . . . U.S.A. model only
Air cleaner	Polyurethane foam element
Starter system	Electric starter motor
Lubrication system	Wet sump

TRANSMISSION

Clutch	Wet multi-plate type
Transmission	6-speed constant mesh
Gearshift pattern	1-down, 5-up
Primary reduction ratio	1.954 (86/44)
Gear ratios, Low	3.363 (37/11)
2nd	2.307 (30/13)
3rd	1.750 (28/16)
4th	1.437 (23/16)
5th	1.250 (30/24)
Top	1.150 (23/20)
Final reduction ratio	3.357 (47/14)
Drive chain	DID 525V ₉ or RK 525SMOZ ₂ , 114 links

CHASSIS

Front suspension	Telescopic, coil spring, oil damped
Rear suspension	New-link suspension, coil spring, gas/oil damped, spring preload 7-way adjustable
Front suspension stroke	120 mm (4.7 in)
Rear wheel travel	120 mm (4.7 in)
Caster	64° 30'
Trail	100 mm (3.9 in)
Steering angle	30° (right & left)
Turning radius	3.2 m (10.5 ft)
Front brake	Disc brake
Rear brake	Disc brake
Front tire size	110/70-17 54H, tubeless
Rear tire size	150/70-17 69H, tubeless

ELECTRICAL

Ignition type	Fully transistorized
Ignition timing	15° B.T.D.C. below 1500 r/min
Spark plug	NGK CR8EK or NIPPON DENSO U24ETR
Battery	12V 28.8 kC (8Ah)/10HR
Generator	Three-phase A.C. generator
Fuse	25/15/10/10A
Headlight	12V 60/55W
Position light	12V 4W . . . except E03, 28, 33
Turn signal light	12V 21W
Tail/Brake light	12V 5/21W
License plate light	12V 5W
Speedometer light	12V 1.7W x 2 pcs
Tachometer light	12V 1.7W x 2 pcs
Neutral indicator light	12V 3W
High beam indicator light	12V 1.7W
Turn signal light indicator light	12V 3.4W
Oil pressure indicator light	12V 3.4W
Coolant temperature check light	12V 3.4W

CAPACITIES

Fuel tank, including reserve	14.5 L (3.8/3.2 US/Imp gal) . . . E33 only
	16.0 L (4.2/3.5 US/Imp gal) . . . Others
Reserve	3.5 L (0.9/0.8 US/Imp gal)
Engine oil, oil change	2300 ml (2.4/2.0 US/Imp qt)
with filter change	2800 ml (3.0/2.5 US/Imp qt)
overhaul	3200 ml (3.4/2.8 US/Imp qt)
Coolant (including reserve)	1900 ml (2.0/1.7 US/Imp qt)
Front fork oil (each leg)	494 ml (16.7/17.4 US/Imp oz) . . . E03, 28, 33
	495 ml (16.7/17.4 US/Imp oz) . . . Others

These specifications are subject to change without notice.

COUNTRY OR AREA

The series of symbols on the left stand for the countries and areas on the right.

SYMBOL	COUNTRY or AREA
E-02	England
E-03	U.S.A. (except California)
E-04	France
E-21	Belgium
E-22	West Germany
E-24	Australia
E-25	Netherlands
E-28	Canada
E-33	California (U.S.A.)
E-34	Italy

PERIODIC MAINTENANCE AND TUNE-UP PROCEDURES

CONTENTS

PERIODIC MAINTENANCE SCHEDULE.....	2- 1
PERIODIC MAINTENANCE CHART.....	2- 1
LUBRICATION POINTS.....	2- 2
MAINTENANCE AND TUNE-UP PROCEDURES.....	2- 3
BATTERY.....	2- 3
CYLINDER HEAD NUTS & EXHAUST PIPE BOLTS.....	2- 3
AIR CLEANER.....	2- 4
VALVE CLEARANCE.....	2- 5
SPARK PLUGS.....	2- 7
ENGINE OIL AND OIL FILTER.....	2- 8
FUEL LINE.....	2- 8
CARBURETORS.....	2- 9
COOLING SYSTEM.....	2- 9
CLUTCH.....	2-10
DRIVE CHAIN.....	2-11
BRAKES.....	2-13
TIRES.....	2-15
STEERING.....	2-16
FRONT FORKS.....	2-17
REAR SUSPENSION.....	2-17
CHASSIS BOLTS AND NUTS.....	2-18

PERIODIC MAINTENANCE SCHEDULE

IMPORTANT: The periodic maintenance intervals and service requirements have been established in accordance with EPA regulations. Following these instructions will ensure that the motorcycle will not exceed emission standards and it will also ensure the reliability and performance of the motorcycle.

NOTE:

More frequent servicing may be performed on motorcycles that are used under severe conditions however, it is not necessary for ensuring emission level compliance.

The chart below lists the recommended intervals for all the required periodic service work necessary to keep the motorcycle operating at peak performance and economy. Mileages are expressed in terms of kilometer, miles and time for your convenience.

PERIODIC MAINTENANCE CHART

INTERVALS: THIS INTERVAL SHOULD BE JUDGED BY ODOMETER READING OR MONTHS WHICHEVER COMES FIRST.	km	1000	6000	12000	18000	24000
	miles	600	4000	7500	11000	15000
	months	2	12	24	36	48
Battery		—	I	I	I	I
Cylinder head nuts & exhaust pipe bolts		T	T	T	T	T
Air cleaner element	Clean every 3000 km (2000 miles)					
Valve clearance		I	I	I	I	I
Spark plugs		—	I	R	I	R
Engine oil and oil filter		R	R	R	R	R
Fuel line (Vapor hose . . . California model only)		I	I	I	I	I
Carburetors (Engine idling speed)	Replace every four years					
Radiator hoses		I	—	I	—	I
Coolant	Replace every four years					
Clutch	Replace every two years					
Drive chain		I	I	I	I	I
Brake hoses	Clean and lubricate every 1000 km (600 miles)					
		I	I	I	I	I
	Replace every four years					
Brake fluid		I	I	I	I	I
	Replace every two years					
Brakes		I	I	I	I	I
Tires		I	I	I	I	I
Steering		I	I	I	I	I
Front forks		I	—	I	—	I
Rear suspension		I	—	I	—	I
Chassis bolts and nuts		T	T	T	T	T

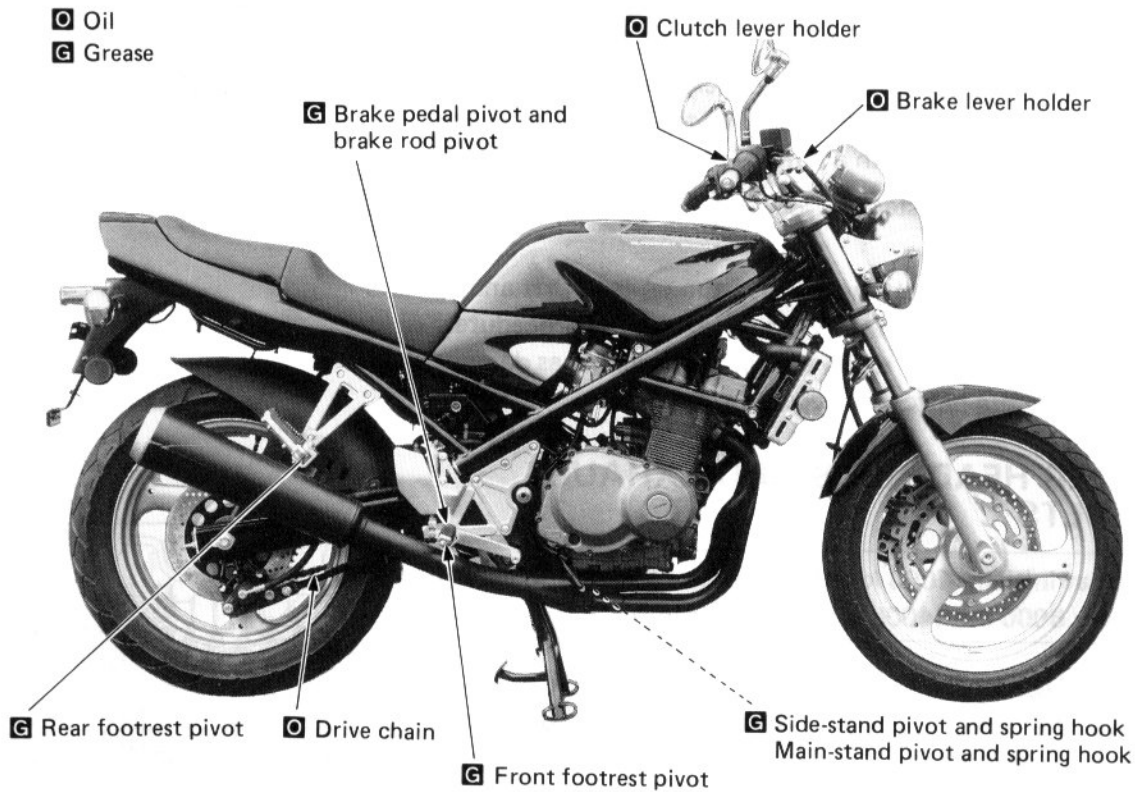
NOTE:

R = Replace, T = Tighten,

I = Inspect and adjust, clean, lubricate or replace as necessary

LUBRICATION POINTS

Proper lubrication is important for smooth operation and long life of each working part of the motorcycle. Major lubrication points are indicated below.



NOTE:

- * Before lubricating each part, clean off any rusty spots and wipe off any grease, oil, dirt or grime.
- * Lubricate exposed parts which are subject to rust, with oil or grease.

MAINTENANCE AND TUNE-UP PROCEDURES

This section describes the servicing procedures for each item of the Periodic Maintenance requirements.

BATTERY

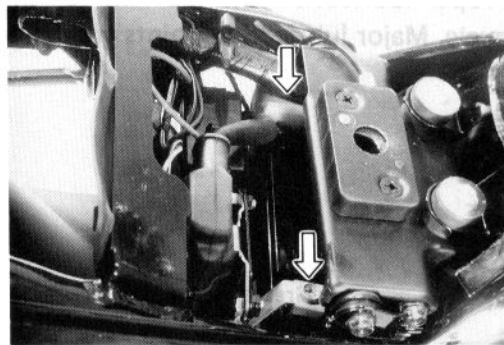
Inspect every 6000 km (4000 miles or 12 months).

- Remove the seat.
- Check the battery voltage with the pocket tester.
- If the tester reads under 12V, remove the battery from the machine and charge it with a battery charger.

09900-25002: Pocket tester

CAUTION:

- * When removing the battery, remove the \ominus lead first and \oplus lead last. To install the battery leads, reverse the procedure.
- * Never charge a battery while still in the machine as damage may result to the battery or regulator/rectifier.



CYLINDER HEAD NUTS AND EXHAUST PIPE BOLTS

Tighten at initially 1000 km (600 miles or 2 months) and every 6000 km (4000 miles or 12 months).

CYLINDER HEAD

- Remove the seat, air cleaner side covers and fuel tank. (Refer to pages 1-12 and 4-2.)
- Drain coolant. (Refer to page 2-10.)
- Remove the radiator. (Refer to page 5-5.)
- Disconnect the left and right water hoses from the cylinder head. (Refer to page 5-6.)
- Remove the thermostat case. (Refer to page 5-6.)
- Remove the left and right ignition coils. (Refer to page 2-5.)
- Remove the cylinder head cover. (Refer to page 3-10.)
- First loosen and retighten the nuts to the specified torque with a torque wrench sequentially in ascending numerical order with the engine cold.

Tightening torque

Cylinder head nut: 25 – 29 N·m

(2.5 – 2.9 kg-m, 18.0 – 21.0 lb-ft)

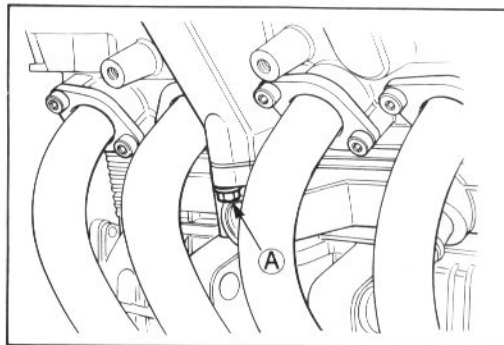
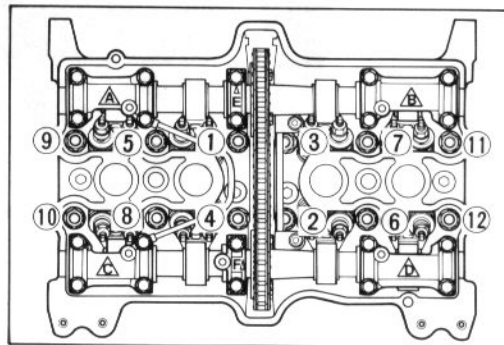
- After firmly tightening the 12 nuts, tighten the bolt (indicated as \textcircled{A}) to the torque value below:

Tightening torque

Cylinder head bolt \textcircled{A} : 8 – 12 N·m (0.8 – 1.2 kg-m, 6.0 – 8.5 lb-ft)

- When installing the cylinder head cover, apply SUZUKI BOND No. 1207B to the cam end caps. (Refer to page 3-61.)
- Tighten the head cover bolts to the specified torque.

Tightening torque: 8 – 12 N·m (0.8 – 1.2 kg-m, 6.0 – 8.5 lb-ft)



EXHAUST PIPE AND MUFFLER

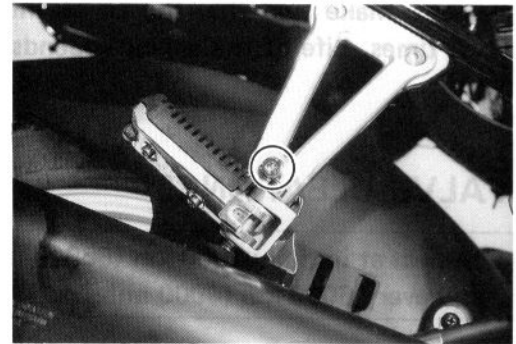
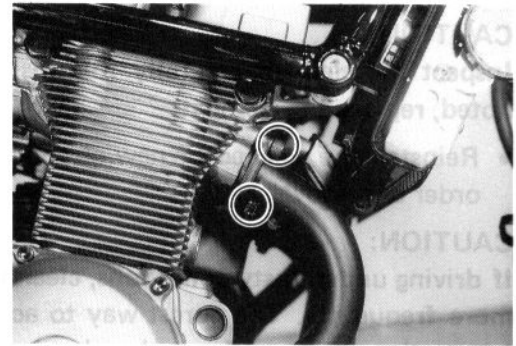
- Tighten the exhaust pipe clamp bolts and muffler mounting bolt to the specified torque with a torque wrench.

Tightening torque

Exhaust pipe bolt and

Muffler mounting bolt : 18 – 28 N·m

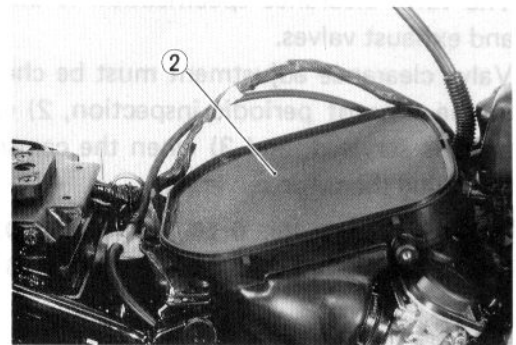
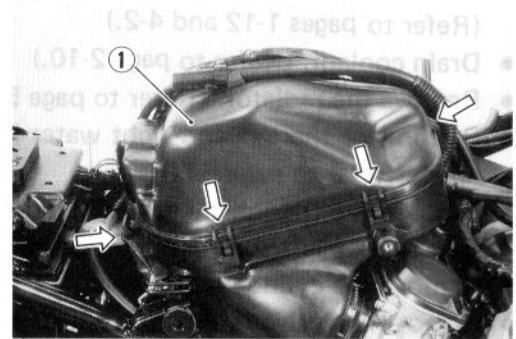
(1.8 – 2.8 kg-m, 13.0 – 20.0 lb-ft)



AIR CLEANER

Clean every 3000 km (2000 miles)

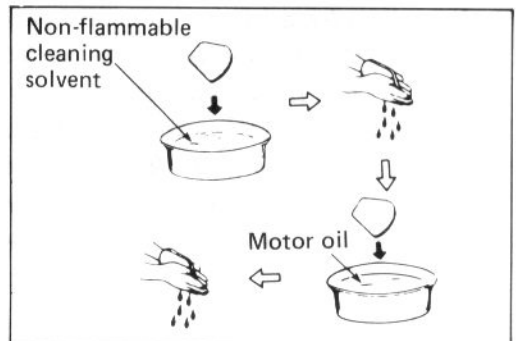
- Remove the seat, air cleaner side covers and fuel tank. (Refer to pages 1-12 and 4-2.)
- Remove the air cleaner cap ① by unhooking the 7 hooked parts.
- Remove the polyurethane foam element ②.



- Fill a washing pan of a proper size with non-flammable cleaning solvent. Immerse the element in the cleaning solvent and wash it clean.
- Squeeze the cleaning solvent out of the washed element by pressing it between the palms of both hands.
- Immerse the element in motor oil, and squeeze the oil out of the element leaving it slightly wet with oil.

NOTE:

Do not twist or wring the element because it will tear or the individual cells of the element will be damaged.



2-5 PERIODIC MAINTENANCE AND TUNE-UP PROCEDURES

CAUTION:

Inspect the element carefully for rips, etc. If any damage is noted, replace the element.

- Reinstall the cleaned or new cleaner element in the reverse order of removal.

CAUTION:

If driving under dusty conditions, clean the air cleaner element more frequently. The surest way to accelerate engine wear is to use the engine without the element or to use a ruptured element. Make sure that the air cleaner is in good condition at all times. Life of the engine depends largely on this component!

For U.S.A. and Canada models

NOTE:

When you clean the air element, drain water from the air cleaner drain hose end by removing the drain plug.

VALVE CLEARANCE

Inspect at initially 1000 km (600 miles or 2 months) and every 6000 km (4000 miles or 12 months).

- Remove the seat, air cleaner side covers and fuel tank. (Refer to pages 1-12 and 4-2.)
- Drain coolant. (Refer to page 2-10.)
- Remove the radiator. (Refer to page 5-5.)
- Disconnect the left and right water hoses from the cylinder head. (Refer to page 5-6.)
- Remove the thermostat case. (Refer to page 5-6.)
- Remove the left and right ignition coils ①.
- Remove the cylinder head cover.
- Remove the valve timing inspection plug on the clutch cover.

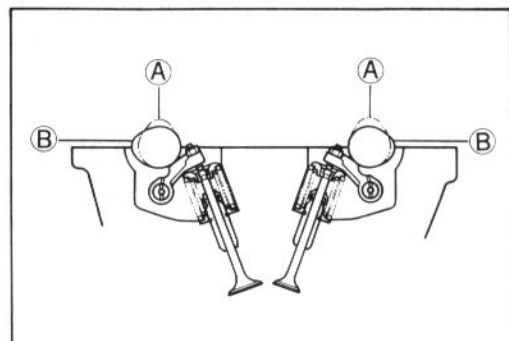
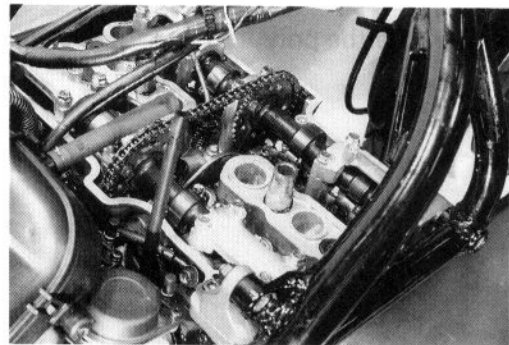
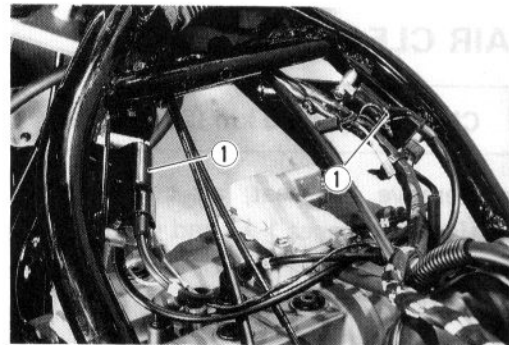
The valve clearance specification is different for both intake and exhaust valves.

Valve clearance adjustment must be checked and adjusted, 1) at the time of periodic inspection, 2) when the valve mechanism is serviced, and 3) when the camshafts are disturbed by removing them for servicing.

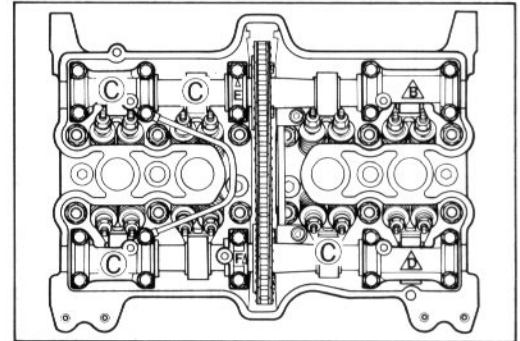
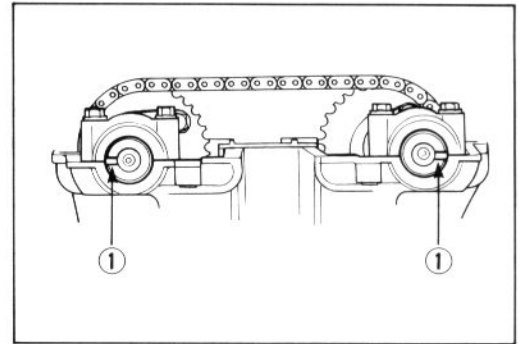
Valve clearance: IN. 0.10 – 0.15 mm (0.004 – 0.006 in)
(when cold) EX. 0.15 – 0.20 mm (0.006 – 0.008 in)

NOTE:

- * The cam must be at positions, A or B, in order to check the valve clearance, or to adjust valve clearance. Clearance readings should not be taken with the cam in any other position than these two positions.
- * The clearance specification is for COLD state.
- * To turn the crankshaft for clearance checking, be sure to use a 17-mm wrench, and rotate in the normal running direction. All spark plugs should be removed.



- Turn crankshaft to bring the notches ① in the right ends of both camshafts (Ex and In) to the positions shown. In this condition, read the valve clearance at the valves ③ (In and Ex of No. 1 cylinder, Ex of No. 2 and In of No. 3).



- Use a thickness gauge between the adjusting screw and the valve stem end. If the clearance is out of specification, bring it into the specified range by using the special tool.

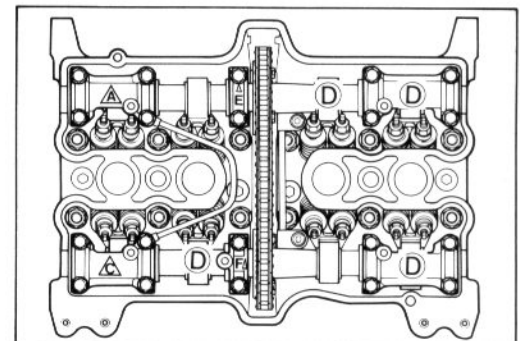
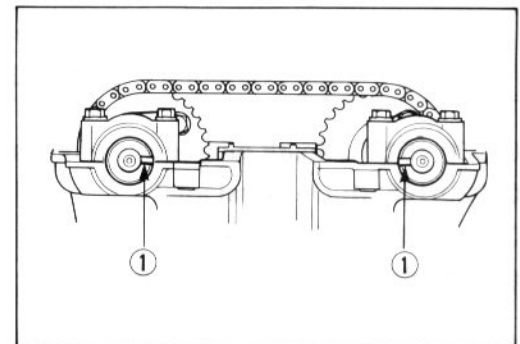
09900-20803: Thickness gauge

09917-14920: Valve adjust driver

CAUTION:

Both right and left valve clearances should be as closely set as possible.

- Turn the crankshaft 360° (one rotation) to bring the notches ① to the positions shown.
- Read the clearance at the remaining valves ④ and adjust the clearance if necessary.



Cam Position	Notch ① position	
	Intake Camshaft	Exhaust Camshaft
③	◐	◑
④	◑	◐

- When installing the cylinder head cover, apply SUZUKI BOND NO. 1207B to the cam end caps. (Refer to page 3-61.)
- Tighten the head cover bolts to the specified torque. (Refer to page 3-62.)
- Tighten the coolant drain plug securely.
- Pour the specified coolant up to the radiator inlet.

SPARK PLUGS

Inspect at 6000 km (4000 miles or 12 months), 18000 km (11000 miles or 36 months) and replace every 12000 km (7500 miles or 24 months).

- Remove the spark plugs with the spark plug wrench.

The plug gap is adjusted to 0.6 – 0.7 mm (0.02 – 0.03 in). The gap is correctly adjusted by using a thickness gauge. When carbon is deposited on the spark plug, remove the carbon by using a spark plug cleaning machine or by carefully using a tool with a pointed end. If the electrode is extremely worn or burnt, replace the plug. Also replace the plug if it has a broken insulator, damaged thread, etc.

NGK CR8EK as listed in the table should be used as the standard plug. However, the heat range of the plug should be selected to meet the requirements of speed, actual load, fuel etc. If the plugs need to be replaced, it is recommended that plugs having a heat range closest to the standard plug in the table be selected. Remove the plugs and inspect the insulators. Proper heat range would be indicated if all insulators are light brown in color. If they are baked white, they should be replaced by a cold type and if blackened by carbon, by a hot type.

Recommended spark plug

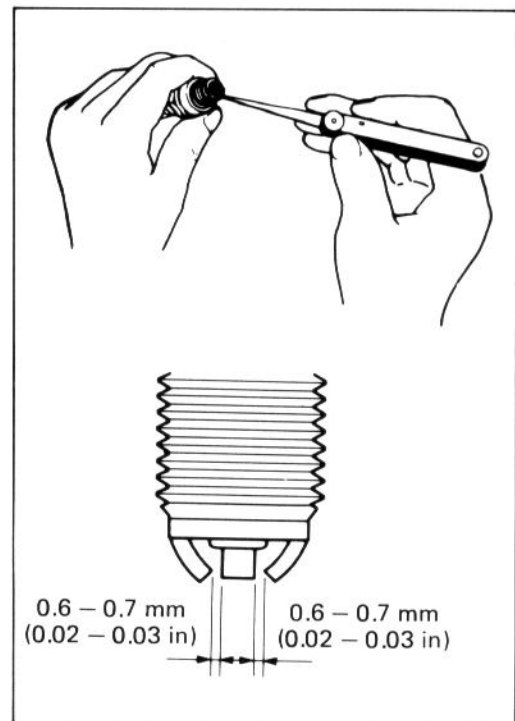
	Standard	Cold type	Hot type
NGK	CR8EK	CR9EK	CR7EK
ND	U24ETR	U27ETR	U22ETR

09930-10120: Spark plug socket wrench set

09930-14530: Universal joint

09914-24510: T-handle

09900-20803: Thickness gauge



CAUTION:

Confirm the thread size and reach when replacing the plug. If the reach is too short, carbon will be deposited on the screw portion of the plug hole and engine damage may result.

NOTE:

"R" type spark plug is installed for some specifications. "R" type spark plug has a resistor located at the center electrode to prevent radio noise.

ENGINE OIL AND OIL FILTER

Replace at initially 1000 km (600 miles or 2 months) and every 6000 km (4000 miles or 12 months).

Oil should be changed while the engine is hot. Oil filter replacement at the above intervals should be done together with engine oil change.

- Keep the motorcycle upright.
- Place an oil pan below the engine and drain oil by removing the drain plug ① and filler cap ②.
- Disconnect the oil pressure switch lead.
- Remove the oil filter cap ③ by removing the three nuts.
- Replace the oil filter with new one.

NOTE:

Be sure to take care of O-ring ④ to prevent any damage and be sure that filter spring ⑤ is properly in place.

- Apply grease lightly to the O-ring ④ of the oil filter cap ③ before installation.
- Fit the drain plug ① securely, and pour fresh oil through the oil filler. The engine will hold about 2.8 L (3.0 US qt) of oil. Use an API classification of SE or SF oil with SAE 10W/40 viscosity.
- Install the filler cap ②.
- Start up the engine and allow it to run for several minutes at idling speed.
- Turn off the engine and wait about one minute, then check the oil level through the inspection window ⑥. If the level is below the lower line, add oil to the upper line.

NECESSARY AMOUNT OF ENGINE OIL

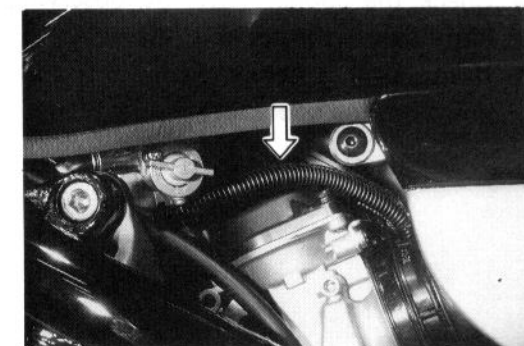
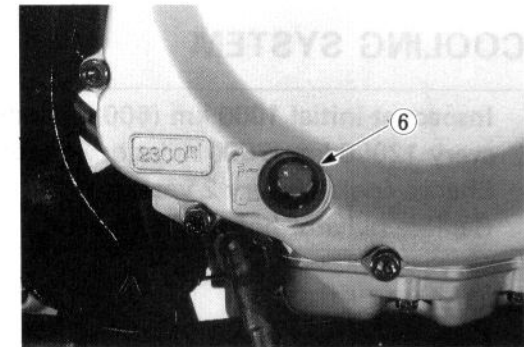
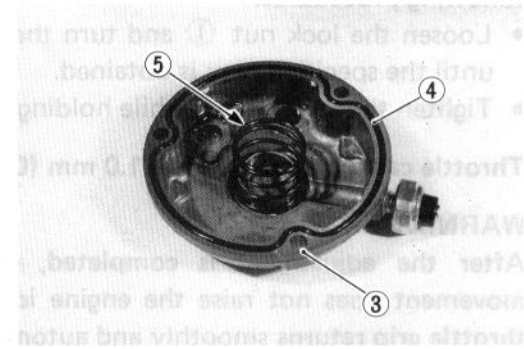
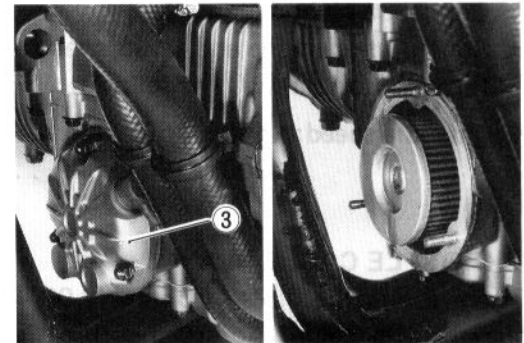
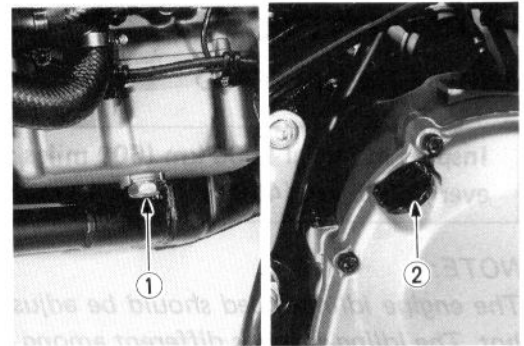
Oil change	2.3 L (2.4/2.0 US/Imp qt)
Filter change	2.8 L (3.0/2.5 US/Imp qt)
Overhaul engine	3.2 L (3.4/2.8 US/Imp qt)

FUEL LINE

Inspect at initially 1000 km (600 miles or 2 months) and every 6000 km (4000 miles or 12 months).
Replace every 4 years.

Inspect the fuel line for damage and fuel leakage. If any defects are found, the fuel line must be replaced. (Refer to page 8-19.)

VAPOR HOSE CALIFORNIA MODEL ONLY



CARBURETORS

ENGINE IDLING SPEED

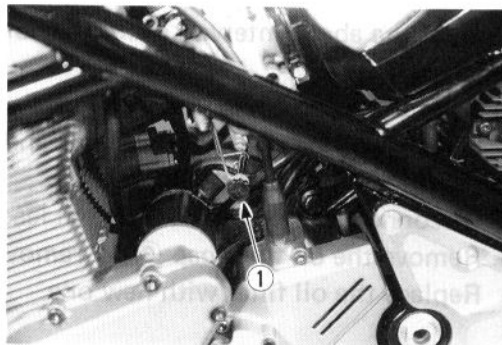
Inspect at initial 1000 km (600 miles or 2 months) and every 6000 km (4000 miles or 12 months).

NOTE:

The engine idling speed should be adjusted when the engine is hot. The idling speed is different among the countries.

- Connect a tachometer.
- Start up the engine and set its speed at idle speed by turning throttle stop screw ① as follows.

Engine idle speed: 1400 ± 50 r/min . . . E-03, 22 and 33
1300 ± 100 r/min . . . The others

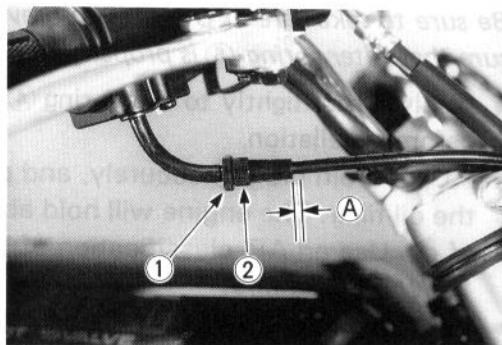


THROTTLE CABLE PLAY

There should be 0.5 – 1.0 mm (0.02 – 0.04 in) play **A** on the throttle cable. Adjust the throttle cable play with the following procedures.

- Loosen the lock nut ① and turn the adjuster ② in or out until the specified play is obtained.
- Tighten the lock nut ① while holding the adjuster.

Throttle cable play **A** : 0.5 – 1.0 mm (0.02 – 0.04 in)



WARNING:

After the adjustment is completed, check that handlebar movement does not raise the engine idle speed and that the throttle grip returns smoothly and automatically.

COOLING SYSTEM

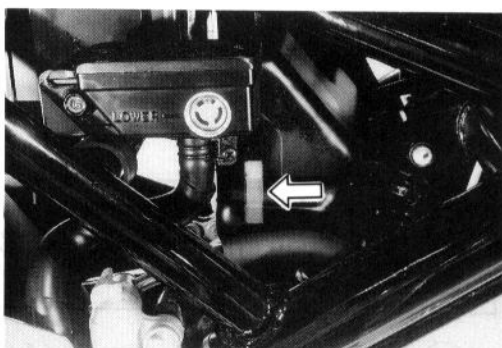
Inspect at initial 1000 km (600 miles or 2 months) and every 12000 km (7500 miles or 24 months).

Change coolant every 2 years.

Replace radiator hoses every 4 years.

COOLANT LEVEL

- Keep the motorcycle upright.
- Check the coolant level by observing the upper and lower limit line on the coolant reservoir.
- If the level is below mark "F", add coolant to the upper line from the coolant reservoir filler.



COOLANT CHANGE

- Remove the seat, air cleaner covers and fuel tank. (Refer to pages 1-12 and 4-2.)
- Remove the radiator cap ① and drain plug ②, and drain coolant.

WARNING:

- * Do not open the radiator cap when the engine is hot, as you may be injured by escaping hot liquid or vapor.
- * Coolant may be harmful if swallowed or if it comes in contact with skin or eyes. If coolant gets into the eyes or in contact with the skin, flush thoroughly with plenty of water. If swallowed, induce vomiting and call physician immediately!

- Flush the radiator with fresh water if necessary.
- Tighten the drain plug ② securely.
- Pour the specified coolant up to the radiator inlet.

Tightening torque

Coolant drain plug: 10 – 12 N·m
(1.0 – 1.2 kg·m, 7.0 – 8.5 lb·ft)

NOTE:

For coolant information, refer to page 5-4.

- Close the radiator cap ① securely.
- After warming up and cooling down the engine, add the specified coolant up to the coolant reservoir.

CAUTION:

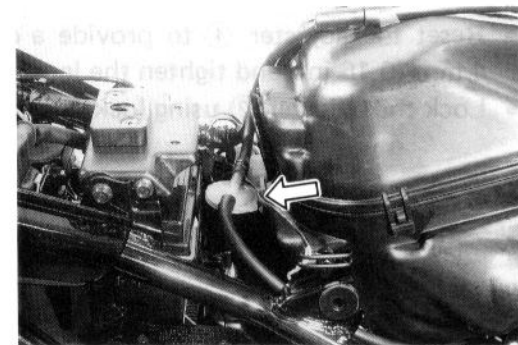
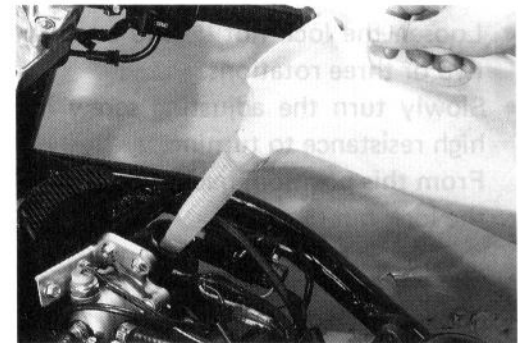
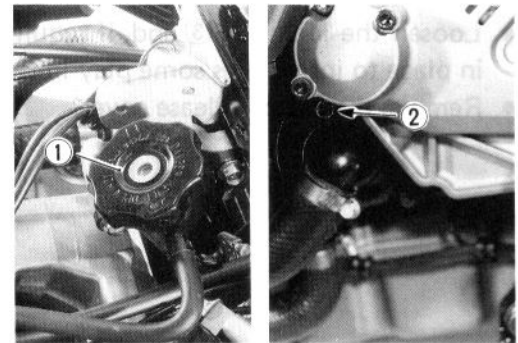
Repeat above procedure several times and make sure that the radiator is filled with coolant up to the coolant reservoir.

Coolant capacity: 1900 ml (2.0/1.7 US/Imp qt)

CLUTCH

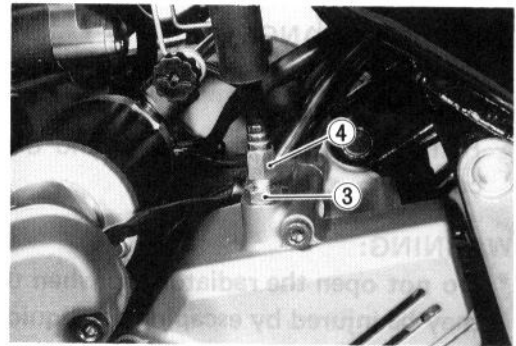
Inspect at initial 1000 km (600 miles or 2 months) and every 6000 km (4000 miles or 12 months).

- Loosen the lock nut ① and turn in the adjuster ② all the way into the clutch lever holder.

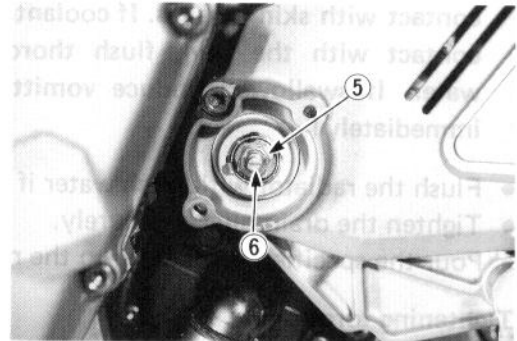


2-11 PERIODIC MAINTENANCE AND TUNE-UP PROCEDURES

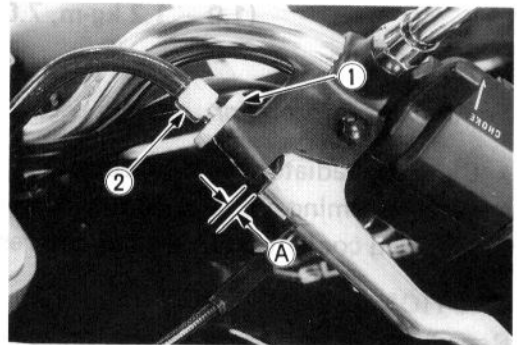
- Loosen the lock nut ③ and, if required, turn the adjuster ④ in place to introduces some play in the clutch lever.
- Remove the clutch release cover.



- Loosen the lock nut ⑤ and back the adjusting screw ⑥ out two or three rotations.
- Slowly turn the adjusting screw in until it begins to meet high resistance to turning. From this position, back it out 1/4 – 1/2 rotation and secure the lock nut ⑤.



- Reset the adjuster ④ to provide a clutch lever play (A) of 4 mm (0.16 in), and tighten the lock nut ③.
- Lock the adjuster ② using lock nut ①.



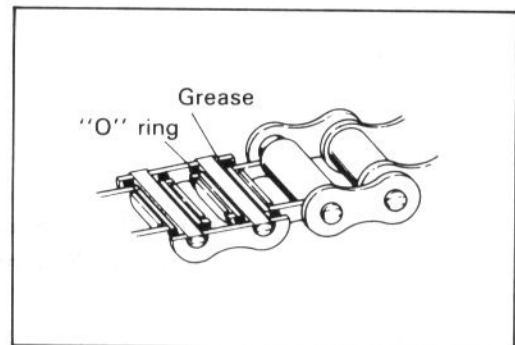
DRIVE CHAIN

Inspect at initially 1000 km (600 miles or 2 months) and every 6000 km (4000 miles or 12 months).
Clean and lubricate every 1000 km (600 miles).

Visually check the drive chain for the listed below possible defects. (Support the motorcycle by center stand, and turn the rear wheel slowly by hand with the transmission shifted to Neutral.)

- | | |
|---------------------------|-----------------------------|
| * Loose pins | * Excessive wear |
| * Damaged rollers | * Improper chain adjustment |
| * Dry or rusted links | * Missing O-ring seals |
| * Kinked or binding links | |

If any defects are found, the drive chain must be replaced.



CHECKING

- Remove the cotter pin. (For E-03, 28 and 33 models.)
- Loosen the axle nut ①.
- Tense the drive chain fully by tightening the chain adjusting nuts ②, left and right.

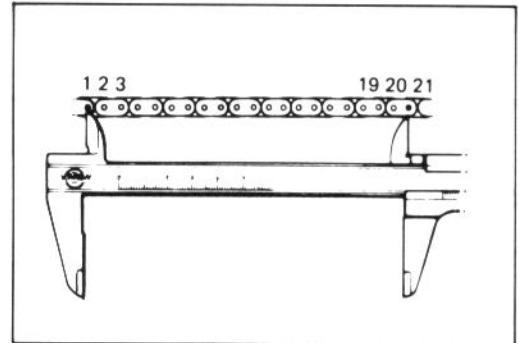
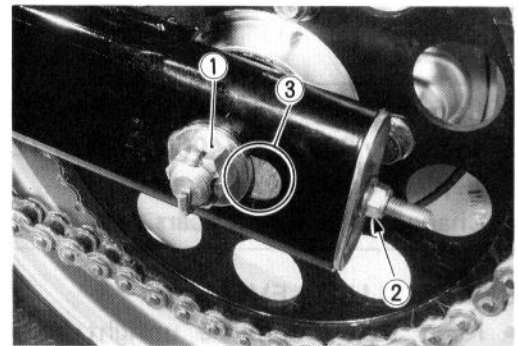
E-03 : U.S.A.

E-28 : Canada

E-33 : California (U.S.A.)

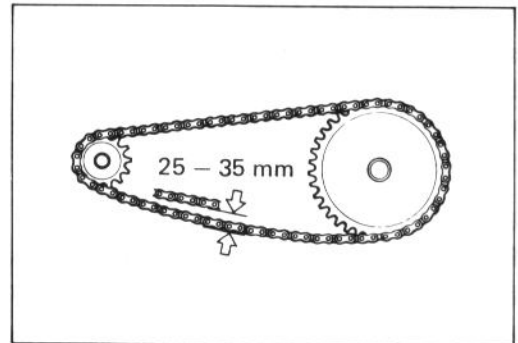
- Count out 21 pins (20 pitches) on the chain and measure the distance between the two points. If the distance exceeds following limit, the chain must be replaced.

Service Limit: 319.4 mm (12.57 in)



ADJUSTING

- Loosen or tighten the chain adjusting nuts ② until the chain has 25 – 35 mm (1.0 – 1.4 in) of slack at the middle between engine and rear sprockets. The mark ③ on both chain adjusters must be at the same position on the scale to ensure that the front and rear wheels are correctly aligned. Place on side stand for accurate adjustment.
- After adjusting the drive chain slack, tighten the axle nut ① securely.
- Tighten the chain adjusting nuts securely.



CLEANING AND LUBRICATING

- Wash the chain with kerosene. If the chain tends to rust faster, the intervals must be shortened.

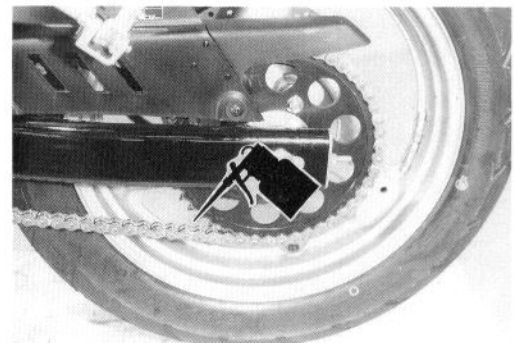
CAUTION:

Do not use trichlene, gasoline or any similar fluids. These fluids have too great a dissolving power for this chain and, what is more important, can damage the "O" rings (or seals) confining the grease in the bush to pin clearance. Remember, high durability comes from the presence of grease in that clearance.

- After washing and drying the chain, oil it with a heavy-weight motor oil.

CAUTION:

- * Do not use any oil sold commercially as "drive chain oil". Such oil can damage the "O" rings (or seals).
- * The standard drive chain is D.I.D. 525V₉ – 114 links or RK525SMOZ₂ – 114 links. SUZUKI recommends that the above-mentioned standard drive chain be used for the replacement.



BRAKES

Inspect system at initial 1000 km (600 miles or 2 months) and every 6000 km (4000 miles or 12 months).
Replace hoses every 4 years.
Change fluid every 2 years.

BRAKE FLUID LEVEL

- Keep the motorcycle upright and place the handlebars straight.
- Check the brake fluid level by observing the lower limit lines on the brake fluid reservoirs.
- When the level is below the lower limit line, replenish with brake fluid that meets the following specification.

Specification and Classification : DOT4

99000-23110 : SUZUKI BRAKE FLUID DOT3 & DOT4

WARNING:

The brake system of this motorcycle is filled with a glycol-based brake fluid. Do not use or mix different types of fluid such as silicone-based and petroleum-based. Do not use any brake fluid taken from old, used or unsealed containers. Never reuse brake fluid left over from the last servicing or stored for long periods.

WARNING:

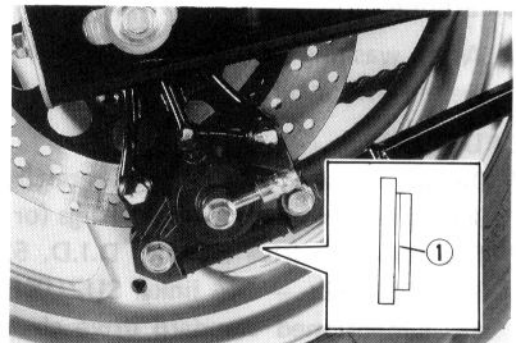
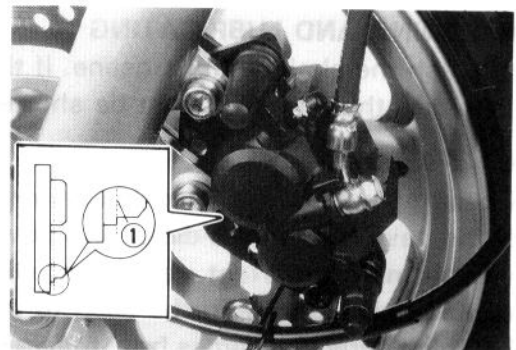
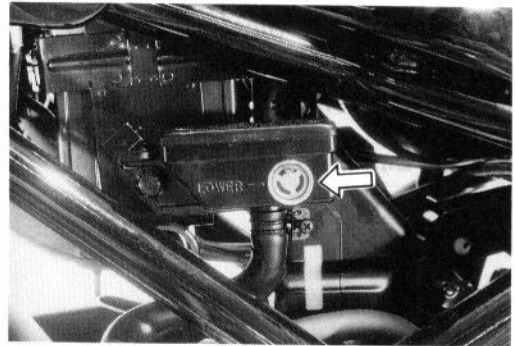
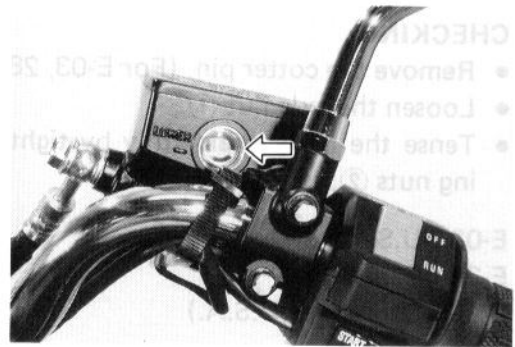
Brake fluid, if it leaks, will interfere with safe running and immediately discolor painted surfaces. Check the brake hoses and hose joints for cracks and oil leakage before riding.

BRAKE PADS

The extent of brake pad wear can be checked by observing the grooved limit line ① marked on the pad. When the wear exceeds the grooved limit line, replace the pads with new ones. (Refer to pages 7-6 and 7-21.)

CAUTION:

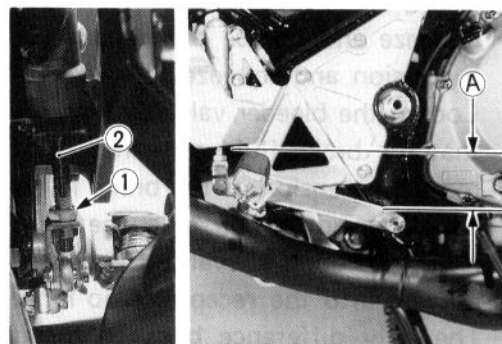
Replace the brake pad as a set, otherwise braking performance will be adversely affected.



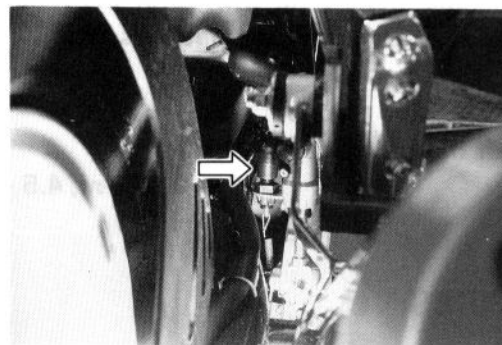
BRAKE PEDAL HEIGHT

- Loosen the lock nut ① and rotate the push rod ② to locate brake pedal 40 – 50 mm (1.6 – 2.0 in) below the top face of the footrest.
- Retighten the lock nut ① to secure the push rod ② in the proper position.

Brake pedal height **A** : 40 – 50 mm (1.6 – 2.0 in)

**BRAKE LIGHT SWITCHES**

Adjust both brake light switches, front and rear, so that the brake light will come on just before a pressure is felt when the brake lever is squeezed, or the brake pedal is depressed.

**AIR BLEEDING THE BRAKE FLUID CIRCUIT**

Air trapped in the fluid circuit acts like a cushion to absorb a large proportion of the pressure developed by the master cylinder and thus interferes with the full braking performance of the brake caliper. The presence of air is indicated by "sponginess" of the brake level/pedal and also by lack of braking force. Considering the danger to which such trapped air exposes the machine and rider, it is essential that, after remounting the brake and restoring the brake system to the normal condition, the brake fluid circuit be purged of air in the following manner:

- Fill up the master cylinder reservoir to the upper end of the inspection window. Replace the reservoir cap.
- Attach a pipe to the caliper bleeder valve, and insert the free end of the pipe into a receptacle.

2-15 PERIODIC MAINTENANCE AND TUNE-UP PROCEDURES

- Squeeze and release the brake lever several times in rapid succession and squeeze the level fully without releasing it. Loosen the bleeder valve by turning it a quarter of a turn so that the brake fluid runs into the receptacle; this will remove the tension of the brake lever causing it to touch the handlebar grip. Then, close the valve, pump and squeeze the lever, and open the valve. Repeat this process until the fluid flowing into the receptacle no longer contains air bubbles. The only difference between bleeding the front and rear brakes is that the rear master cylinder is actuated by a pedal.

NOTE:

Replenish the brake fluid in the reservoir as necessary while bleeding the brake system. Make sure that there is always some fluid visible in the reservoir.

- Close the bleeder valve, and disconnect the pipe. Fill the reservoir to the upper end of the inspection window.

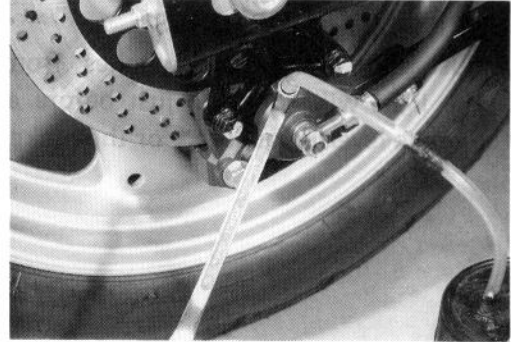
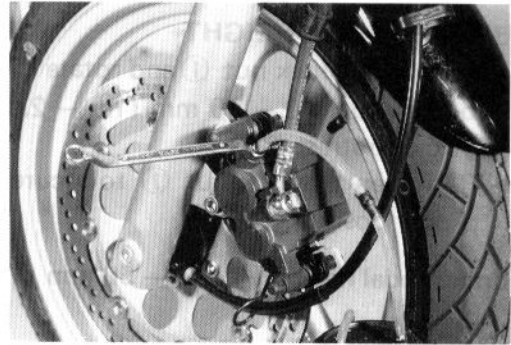
CAUTION:

Handle brake fluid with care: the fluid reacts chemically with paint, plastics, rubber materials etc.

Tightening torque

Air bleeder valve : 6 – 9 N·m

(0.6 – 0.9 kg-m, 4.5 – 6.5 lb-ft)



TIRES

Inspect at initially 1000 km (600 miles or 2 months) and every 6000 km (4000 miles or 12 months).

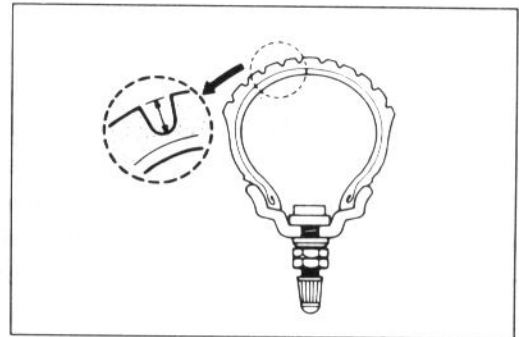
TIRE TREAD CONDITION

Operating the motorcycle with excessively worn tires will decrease riding stability and consequently invite a dangerous situation. It is highly recommended to replace a tire when the remaining depth of tire tread reaches the following specification.

Tire tread depth limit

Front : 1.6 mm (0.06 in)

Rear : 2.0 mm (0.08 in)



TIRE PRESSURE

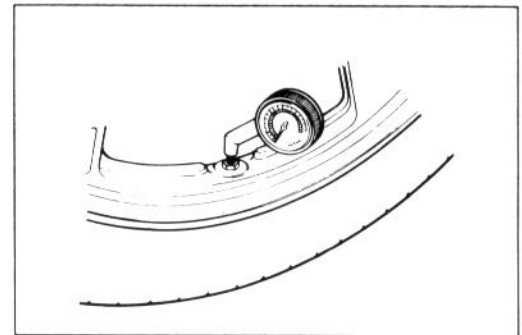
If the tire pressure is too high or too low, steering will be adversely affected and tire wear increased. Therefore, maintain the correct tire pressure for good roadability or shorter tire life will result.

Cold inflation tire pressure is as follows.

	FRONT			REAR		
	kg/cm ²	kPa	psi	kg/cm ²	kPa	psi
Solo riding	2.00	200	29	2.25	225	33
Dual riding	2.00	200	29	2.50	250	36

CAUTION:

The standard tire fitted on this motorcycle is 110/70-17 54H (DUNLOP K505FL) for front and 150/70-17 69H (DUNLOP K505J) for rear. The use of tires other than the those specified may cause instability. It is highly recommended to use a SUZUKI Genuine Tire.



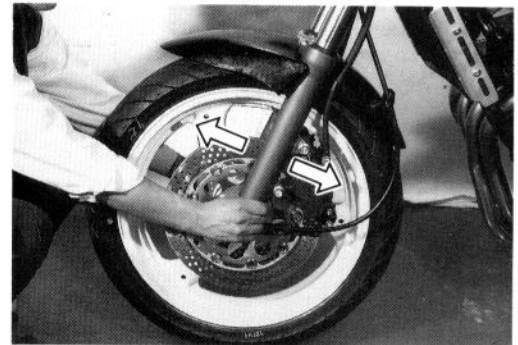
STEERING

Inspect at initially 1000 km (600 miles or 2 months) and every 6000 km (4000 miles or 12 months).

Taper roller type bearings are used on the steering system for better handling.

Steering should be adjusted properly for smooth turning of handlebars and safe running. Overtight steering prevents smooth turning of the handlebars and too loose steering will cause poor stability.

Check that there is no play in the front fork assembly by supporting the machine so that the front wheel is off the ground, with the wheel straight ahead, grasp the lower fork tubes near the axle and pull forward. If play is found, perform steering bearing adjustment as described in page 7-19 of this manual.



FRONT FORKS

Inspect at initially 1000 km (600 miles or 2 months) and every 12000 km (7500 miles or 24 months).

Inspect the front forks for oil leakage, scoring or scratches on the outer surface of the inner tubes. Replace any defective parts, if necessary.

(Refer to page 7-11.)

REAR SUSPENSION

Inspect at initially 1000 km (600 miles or 2 months) and every 12000 km (7500 miles or 24 months).

Inspect the rear shock absorber for oil leakage and check that there is no play in the swingarm assembly.

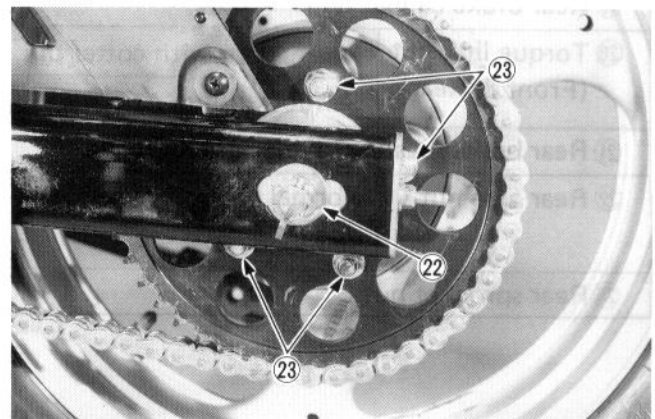
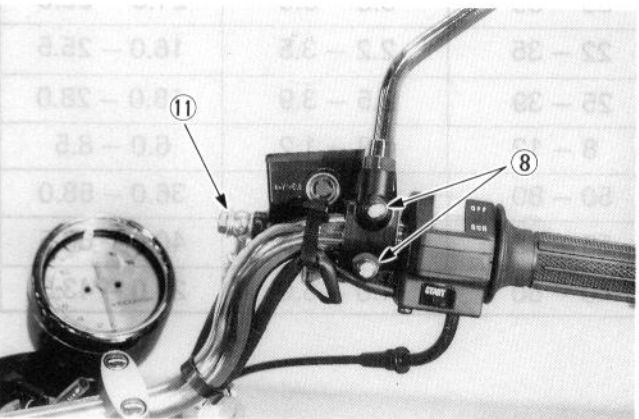
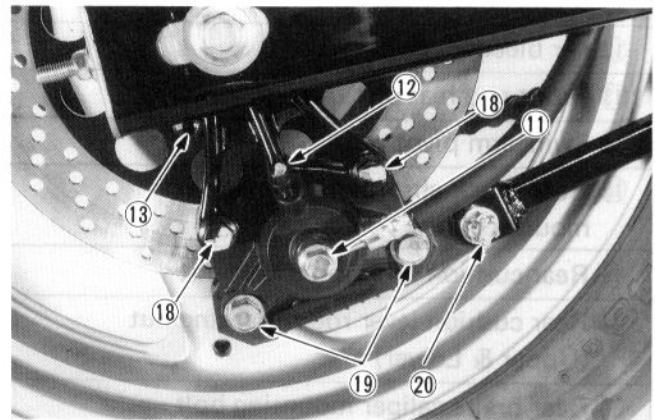
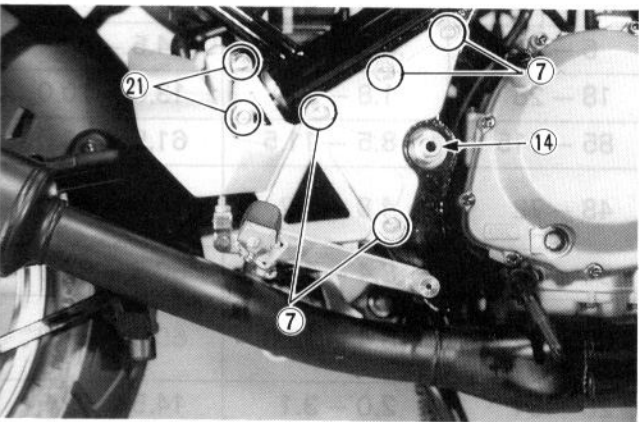
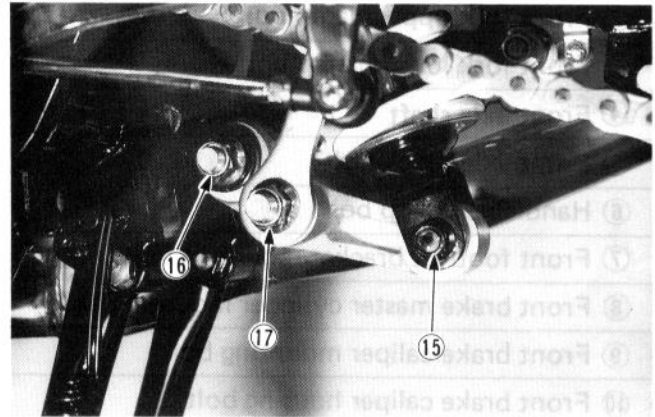
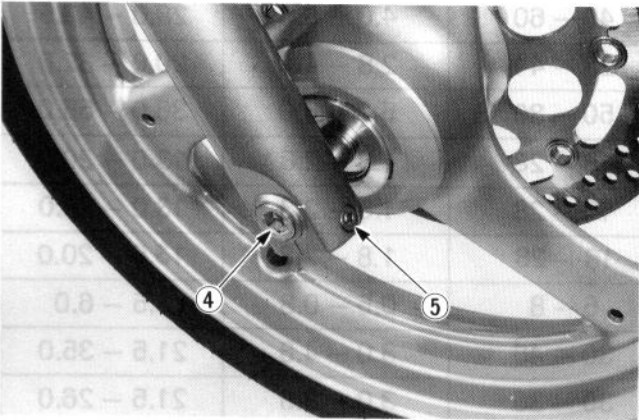
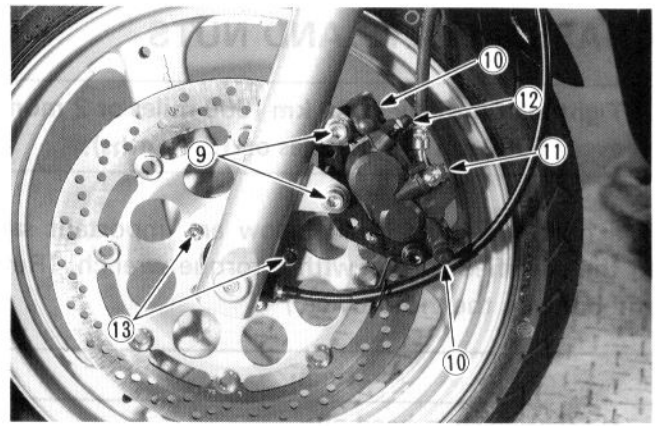
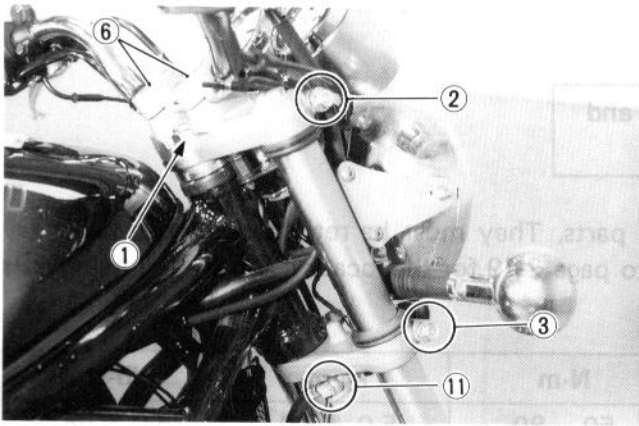
CHASSIS BOLTS AND NUTS

Tighten at initially 1000 km (600 miles or 2 months) and every 6000 km (4000 miles or 12 months).

The nuts and bolts listed below are important safety parts. They must be retightened when necessary to the specified torque with a torque wrench. (Refer to page 2-19 for the locations of the following nuts and bolts on the motorcycle.)

Item	N·m	kg·m	lb·ft
① Steering stem head nut	50 – 80	5.0 – 8.0	36.0 – 58.0
② Front fork upper clamp bolt	40 – 60	4.0 – 6.0	29.0 – 43.5
③ Front fork lower clamp bolt	28 – 44	2.8 – 4.4	20.0 – 32.0
④ Front axle shaft	50 – 80	5.0 – 8.0	36.0 – 58.0
⑤ Front axle pinch bolt	18 – 28	1.8 – 2.8	13.0 – 20.0
⑥ Handlebar clamp bolt	18 – 28	1.8 – 2.8	13.0 – 20.0
⑦ Front footrest bracket mounting bolt	18 – 28	1.8 – 2.8	13.0 – 20.0
⑧ Front brake master cylinder mounting bolt	5 – 8	0.5 – 0.8	3.5 – 6.0
⑨ Front brake caliper mounting bolt	30 – 48	3.0 – 4.8	21.5 – 35.0
⑩ Front brake caliper housing bolt	30 – 36	3.0 – 3.6	21.5 – 26.0
⑪ Brake hose union bolt	15 – 20	1.5 – 2.0	11.0 – 14.5
⑫ Air bleeder valve	6 – 9	0.6 – 0.9	4.5 – 6.5
⑬ Front and rear disc bolt	18 – 28	1.8 – 2.8	13.0 – 20.0
⑭ Swingarm pivot nut	85 – 115	8.5 – 11.5	61.5 – 83.0
⑮ Rear shock absorber upper/lower mounting nut	48 – 72	4.8 – 7.2	34.5 – 52.0
⑯ Rear cushion lever mounting nut	84 – 120	8.4 – 12.0	60.5 – 87.0
⑰ Rear cushion lever rod mounting nut (Upper & Lower)	84 – 120	8.4 – 12.0	60.5 – 87.0
⑱ Rear brake caliper mounting bolt	20 – 31	2.0 – 3.1	14.5 – 22.5
⑲ Rear brake caliper housing bolt	30 – 36	3.0 – 3.6	21.5 – 26.0
⑳ Torque link nut (Front & Rear)	Normal nut with cotter pin	22 – 35	16.0 – 25.5
	Self-lock nut	25 – 39	18.0 – 28.0
㉑ Rear brake master cylinder mounting bolt	8 – 12	0.8 – 1.2	6.0 – 8.5
㉒ Rear axle nut	Normal nut with cotter pin	50 – 80	36.0 – 58.0
	Self-lock nut	55 – 88	40.0 – 63.5
㉓ Rear sprocket nut	40 – 60	4.0 – 6.0	29.0 – 43.5

2-19 PERIODIC MAINTENANCE AND TUNE-UP PROCEDURES



ENGINE

CONTENTS

COMPRESSION PRESSURE CHECK	3- 1
COMPRESSION TEST PROCEDURE	3- 1
OIL PRESSURE CHECK	3- 2
OIL PRESSURE TEST PROCEDURE	3- 2
ENGINE COMPONENTS REMOVABLE WITH ENGINE IN PLACE	3- 3
ENGINE REMOVAL AND REINSTALLATION	3- 4
ENGINE REMOVAL	3- 4
ENGINE REINSTALLATION	3- 8
ENGINE DISASSEMBLY	3-10
ENGINE COMPONENTS INSPECTION AND SERVICE	3-20
CYLINDER HEAD	3-20
VALVE	3-21
CAMSHAFT	3-27
CAM CHAIN TENSIONER	3-30
CYLINDER	3-30
PISTON	3-31
PISTON RING	3-32
PISTON PIN	3-33
CONROD	3-33
CRANKSHAFT	3-36
CLUTCH	3-40
OIL PUMP	3-41
TRANSMISSION	3-41
ENGINE REASSEMBLY	3-44

COMPRESSION PRESSURE CHECK

The compression of a cylinder is a good indicator of its internal condition.

The decision to overhaul the cylinder is often based on the results of a compression test. Periodic maintenance records kept at your dealership should include compression readings for each maintenance service.

COMPRESSION PRESSURE SPECIFICATION

Standard	Limit	Difference
1 000 – 1 450 kPa (10 – 14.5 kg/cm ²) (142 – 206 psi)	800 kPa (8 kg/cm ²) (114 psi)	200 kPa (2 kg/cm ²) (28 psi)

Low compression pressure can indicate any of the following conditions:

- * Excessively worn cylinder wall
- * Worn-down piston or piston rings
- * Piston rings stuck in grooves
- * Poor seating of valves
- * Ruptured or otherwise defective cylinder head gasket

Overhaul the engine in the following cases:

- * Compression pressure in one of the cylinders is less than 800 kPa (8 kg/cm², 114 psi).
- * Difference in compression pressure between any two cylinders is more than 200 kPa (2 kg/cm², 28 psi).
- * All compression pressure are below 1 000 kPa (10 kg/cm², 142 psi) even when they measure more than 800 kPa (8 kg/cm², 114 psi).

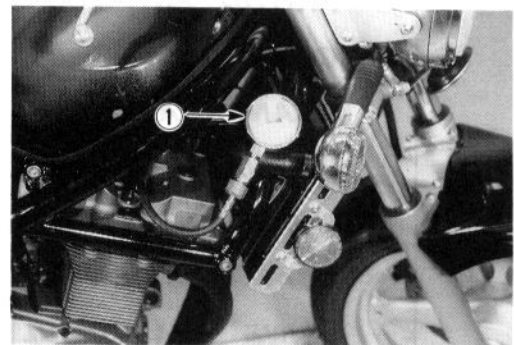
COMPRESSION TEST PROCEDURE

NOTE:

- * *Before testing the engine for compression pressure, make sure that the cylinder head nuts and bolt are tightened to the specified torque values and valves are properly adjusted.*
- * *Have the engine warmed up by idling before testing.*
- * *Be sure that the battery used is in fully-charged condition.*

Remove the parts concerned and test the compression pressure in the following manner.

- Remove the spark plugs.
- Fit the compression gauge ① one of the plug holes, taking care to make the connection tight.
- Keep the throttle grip in full-open position.
- While cranking the engine a few seconds with the starter, record the maximum gauge reading as the compression of that cylinder.
- Repeat this procedure with the other cylinders.



09915-64510: Compression gauge

09915-63310: Adaptor

OIL PRESSURE CHECK

Check periodically the oil pressure in the engine to judge roughly the condition of the moving parts.

OIL PRESSURE SPECIFICATION

<p>Above 250 kPa (2.5 kg/cm², 36 psi) Below 600 kPa (6.0 kg/cm², 85 psi)</p>	<p>at 3 000 r/min., Oil temp. at 60° C (140° F)</p>
---	---

If the oil pressure is lower or higher than the specification, the following causes may be considered.

LOW OIL PRESSURE

- * Clogged oil filter
- * Oil leakage from the oil passage way
- * Damaged oil seal
- * Defective oil pump
- * Combination of above items

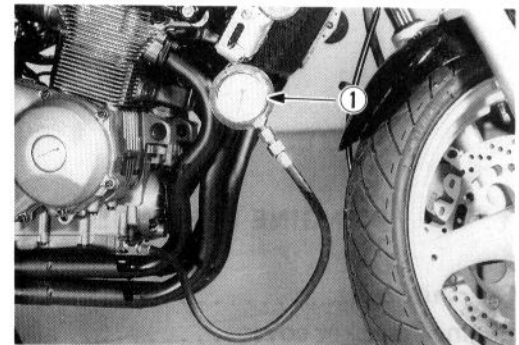
HIGH OIL PRESSURE

- * Used a engine oil which is too heavy a weight
- * Clogged oil passage way
- * Combination of above items

OIL PRESSURE TEST PROCEDURE

Start the engine and check if the oil pressure indicator light is turned on. If it keeps on lighting, check the oil pressure indicator light circuit. If it is in good condition, check the oil pressure in the following manner.

- Install the oil pressure gauge ① in the position shown in the figure.
- Warm up the engine as follows:
 Summer 10 min. at 2 000 r/min.
 Winter 20 min. at 2 000 r/min.
- After warming up, increase the engine speed to 3 000 r/min. with the engine tachometer reading, and read the oil pressure gauge.



09915-74510 : Oil pressure gauge

09915-77330 : Meter (for high pressure)

ENGINE COMPONENTS REMOVABLE WITH ENGINE IN PLACE

The parts listed below can be removed and reinstalled without removing the engine from the frame. Refer to the page listed in each section for removal and reinstallation instructions.

ENGINE CENTER

	See page
Radiator	5- 5
Exhaust pipe/muffler	3- 4
Oil pressure switch	3-49
Oil filter	3-16 and 49
Oil pan	3-17 and 48
Sump filter	3-17 and 48
Carburetors	3- 5 and 9
Cam chain tensioner	3-10 and 60
Cylinder head cover (along with cylinder head breather cover)	3-10
Camshafts	3-10 and 58
Cylinder head	3-11 and 57
Cylinder	3-11 and 56
Pistons	3-12 and 56
Starter motor	3-12 and 54

ENGINE LEFT SIDE

	See page
Gearshift lever	3- 6
Engine sprocket cover	3- 6
Water pump	3-17
Engine sprocket and drive chain	3- 6
Neutral indicator switch body	3-17
Starter clutch cover	3-10
Signal generator (pick-up coil)	6- 7
Starter idle gear	3-12
Starter clutch with signal generator rotor	3-12 and 13

ENGINE RIGHT SIDE

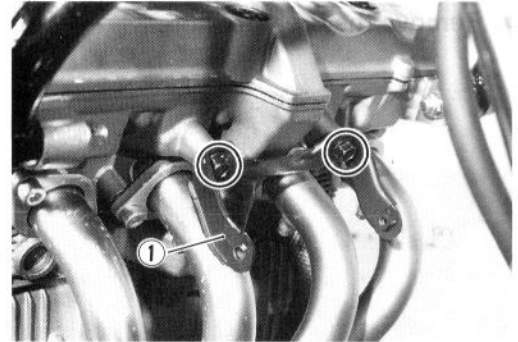
	See page
Clutch cover	3-12
Generator rotor	3-13
Generator	3-13
Clutch pressure, drive and driven plates	3-14
Clutch sleeve hub	3-14
Oil pump driven gear and oil pump	3-15
Primary driven gear	3-15
Gearshift shaft	3-16
Gearshift cam driven gear	3-16

ENGINE REMOVAL AND REINSTALLATION

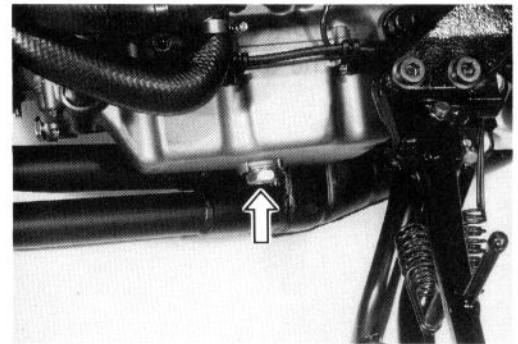
ENGINE REMOVAL

Before taking the engine out of the frame, wash the engine with a steam cleaner. The procedure of engine removal is sequentially explained in the following steps, and engine installation is effected by reversing the removal procedure.

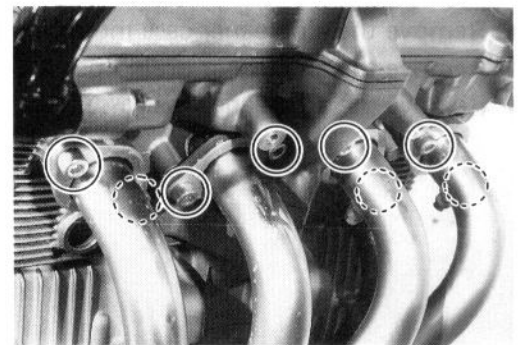
- Remove the front seat.
- Remove the air cleaner side covers, left and right. (See page 1-12.)
- Remove the fuel tank. (See page 4-2.)
- Disconnect the inlet and outlet water hoses to drain out coolant. (See page 5-5.)
- Remove the radiator. (See page 5-5.)
- Remove the radiator bracket ①.



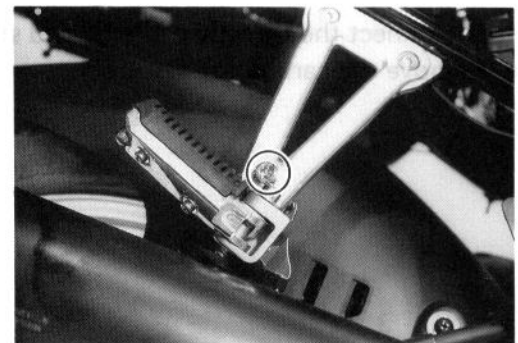
- Place an oil pan under the engine and remove the oil drain plug to drain out engine oil.



- Remove the eight exhaust pipe clamp bolts.

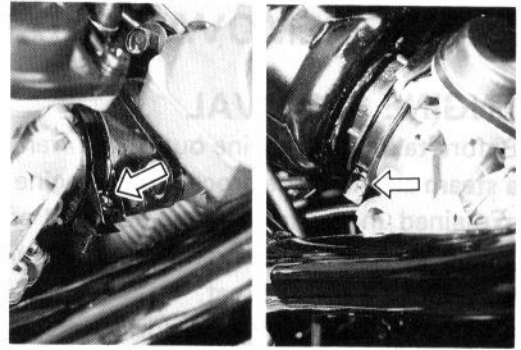


- Remove the muffler mounting bolt, then remove the exhaust pipe/muffler assembly.

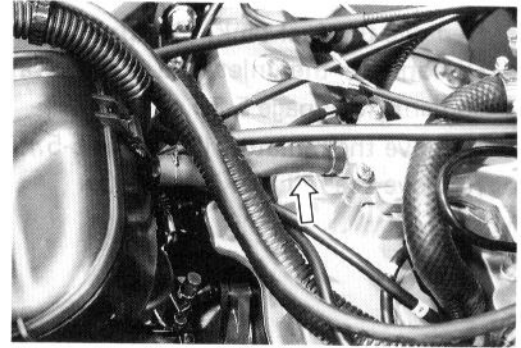


3-5 ENGINE

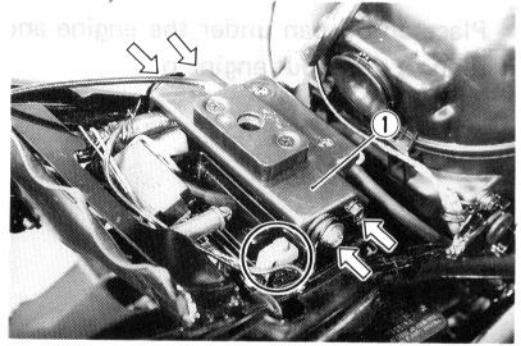
- Loosen each carburetor clamp screw.



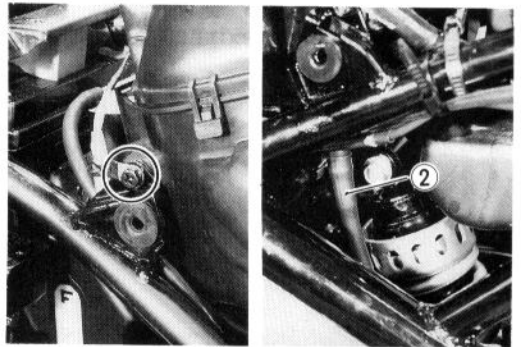
- Remove the breather hose.



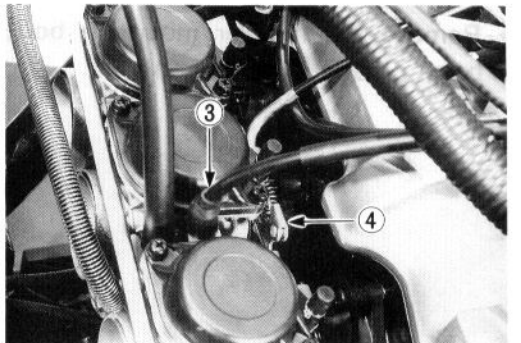
- Remove the front seat lock holder ① by removing the bolts.
- Disconnect the battery \ominus lead wire from the battery terminal.



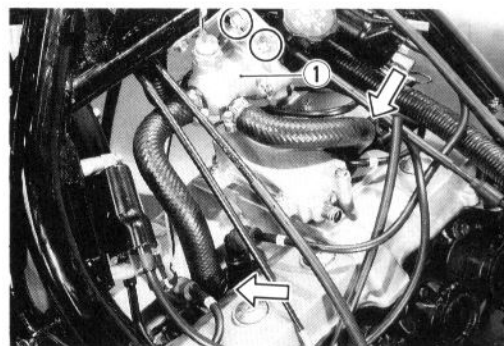
- Remove the air cleaner case mounting bolts, left and right.
- Remove the air cleaner drain hose ②.
- Remove the air cleaner case assembly.



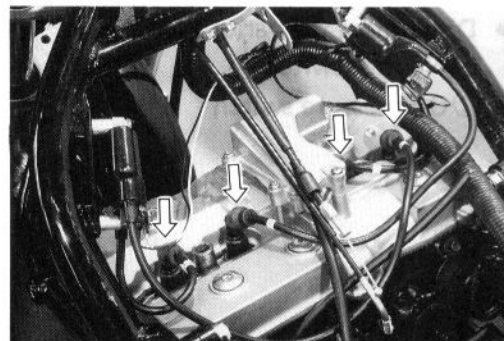
- Disconnect the throttle cable ③ and starter cable ④.
- Remove the carburetor assembly.



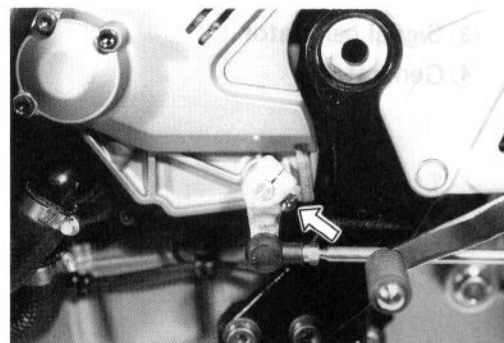
- Loosen the water hose clamp screws and disconnect the left and right water hoses from the cylinder head.
- Disconnect the water thermo-switch lead wires and cooling fan thermo-switch lead wires.
- Remove the thermostat case ① along with the left and right water hoses.



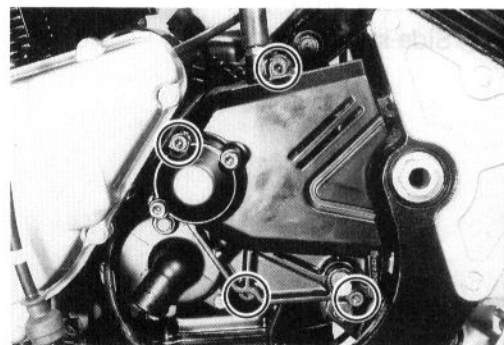
- Disconnect the spark plug caps.



- Remove the gearshift lever.



- Remove the engine sprocket cover.

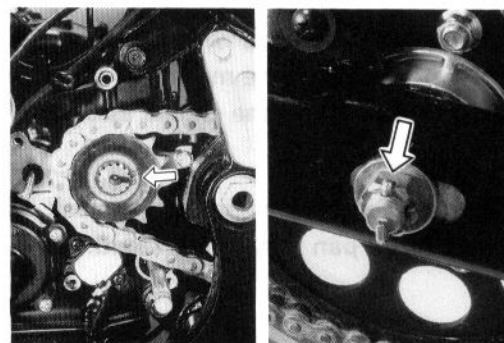


- Remove the engine sprocket by removing the circlip.

09900-06107: Snap ring pliers

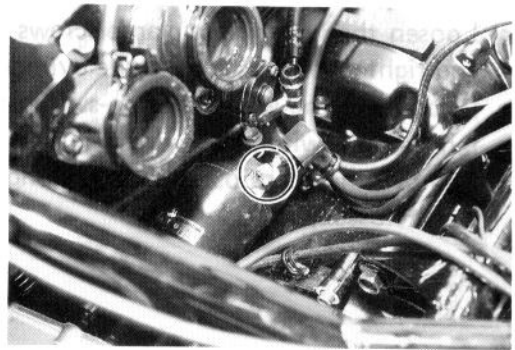
NOTE:

If it is difficult to remove the engine sprocket, loosen the axle nut and chain adjusting nuts to provide additional chain slack.



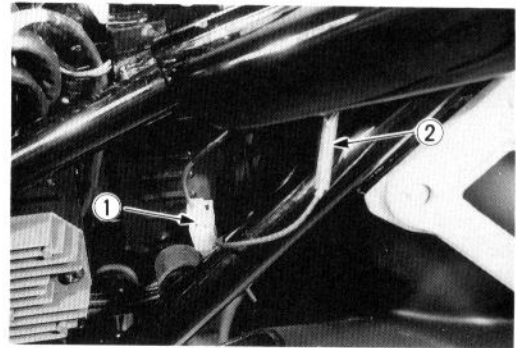
3-7 ENGINE

- Disconnect the starter motor lead wire.

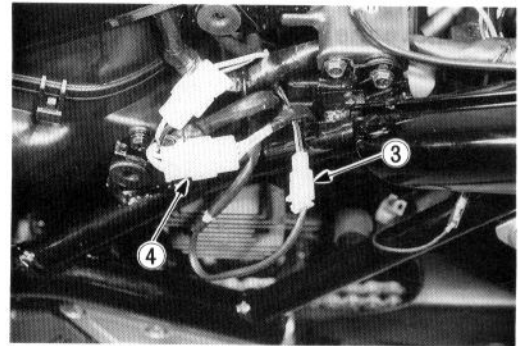


- Disconnect the various lead wires.

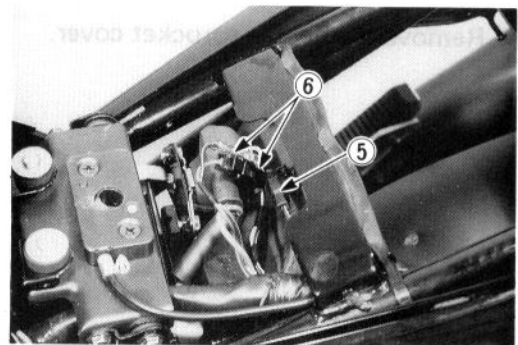
- ① Neutral switch
- ② Oil pressure switch



- ③ Signal generator
- ④ Generator



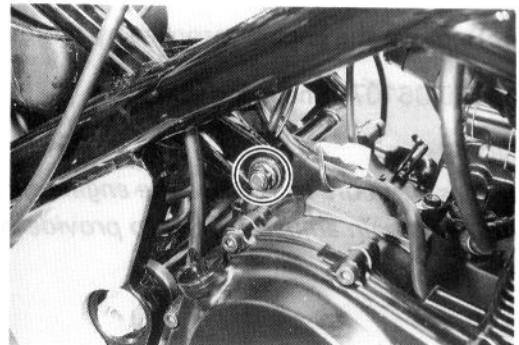
- ⑤ Battery ground
- ⑥ Side-stand switch

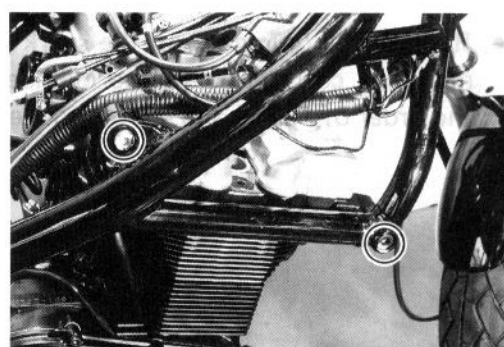
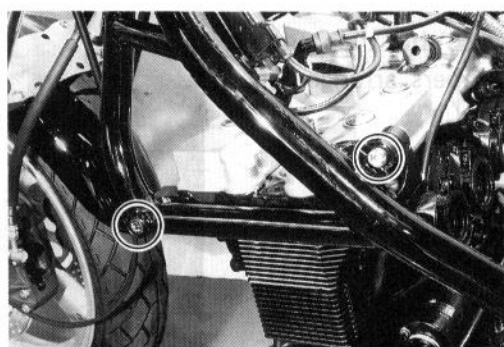
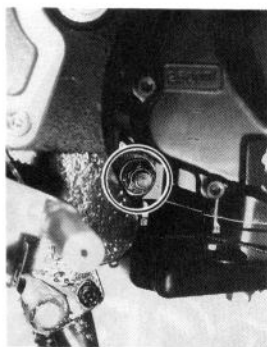


- Support the engine with a proper jack.
- Remove the engine mounting bolts and nuts.
- Gradually lower the engine assembly.

CAUTION:

When holding the engine with a jack, place a wooden piece on a jack or oil pan may be damaged.





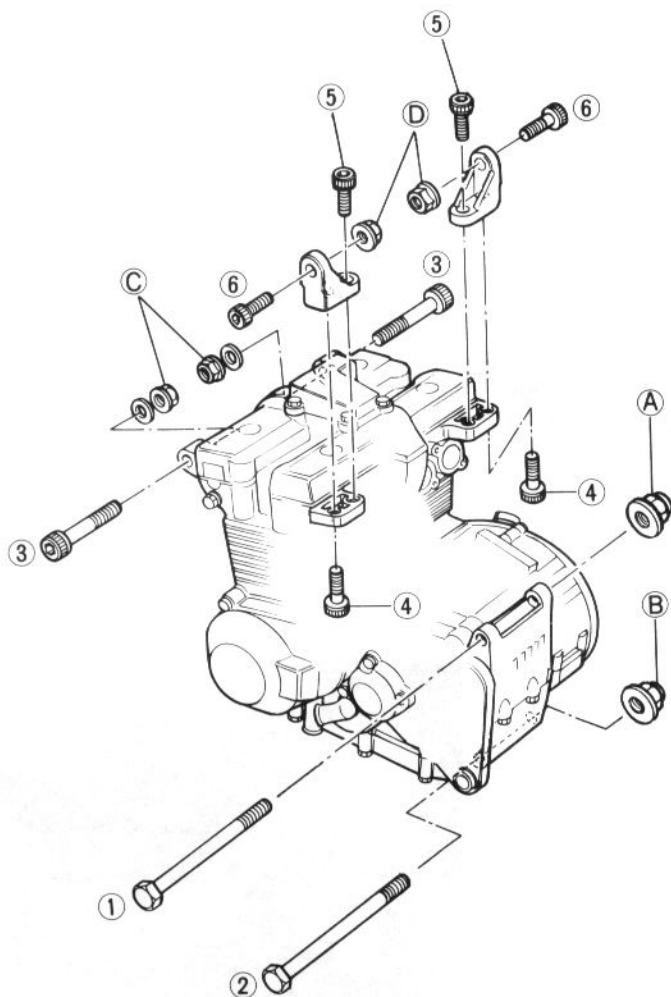
ENGINE REINSTALLATION

The engine can be installed in the reverse order of removal.

- Insert the two long bolts from left side. Install the bolts, washers and nuts properly, as shown in the following illustration.

NOTE:

The engine mounting nuts are self-locking. Once the nut has been removed, it is no longer of any use. Be sure to use new nuts and tighten them to the specified torque.



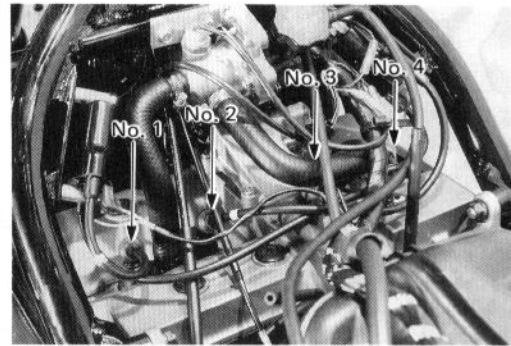
BOLT LENGTH

①	135 mm (5.3 in)
②	145 mm (5.7 in)
③	70 mm (2.8 in)
④	30 mm (1.2 in)
⑤	25 mm (1.0 in)
⑥	30 mm (1.2 in)

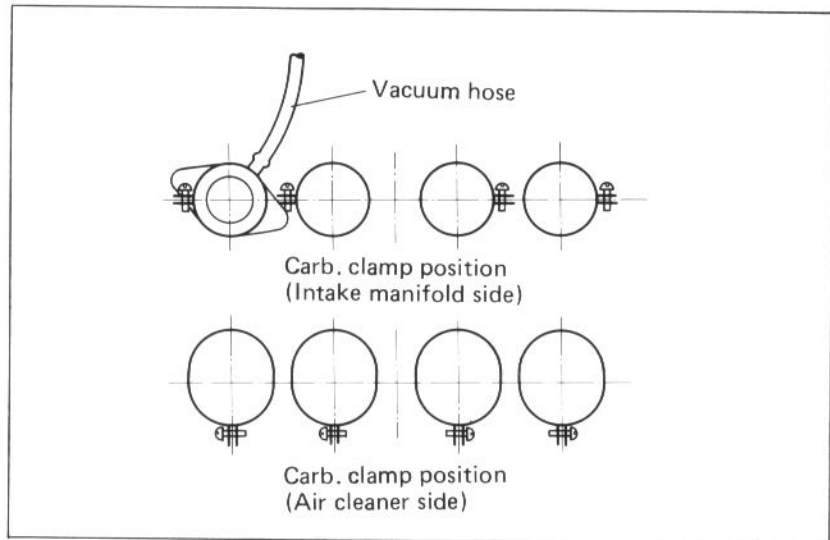
TIGHTENING TORQUE

ITEM	N·m	kg·m	lb·ft
A B C	60 – 72	6.0 – 7.2	43.5 – 52.0
④ ⑤ D	22 – 30	2.2 – 3.0	16.0 – 21.5

- Replace the plug caps on the spark plugs so that their code markings correspond to the cylinder numbers arranged in the order of **1, 2, 3** and **4** from the left hand.



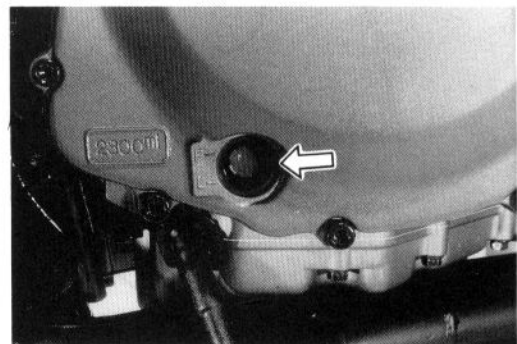
- Locate the carburetor clamps, as shown in the following illustration.



- After remounting the engine, route wiring harness, cables and hoses properly by referring to the sections, for wire routing, cable routing and hose routing. (See pages 8-12 through 20.)
- Adjust the following items to the specification.

	Page
* Filling coolant	2-10
* Clutch cable play	2-10
* Throttle cable play	2-9
* Idling adjustment	2-9
* Balancing carburetors	4-12
* Drive chain	2-11

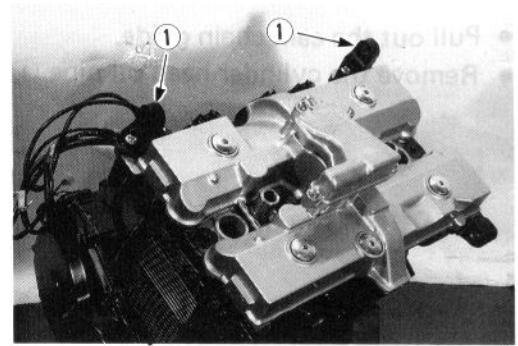
- Pour 3.2 L (3.4/2.8 US/Imp qt) of engine oil SAE 10W/40 graded SE or SF into the engine after overhauling engine.
- Start up the engine and allow it run for several minutes at idle speed. About several minutes after stopping engine, check that the oil level remains between the marks of oil level inspection window.



Change	2300 ml (2.4/2.0 US/Imp qt)
Filter change	2800 ml (3.0/2.5 US/Imp qt)
Overhaul	3200 ml (3.4/2.8 US/Imp qt)

ENGINE DISASSEMBLY

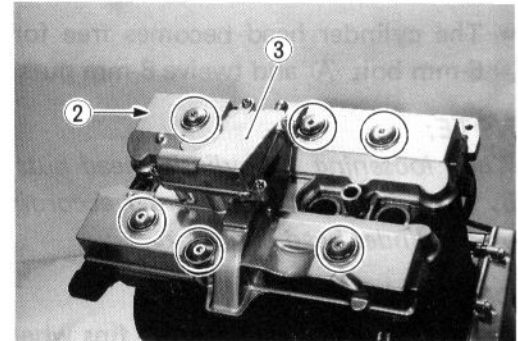
- Remove the engine mounting brackets ①.



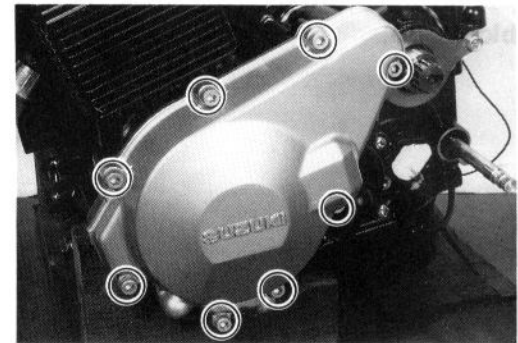
- Remove the cylinder head cover ②.

NOTE:

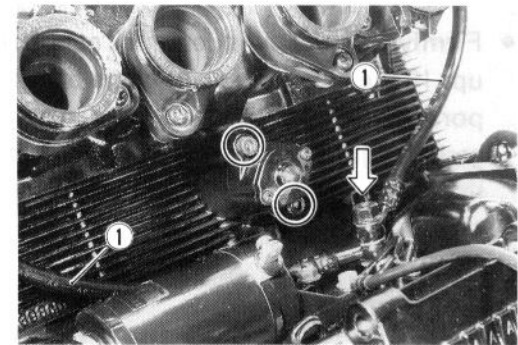
When removing the cylinder head cover ②, do not remove the breather cover ③.



- Remove the starter clutch cover.



- Remove the cam chain tensioner.
- Remove the left and right oil hoses ①.

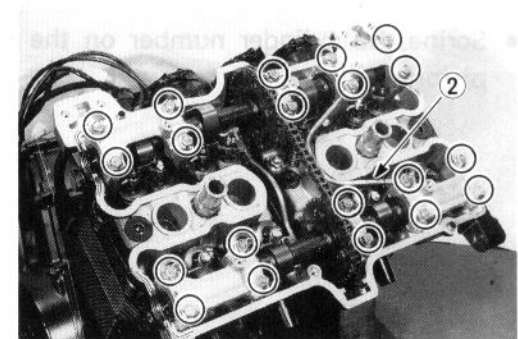


- Remove the camshaft journal holders and cylinder head oil pipe ②.

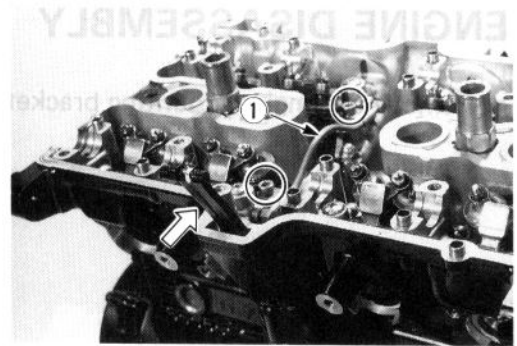
NOTE:

Be sure to loosen camshaft journal holder bolts evenly by shifting the wrench diagonally.

- Remove the two camshafts, intake and exhaust.



- Pull out the cam chain guide.
- Remove the cylinder head oil pipe ①.



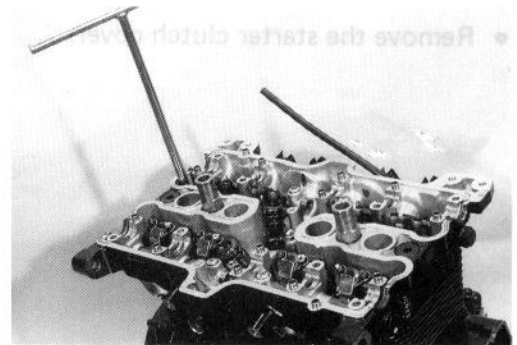
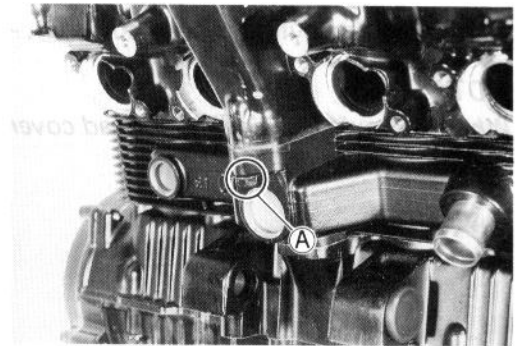
- The cylinder head becomes free for removal when its one 6-mm bolt ① and twelve 8-mm nuts are removed.

NOTE:

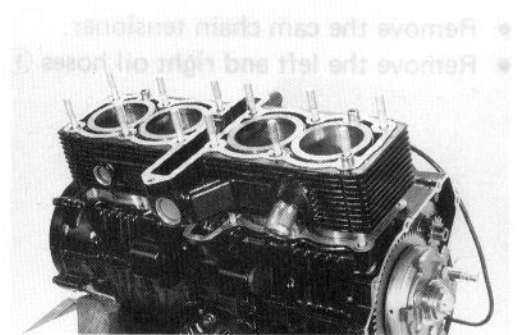
When loosening the cylinder head nuts, loosen each nut little by little in a descending order according to the numbers cast on a cylinder head.

CAUTION:

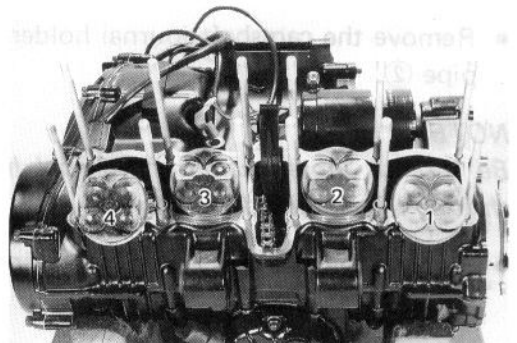
Be careful not to damage the fins when removing or handling the cylinder head. This precaution applies to the cylinder block also.



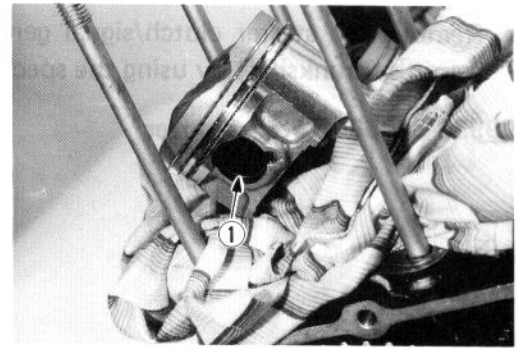
- Firmly grip the cylinder block at both ends, and lift it straight up. If the block does not come off, lightly tap on the finless portions of the block with a plastic mallet to make the gasketed joint loose.



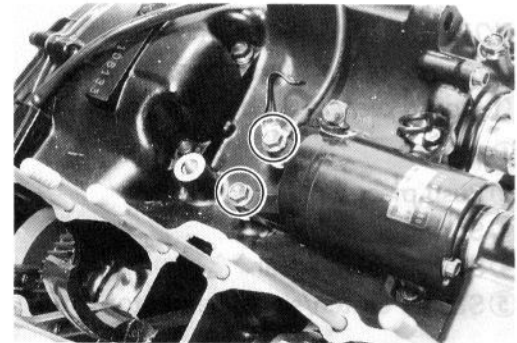
- Scribe the cylinder number on the head of the respective pistons.



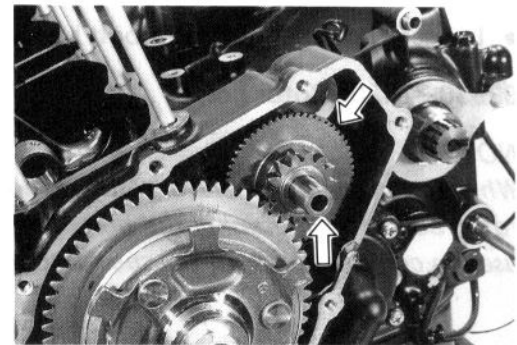
- Place a cloth beneath the piston so as not to drop any parts in the crankcase, and remove the circlip ① with long-nose pliers.
- Draw out the piston pin. Place each piston pin in the same piston as that it was removed from.



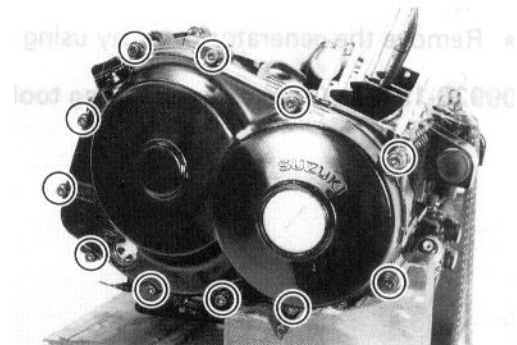
- Remove the starter motor.



- Remove the starter idle gear and its shaft.



- Remove the clutch cover.

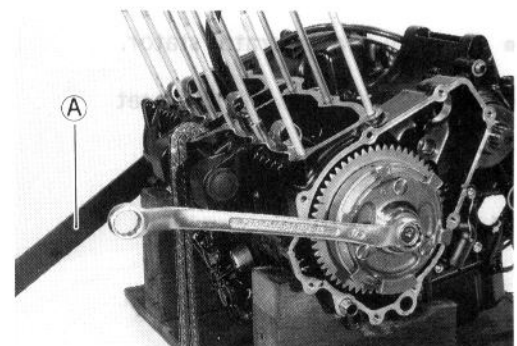


- Loosen the starter clutch mounting bolt by holding the generator rotor with the special tool ①.

09930-32420: Rotor holder

NOTE:

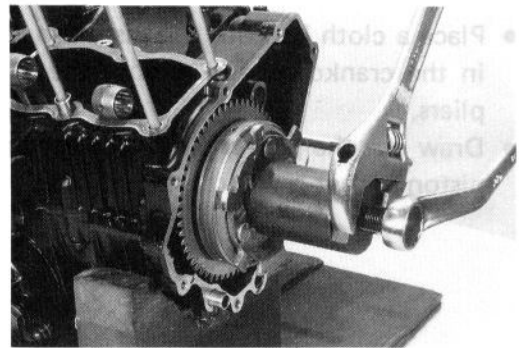
When removing the starter clutch assembly from the crankshaft, do not remove the starter clutch mounting bolt after loosening the bolt. The starter clutch mounting bolt is used in conjunction with the special tool.



3-13 ENGINE

- Remove the starter clutch/signal generator rotor assembly from the crankshaft by using the special tool.

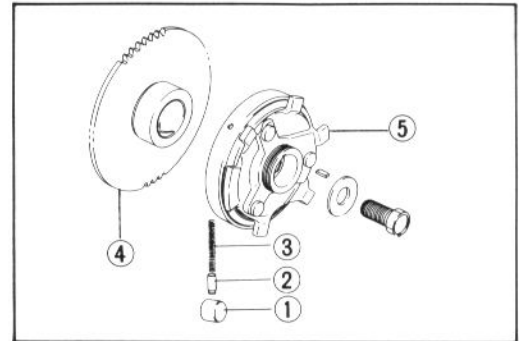
09930-34960: Rotor remover



NOTE:

When removing the starter driven gear ④, do not lose rollers ①, push pieces ② and springs ③.

- ① Roller
- ② Push piece
- ③ Spring
- ④ Starter driven gear
- ⑤ Starter clutch/signal generator rotor

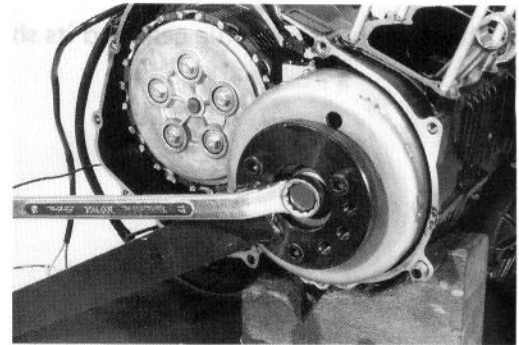


- Loosen the generator rotor bolt by using the special tool.

09930-32420: Rotor holder

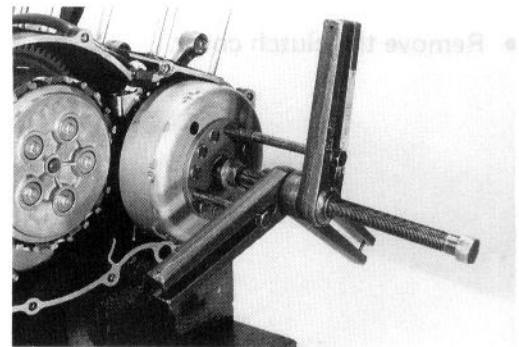
NOTE:

When removing the generator rotor, do not remove the generator rotor bolt after loosening the bolt. The generator rotor bolt is used in conjunction with the special tool.



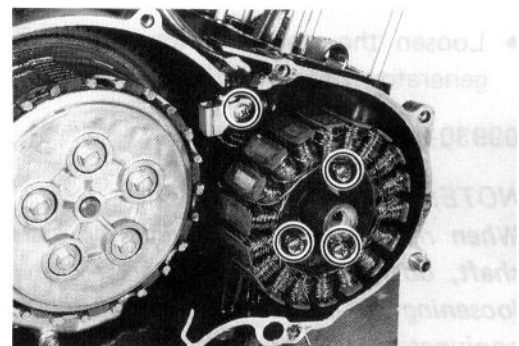
- Remove the generator rotor by using the special tool.

09920-13120: Crankcase separating tool

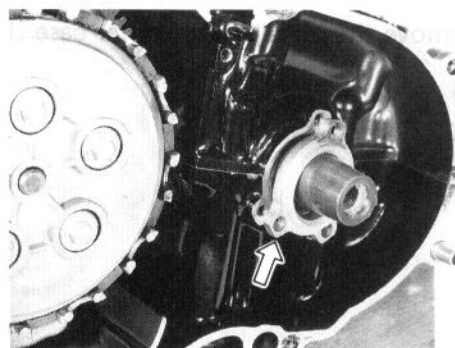


- Remove the generator stator.

09900-09003: Impact driver set



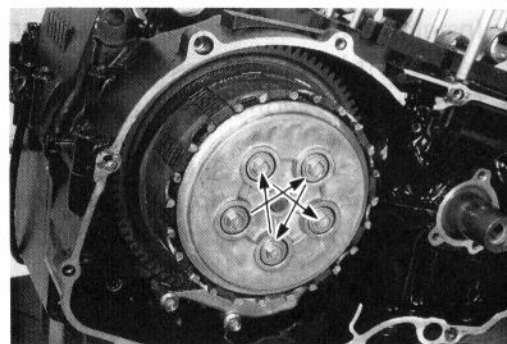
- Remove the generator stator spacer.



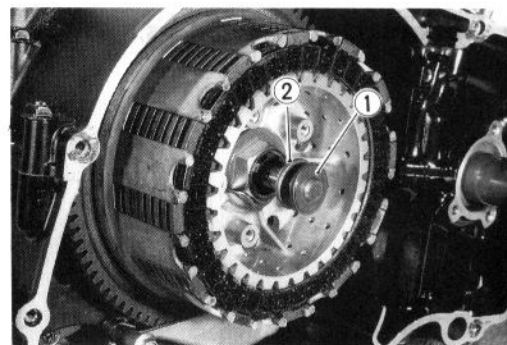
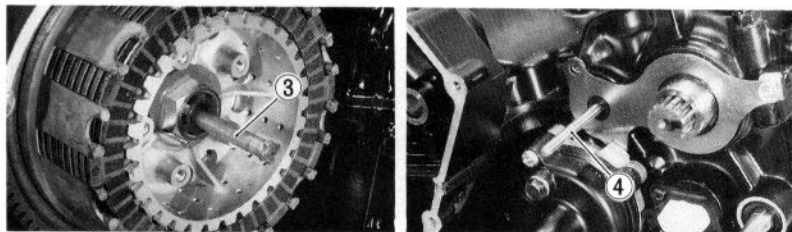
- Holding the conrod with a conrod stopper, remove the clutch spring set bolts diagonally.

09910-20116: Conrod stopper

- Remove the clutch pressure plate.



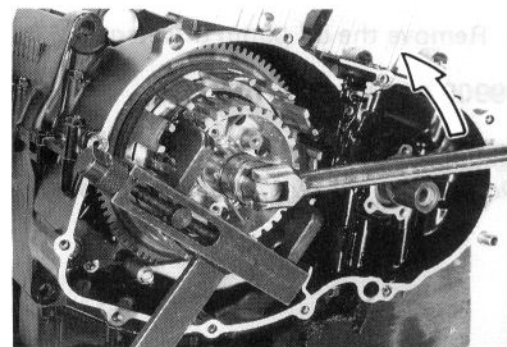
- Remove the thrust bearing ① and clutch push piece ②, and then remove the clutch push rods, ③ and ④.



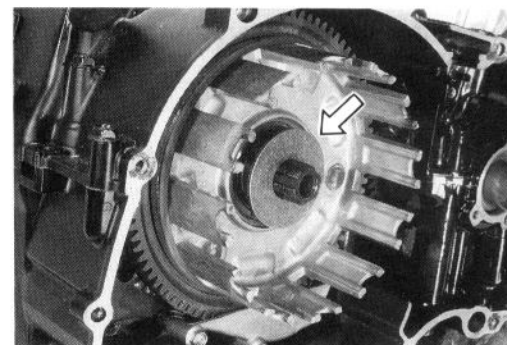
- After removal of clutch drive and driven plates, flatten the lock washer and remove the clutch sleeve hub nut by using the special tool.

09920-53710: Clutch sleeve hub holder

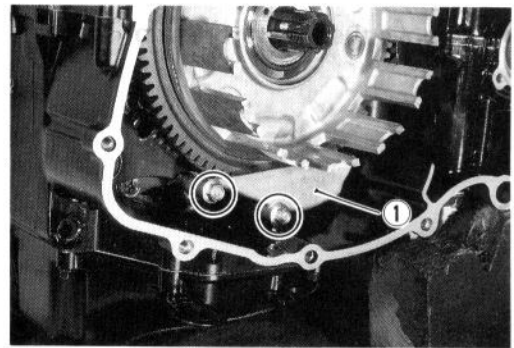
- Remove the clutch sleeve hub.



- Remove the thrust washer.



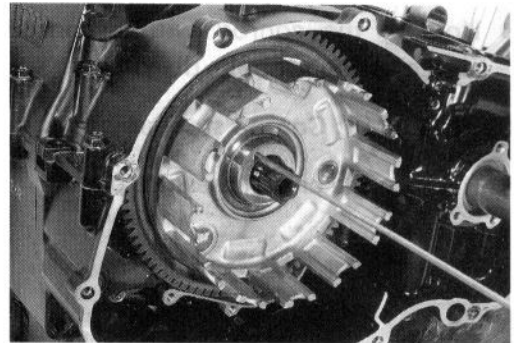
- Remove the oil separator outer case ①.



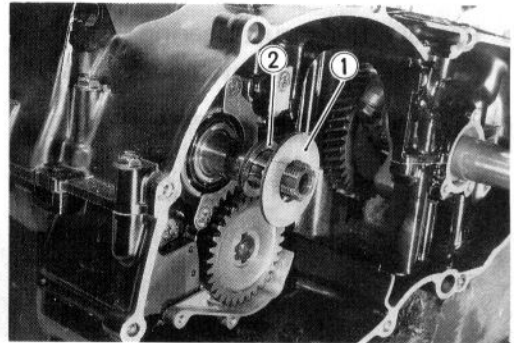
- Install a 4-mm screw into the primary driven gear spacer to ease out it by pulling.
- Remove the bearing.

NOTE:

With the spacer removed, the primary driven gear is free to disengage from the primary drive gear.



- Remove the thrust washers, ① and ②.

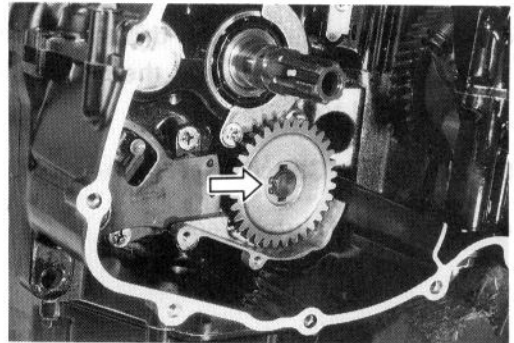


- Remove the oil pump driven gear.

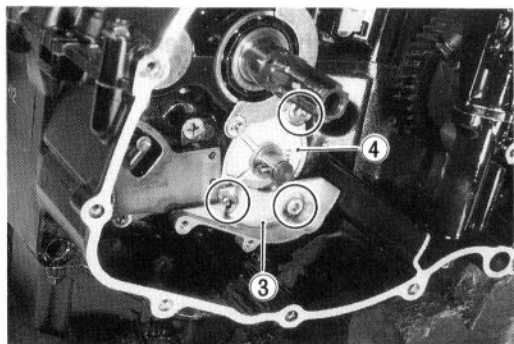
09900-06107: Snap ring pliers

NOTE:

Do not lose the circlip, pin and washer.

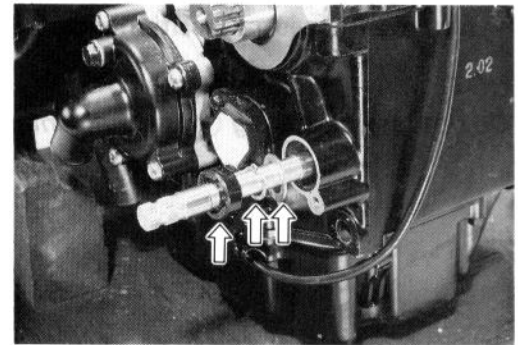


- Remove the oil separator inner case ③ and oil pump ④.

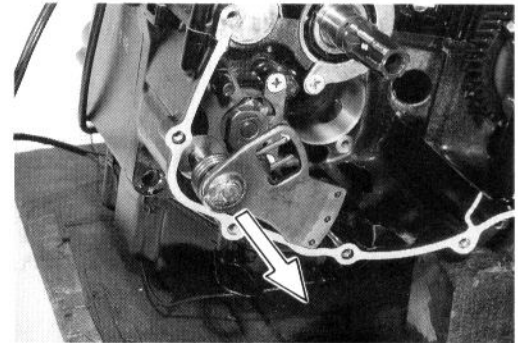


- Remove the gearshift shaft oil seal, circlip and washer.

09900-06107: Snap ring pliers



- Draw out the gearshift shaft.

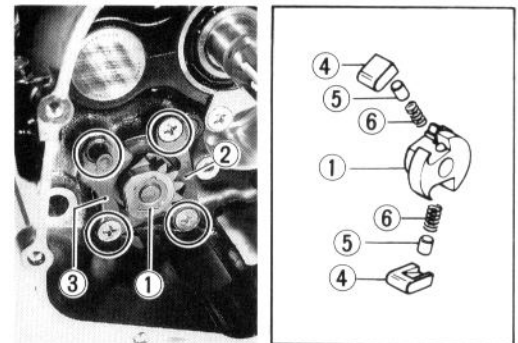


- Remove the cam driven gear ① by removing the cam guide ② and pawl lifter ③.

09900-09003: Impact driver set

NOTE:

When removing the cam driven gear, do not lose the gear shifting pawl ④, pin ⑤ and spring ⑥.

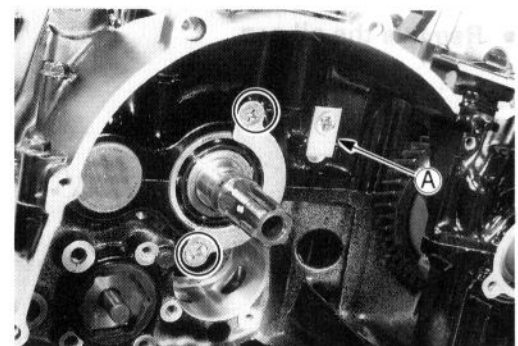


- Remove the countershaft bearing retainer.

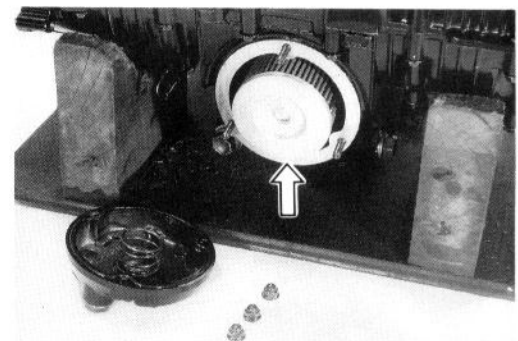
09900-09003: Impact driver set

NOTE:

Do not remove the oil gallery plug retainer (A).



- Remove the oil filter cap and oil filter.

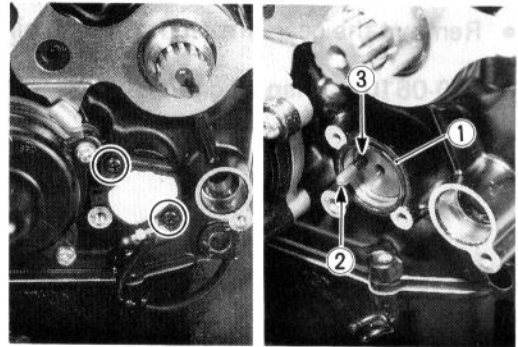


3-17 ENGINE

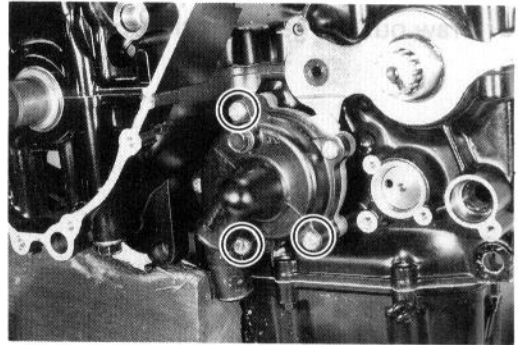
- Remove the neutral position indicator switch.

NOTE:

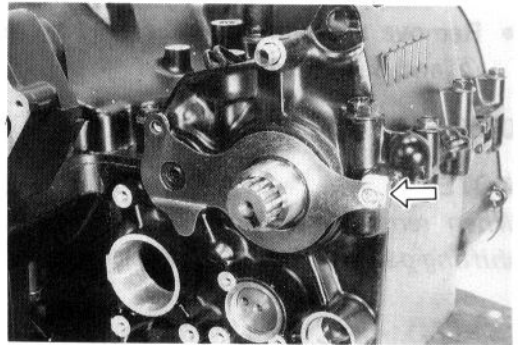
Do not lose the O-ring ①, switch contact ② and its spring ③.



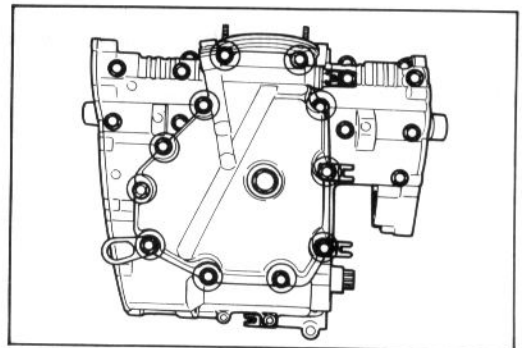
- Remove the water pump.



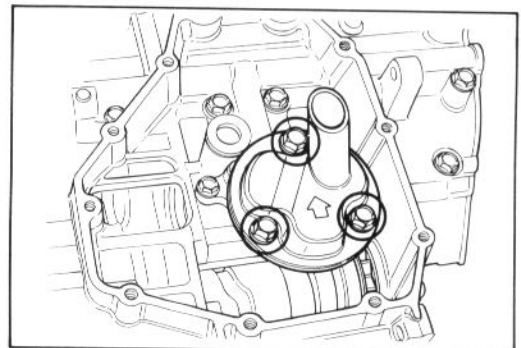
- Remove the oil seal retainer.



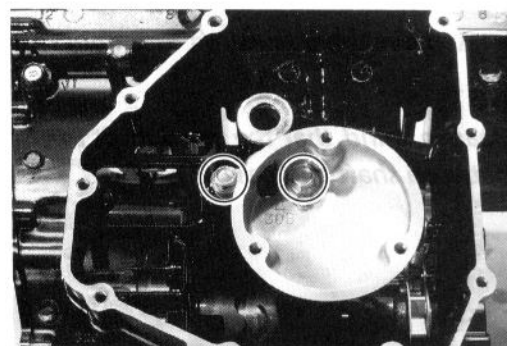
- Remove the oil pan.



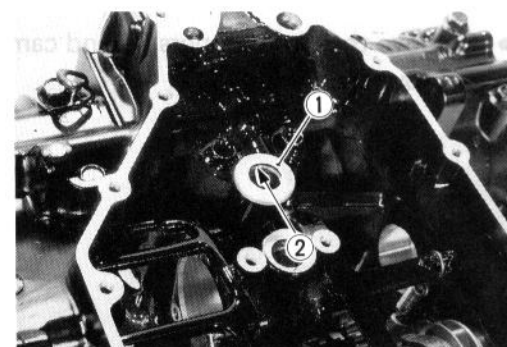
- Remove the oil sump filter.



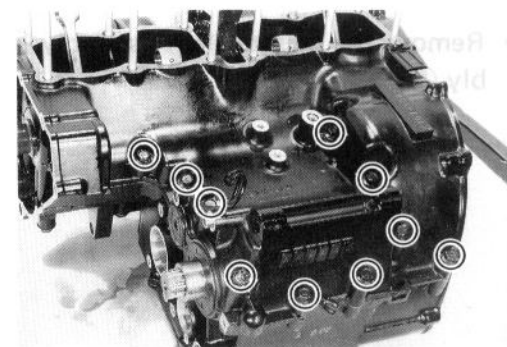
- Remove the oil sump filter guide and its O-ring.



- Remove the shim ① and O-ring ②.



- Remove the upper crankcase securing bolts.



- Remove the lower crankcase securing bolts.
- When removing the crankshaft tightening bolts, loosen them in the descending order of numbers assigned to these bolts.

NOTE:

Two allen bolts are used for tightening crankshaft at the portion **A**.

09914-25811: 6-mm "T" type hexagon wrench

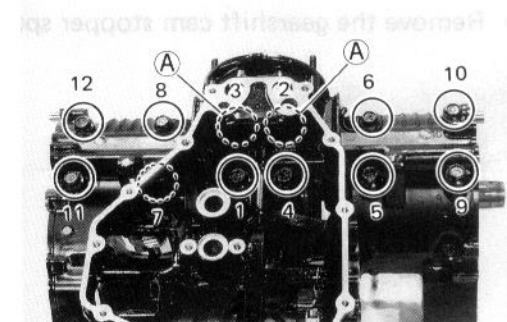
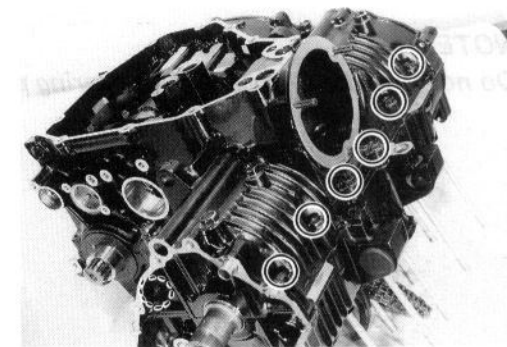
09900-00410: Hexagon wrench set

- Make sure that all bolts are removed without fail. Hammer lightly the lower crankcase side with a plastic hammer to separate the upper and lower crankcase halves and then lift the latter.

09912-34510: Cylinder disassembler

CAUTION:

Do not drop the crankshaft journal bearings from the lower crankcase.

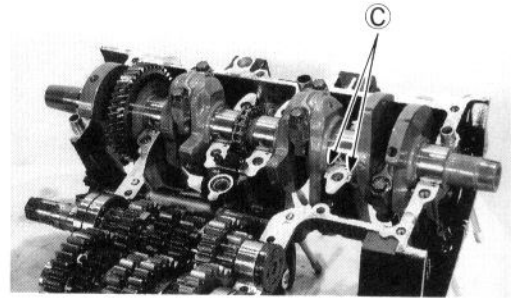


3-19 ENGINE

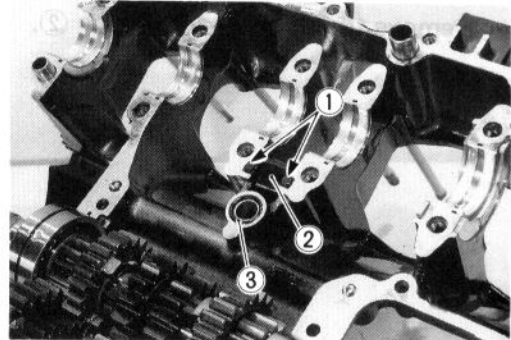
- Remove the crankshaft assembly from the upper crankcase.

NOTE:

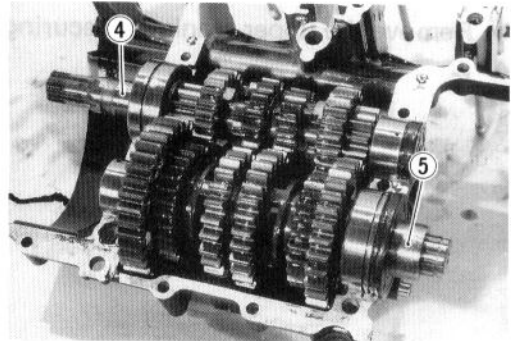
*Bear in mind that the crankshaft thrust bearings **C** are located between shaft and case.*



- Remove the two dampers **1** and cam chain guide **2**.
- Remove the O-ring **3**.

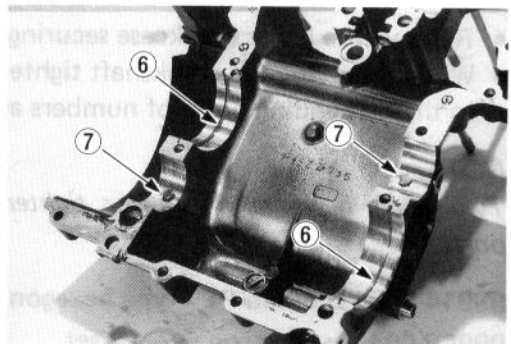


- Remove the countershaft assembly **4** and driveshaft assembly **5**.

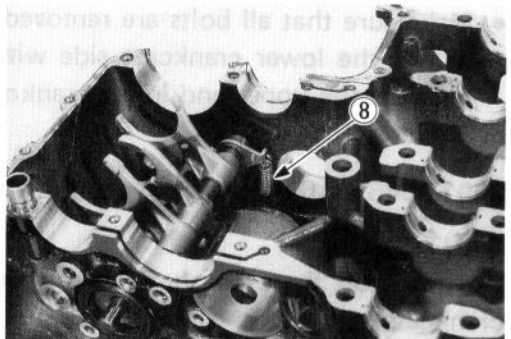


NOTE:

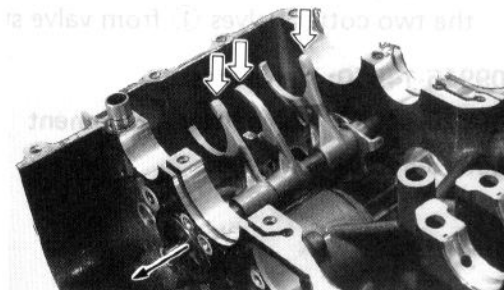
*Do not lose the C-rings **6** and bearing pins **7**.*



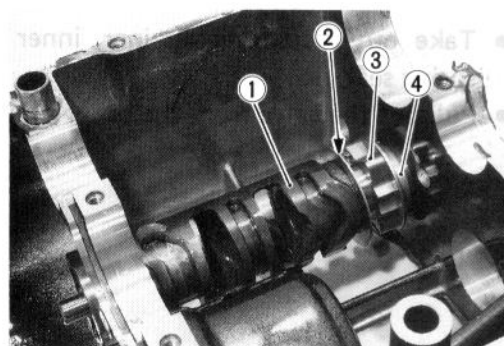
- Remove the gearshift cam stopper spring **8**.



- Hold the gearshift forks by hand to draw out the gearshift fork shaft.



- Remove the gearshift cam ①, washer ②, gearshift cam stopper plate ③ and spacer ④.



ENGINE COMPONENTS INSPECTION AND SERVICE

CYLINDER HEAD

CAUTION:

Be sure to identify each removed part as to its location, and lay the parts out in groups designated as "No. 1", "No. 2", "Exhaust", "Inlet", so that each will be restored to the original location during assembly.

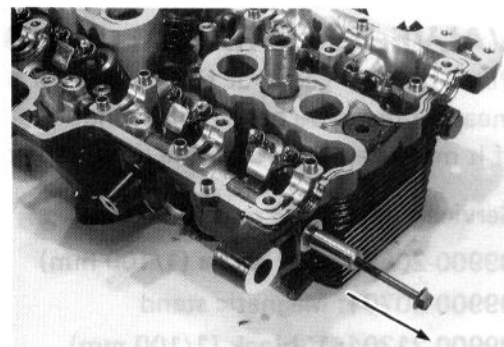
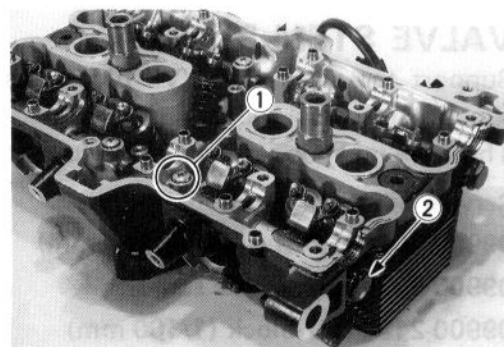
NOTE:

- * When removing the rocker arm shaft, remove the rocker arm shaft set screw ① and plug ②, screw a 6 mm bolt into the rocker arm shaft end and pull it out.
- * Removal of valves completes ordinary disassembling work. If valve guides have to be removed (for replacement after inspecting related parts) carry out the steps shown in valve guide servicing.
- * When installing the rocker arm shaft, apply SUZUKI MOLY PASTE to its surface.
- * Tighten the set screw ① and plug ② to the specified torque.

Tightening torque

Set screw ①: 8 – 10 N·m (0.8 – 1.0 kg·m, 6.0 – 7.0 lb·ft)

Plug ②: 25 – 30 N·m (2.5 – 3.0 kg·m, 18.0 – 21.5 lb·ft)

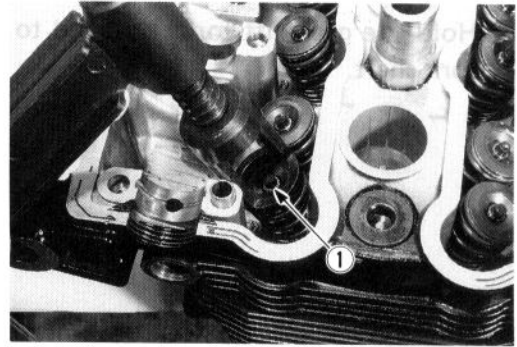


- Using special tools, compress the valve springs and take off the two cotter halves ① from valve stem.

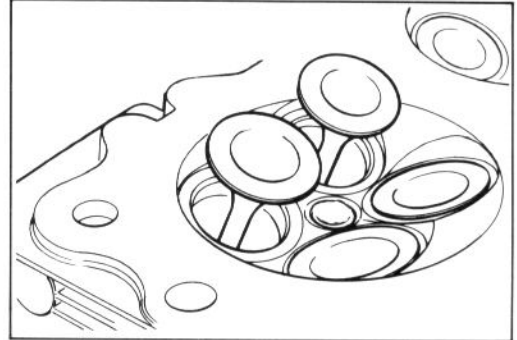
09916-14510: Valve lifter

09916-14910: Valve lifter attachment

09916-84510: Tweezers



- Take out the spring retainer, inner and outer springs and spring seat.
- Pull out the valve from the other side.



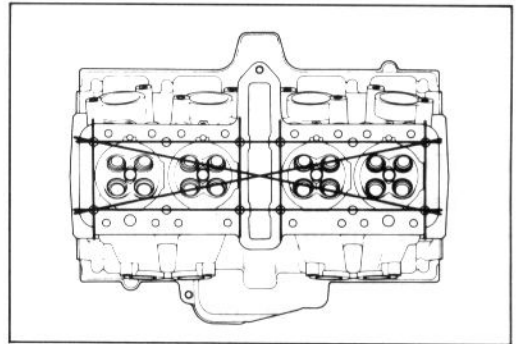
CYLINDER HEAD DISTORTION

Remove the carbon deposits.

Check the gasketed surface of the cylinder head for distortion with a straightedge and thickness gauge, taking a clearance reading at several places indicated. If the largest reading at any position of the straightedge exceeds the limit, replace the cylinder head.

09900-20803: Thickness gauge

Service Limit: 0.2 mm (0.008 in)



VALVE STEM RUNOUT

Support the valve with "V" blocks, as shown, and check its runout with a dial gauge.

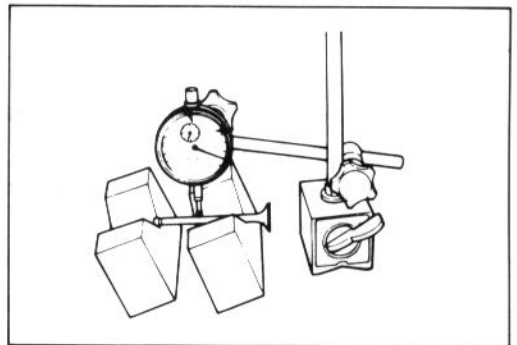
The valve must be replaced if the runout exceeds the limit.

Service Limit: 0.05 mm (0.002 in)

09900-20606: Dial gauge (1/100 mm)

09900-20701: Magnetic stand

09900-21304: V-block (1/100 mm)



VALVE HEAD RADIAL RUNOUT

Place the dial gauge at right angles to the valve head face, and measure the valve head radial runout.

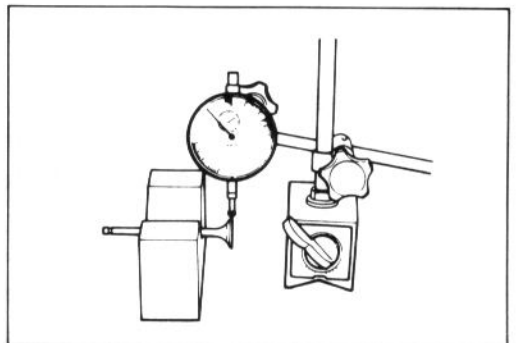
If it measures more than the limit, replace the valve.

Service Limit: 0.03 mm (0.001 in)

09900-20606: Dial gauge (1/100 mm)

09900-20701: Magnetic stand

09900-21304: V-block (1/100 mm)

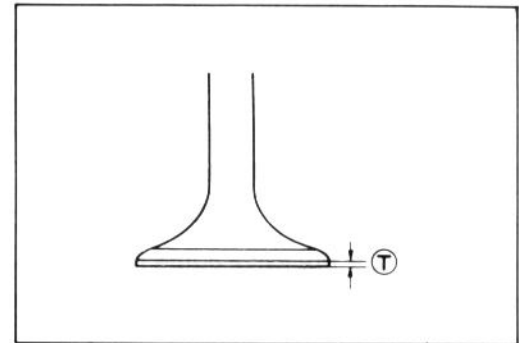


VALVE FACE WEAR

Visually inspect each valve for wear of its seating face. Replace any valve with an abnormally worn face.

The thickness ① decreases as the wear of the face advances. Measure the thickness and, if the thickness is found to have been reduced to the limit, replace it.

Service Limit ①: 0.5 mm (0.02 in)



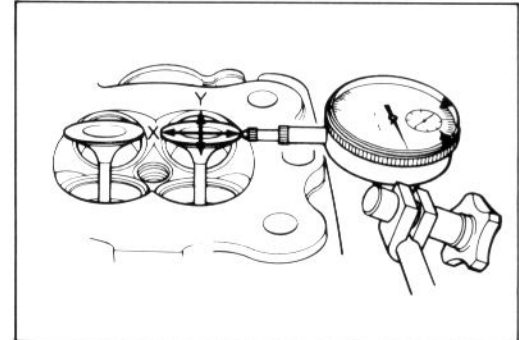
VALVE STEM DEFLECTION

Lift the valve about 10 mm (0.39 in) from the valve seat. Measure the valve stem deflection in two directions, "X" and "Y", perpendicular to each other, by positioning the dial gauge as shown. If the deflection measured exceeds the limit, (see below) then determine whether the valve or the guide should be replaced with a new one.

Service Limit

Intake valves : 0.35 mm (0.014 in)

Exhaust valves: 0.35 mm (0.014 in)



VALVE STEM WEAR

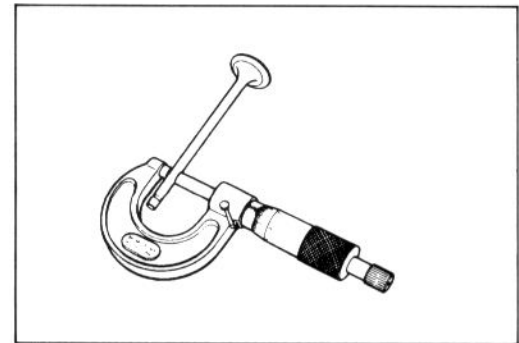
If the valve stem is worn down to the limit, as measured with a micrometer, where the clearance is found to be in excess of the limit indicated, replace the valve; if the stem is within the limit, then replace the guide. After replacing valve or guide, be sure to recheck the clearance.

09900-20205: Micrometer (0 – 25 mm)

Standard

Intake valves : 4.460 – 4.475 mm (0.1756 – 0.1762 in)

Exhaust valves: 4.445 – 4.460 mm (0.1750 – 0.1756 in)



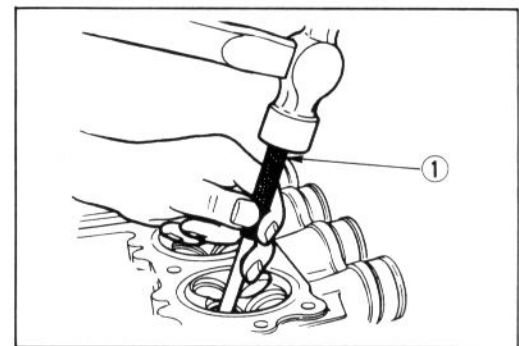
VALVE GUIDE SERVICING

- Using the valve guide remover ①, drive the valve guide out toward intake or exhaust camshaft side.

09916-43210: Valve guide remover/installer

NOTE:

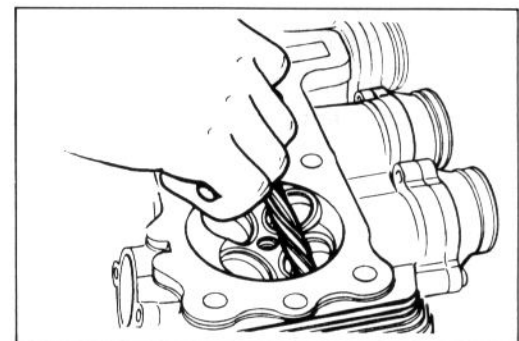
- * *Discard the removed valve guide subassemblies.*
- * *Only oversized valve guides are available as replacement parts. (Part No. 11115-32C70)*



- Re-finish the valve guide holes in cylinder head with the reamer and handle.

09916-34580: Valve guide reamer

09916-34542: Reamer handle



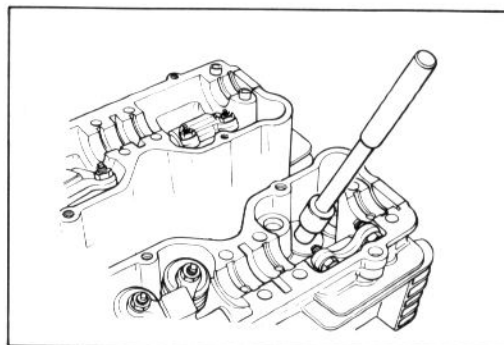
- Oil the stem hole, too, of each valve guide and drive the guide into the guide hole with the valve guide installer.

09916-43210: Valve guide remover/installer

09916-43220: Attachment

CAUTION:

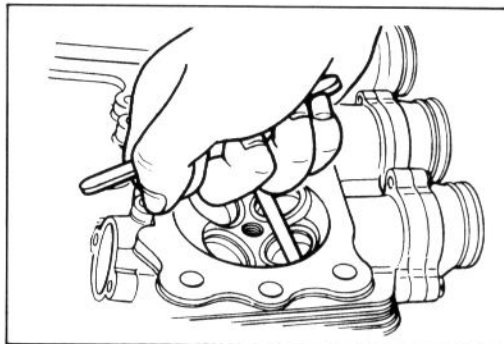
Failure to oil the valve guide hole before driving the new guide into place may result in a damaged guide or head.



- After fitting the valve guides, re-finish their guiding bores with the reamer. Be sure to clean and oil the guides after reaming.

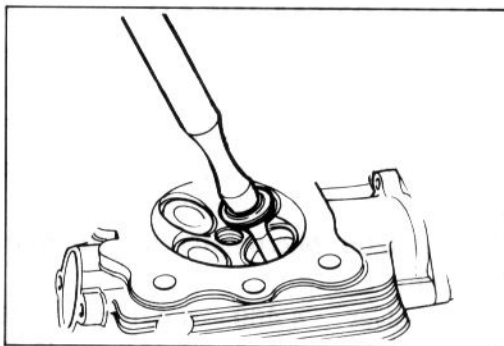
09916-33210: Valve guide reamer

09916-34542: Reamer handle



VALVE SEAT WIDTH

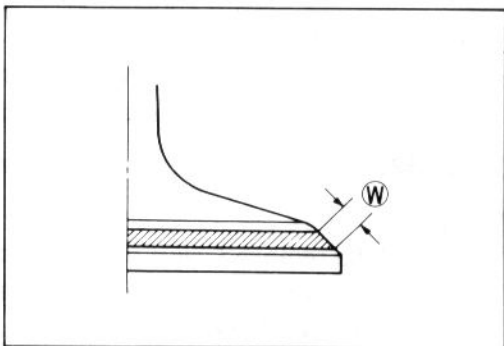
- Coat the valve seat with prussian blue uniformly. Fit the valve and tap the coated seat with the valve face in a rotating manner, in order to obtain a clear impression of the seating contact. In this operation, use the valve lapper to hold the valve head.
- The ring-like dye impression left on the valve face must be continuous-without any break. In addition, the width of the dye ring, which is the visualized seat "width", must be within the following specification:



Standard

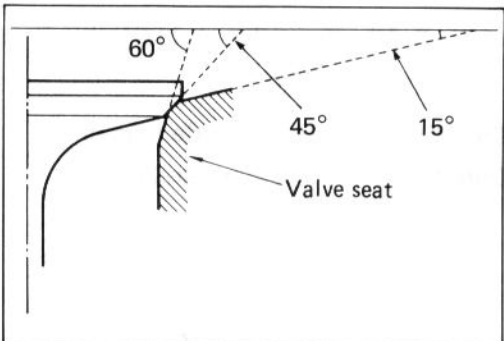
Valve seat width W : 0.7 – 0.9 mm (0.03 – 0.04 in)

If either requirement is not met, correct the seat by servicing it as follows:



VALVE SEAT SERVICING

The valve seats for both intake and exhaust valves are machined to three different angles. The seat contact surface is cut 45°.



	Intake side	Exhaust side
45°	N-122	N-131
15°	N-121	N-130
60°	N-111	N-111

(For U.S.A. model)

Valve seat cutter: (N-121),(N-122),(N-130),(N-131) and (N-111)

Solid pilot : (N-100-4.5)

(For the other models)

09916-20610: Valve seat cutter (N-121)

09916-20620: Valve seat cutter (N-122)

09916-24460: Valve seat cutter (N-130)

09916-24470: Valve seat cutter (N-131)

09916-24410: Valve seat cutter (N-111)

09916-20640: Solid pilot (N-100-4.5)

09916-21110: Valve seat cutter set

NOTE:

The valve seat contact area must be inspected after each cut.

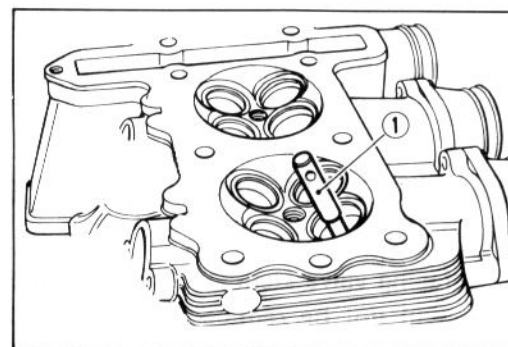
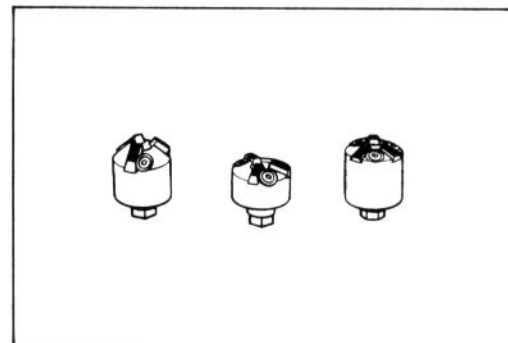
- Insert the solid pilot ① with a slight rotation. Seat the pilot snugly. Install the 45° cutter, attachment and T-handle.
- Using the 45° cutter, descale and clean up the seat with one or two turns.
- Inspect the seat by the previously described seat width measurement procedure. If the seat is pitted or burned, additional seat conditioning with the 45° cutter is required.

NOTE:

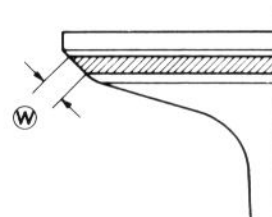
Cut only the minimum amount necessary from the seat to prevent the possibility of the valve stem becoming too close to the rocker arm for correct valve contact angle.

If the contact area is too high on the valve, or if it is too wide, use the 15°/60° cutter to lower and narrow the contact area.

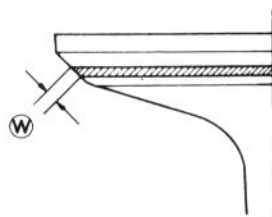
If the contact area is too low or too narrow, use the 45° cutter to raise and widen the contact area.



Contact area too high and too wide on face of valve



Contact area too low and too narrow on face of valve



- After the desired seat position and width is achieved, use the 45° cutter very lightly to clean up any burrs caused by the previous cutting operations.

CAUTION:

DO NOT use lapping compound after the final cut is made. The finished valve seat should have a velvety smooth finish and not a highly polished or shiny finish. This will provide a soft surface for the final seating of the valve which will occur during the first few seconds of engine operation.

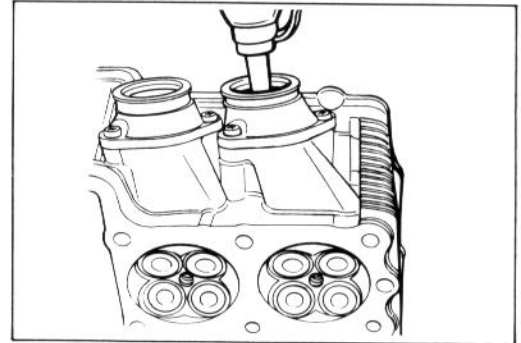
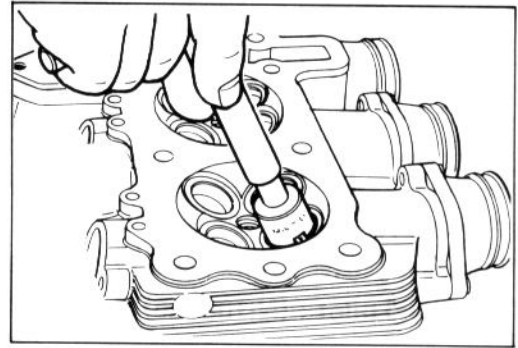
- Clean and assemble the head and valve components. Fill the intake and exhaust ports with gasoline to check for leaks. If any leaks occur, inspect the valve seat and face for burrs or other things that could prevent the valve from sealing.

WARNING:

Always use extreme caution when handling gasoline.

NOTE:

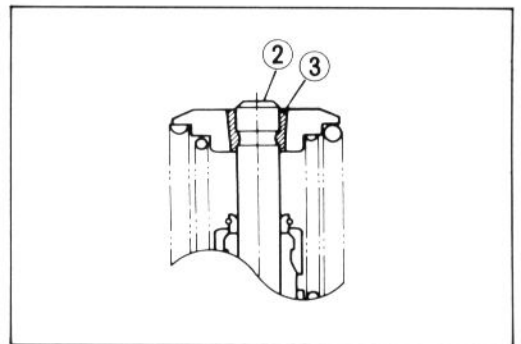
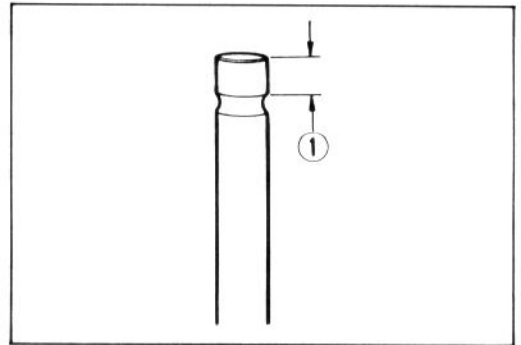
After servicing the valve seats, be sure to adjust the valve clearance after the cylinder head has been reinstalled. (see page 2-5.)



VALVE STEM END CONDITION

CAUTION:

- * Refacing valve stem end face is permissible where the length ① will not be reduced to less than 2.7 mm. If this length becomes shorter than 2.7 mm, then the valve must be replaced.
- * After installing the valve whose stem end has been ground off as above, check that the face ② of valve stem end is above the valve cotter ③.



VALVE SPRINGS

The force of the two coil springs keeps the valve seat tight. Weakened springs result in reduced engine power output, and often account for the chattering noise coming from the valve mechanism.

Check the valve springs for proper strength by measuring their free lengths and also by the force required to compress them. If the spring length is less than the service limit, or if the force required to compress the spring does not fall within the range specified, replace both the inner and outer springs as a set.

CAUTION:

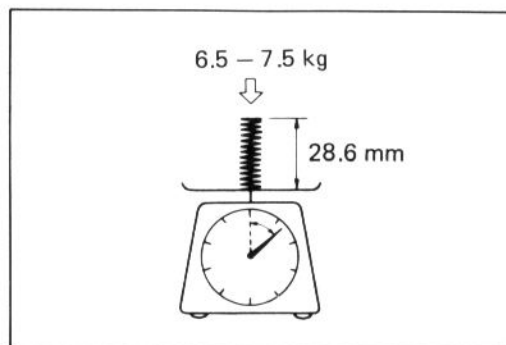
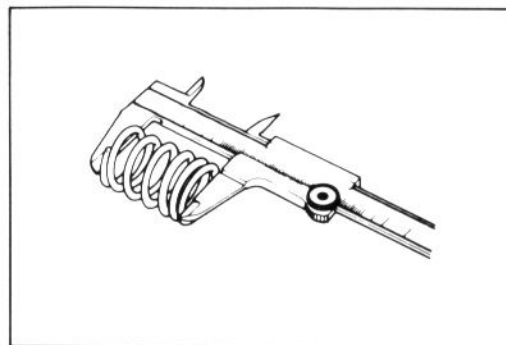
Replace both valve springs, inner and outer, at a time, if any one of these is found to be beyond the limit.

Valve spring free length

Service Limit **INNER : 32.6 mm (1.28 in)**
OUTER: 37.3 mm (1.47 in)

Valve spring tension

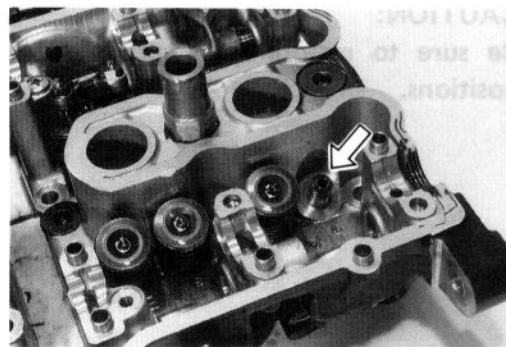
INNER : 6.5 – 7.5 kg/28.6 mm
 Standard (14.3 – 16.5 lbs/1.13 in)
OUTER: 8.8 – 10.2 kg/31.6 mm
 (19.4 – 22.5 lbs/1.24 in)

**REASSEMBLY**

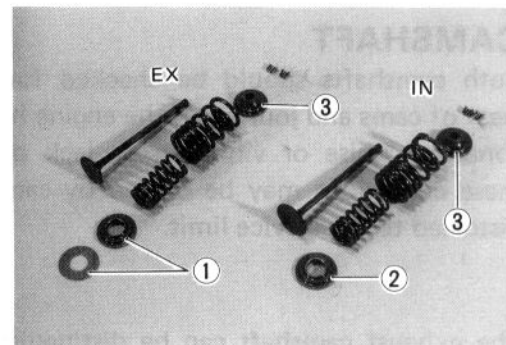
- Oil each oil seal, and press-fit them into position with the finger tip.

CAUTION:

Do not reuse the oil seals.



- Install the valve spring lower seats, ① (for exhaust) and ② (for intake). Be careful not to confuse the lower seat with the spring retainer ③.

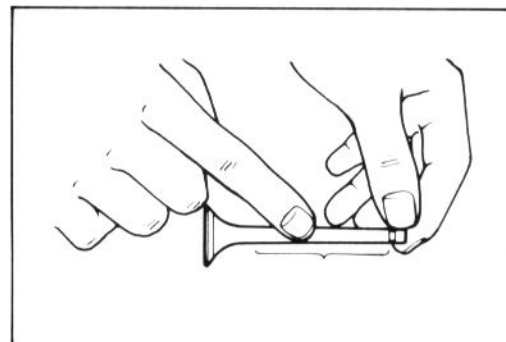


- Insert the valves, with their stems coated with high quality molybdenum disulfide lubricant (SUZUKI MOLY PASTE) all around and along the full stem length without any break.

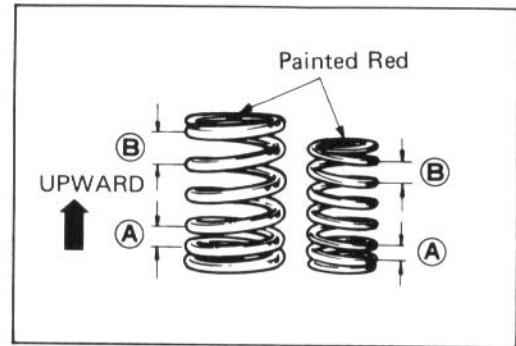
CAUTION:

When inserting each valve, take care not to damage the lip of the stem seal.

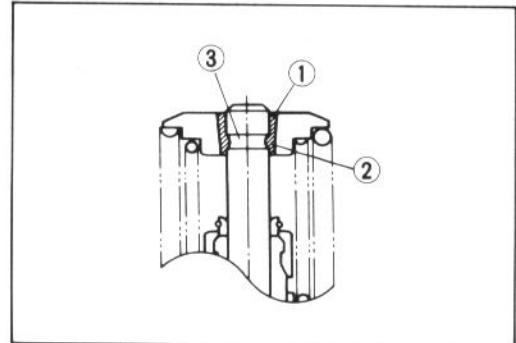
99000-25140: SUZUKI MOLY PASTE



- Install the valve springs with the small-pitch portion (A) facing cylinder head. (B) Large-pitch portion.



- Put on the valve spring retainer and, using the valve lifter, press down the springs, fit the cotter halves to the stem end, and release the lifter to allow the cotter (1) to wedge in between retainer and stem. Be sure that the rounded lip (2) of the cotter fits snugly into the groove (3) in the stem end.



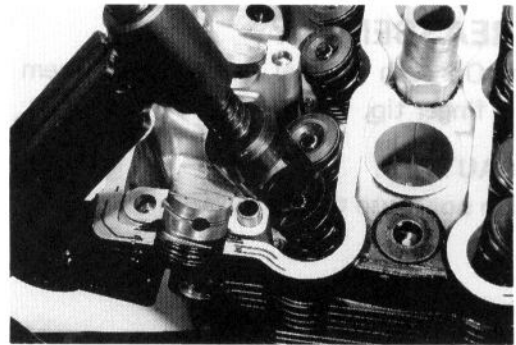
09916-14510: Valve lifter

09916-14910: Valve lifter attachment

09916-84510: Tweezers

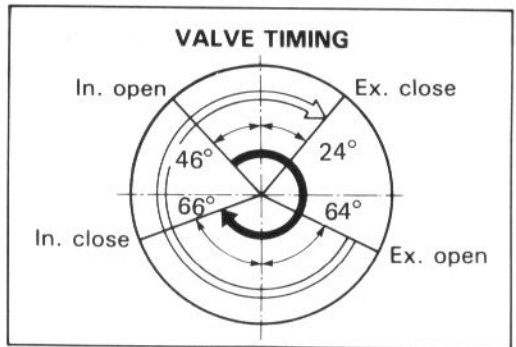
CAUTION:

Be sure to restore each spring and valve to their original positions.



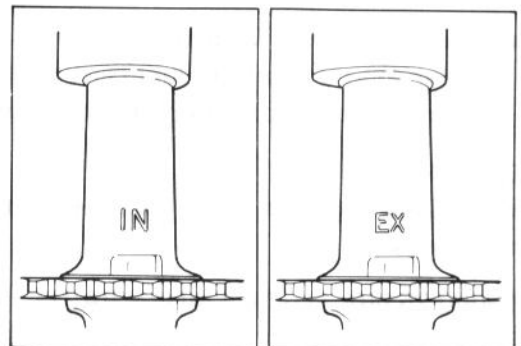
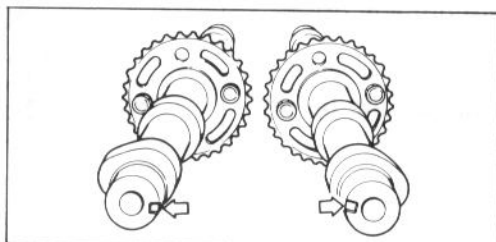
CAMSHAFT

Both camshafts should be checked for runout and also for wear of cams and journals if the engine has been noted as giving abnormal noise or vibration or lack power output. Any of these conditions may be caused by camshafts worn down or distorted to the service limit.



The exhaust camshaft can be distinguished from that of the intake by the embossed letters "EX" (for exhaust) as against letters "IN" (for intake).

Similarly, the right end can be distinguished by the notch from the left end.



CAM WEAR

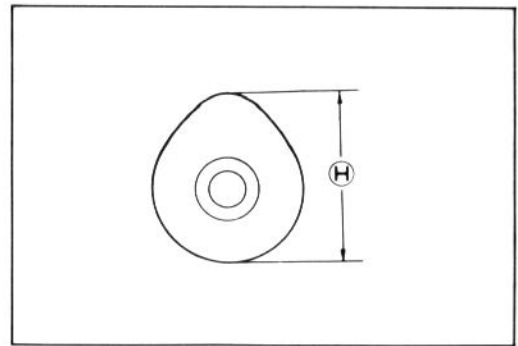
Worn-down cams are often the cause of mistimed valve operation resulting in reduced power output.

The limit of cam wear is specified for both intake and exhaust cams in terms of cam height H , which is to be measured with a micrometer. Replace camshafts if found worn down to the limit.

09900-20202: Micrometer (25 – 50 mm)

Cam height H

Service Limit Intake cams : 32.840 mm (1.2929 in)
Exhaust cams: 32.540 mm (1.2811 in)



CAMSHAFT JOURNAL WEAR

Determine whether or not each journal is worn down to the limit by measuring the oil clearance with the camshaft installed in place. Use plastigauge ① to read the clearance at the widest portion, which is specified as follows:

Camshaft-Journal oil clearance (IN & EX)

Service Limit: 0.150 mm (0.0059 in)

09900-22301: Plastigauge

NOTE:

Install each holder to their original positions. (See page 3-60.)

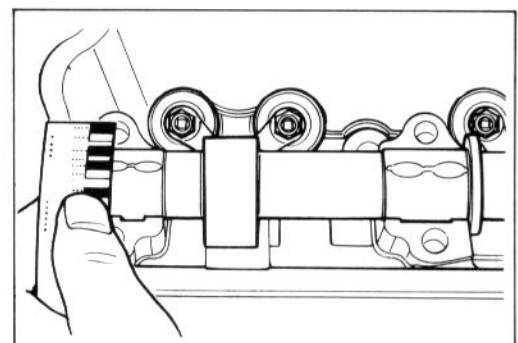
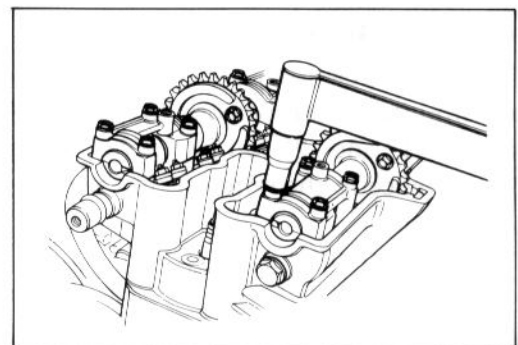
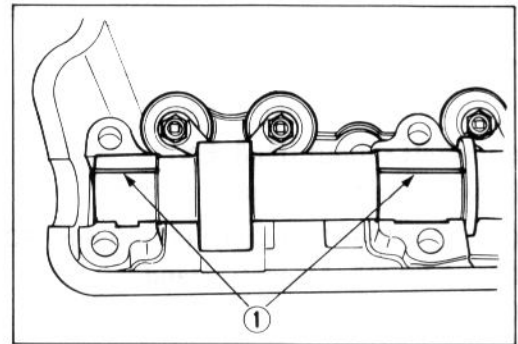
Tighten the camshaft holder bolts evenly and diagonally to the specified torque.

Tightening torque: 8 – 12 N·m
(0.8 – 1.2 kg·m, 6.0 – 8.5 lb·ft)

NOTE:

Do not rotate the camshafts with plastigauge in place.

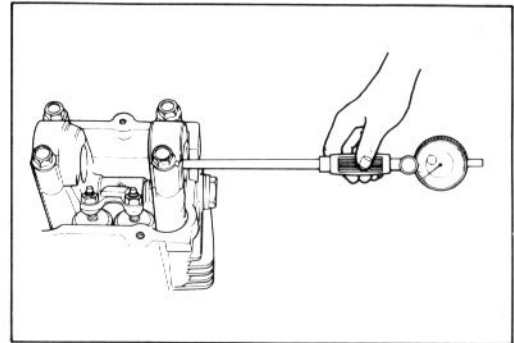
Remove the camshaft holders, and read the width of compressed plastigauge with envelope scale. This measurement should be taken at the widest part.



If the camshaft journal oil clearance measured exceed the limit, measure the inside diameter of camshaft journal holder and outside diameter of the camshaft journal. Replace the camshaft or cylinder head depending upon which one exceeds the specification.

Standard

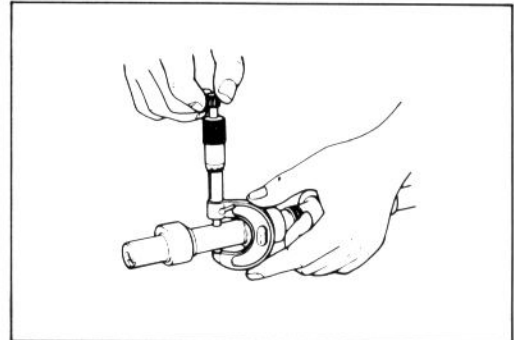
Journal holder I.D. (IN & EX): 22.012 – 22.025 mm
(0.8666 – 0.8671 in)



09900-20205: Micrometer (0 – 25 mm)

Standard

Camshaft journal O.D. (IN & EX): 21.959 – 21.980 mm
(0.8645 – 0.8654 in)

**CAMSHAFT RUNOUT**

Measure the runout with a dial gauge. Replace the camshaft if the runout exceeds the limit.

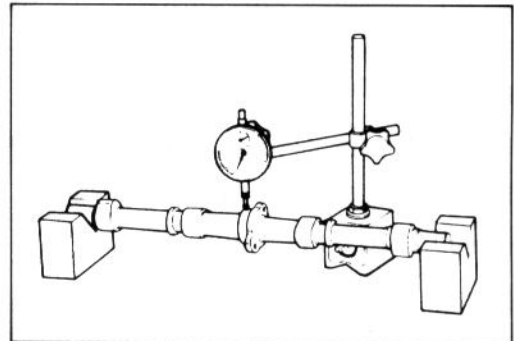
Camshaft runout (IN & EX)

Service Limit: 0.1 mm (0.004 in)

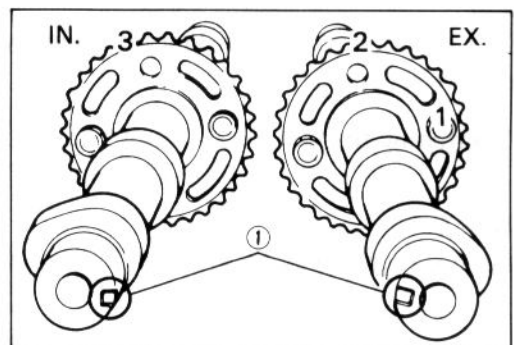
09900-20606: Dial gauge (1/100 mm, 10 mm)

09900-20701: Magnetic stand

09900-21304: V-block (100 mm)

**CAM SPROCKET**

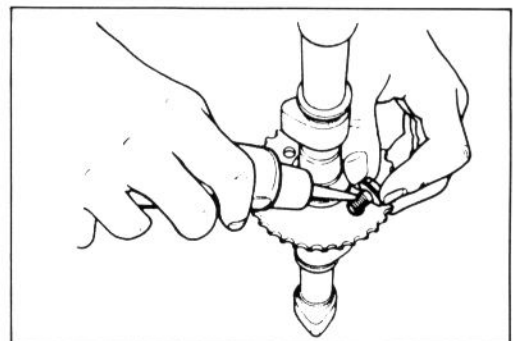
The fixed position of each cam sprocket on each camshaft is determined by arrow mark "3" (on INTAKE sprocket) or arrow marks "1" and "2" (on EXHAUST sprocket) located (as shown) in reference to the notch ① in the right end of each camshaft.

**REASSEMBLY**

- Apply THREAD LOCK SUPER "1303" to the threads of cam sprocket bolts, and tighten them to the following torque value:

99000-32030: THREAD LOCK SUPER "1303"

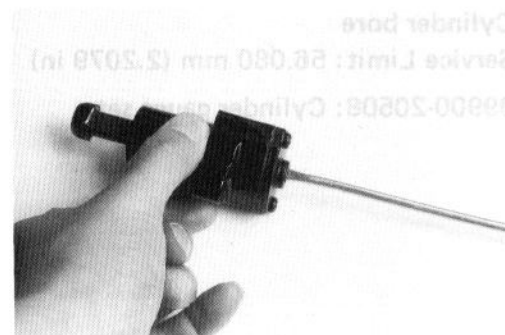
Tightening torque: 24 – 26 N·m
(2.4 – 2.6 kg·m, 17.5 – 19.0 lb·ft)



CAM CHAIN TENSIONER

The cam chain is maintained at the proper tension by an automatically adjusted tensioner.

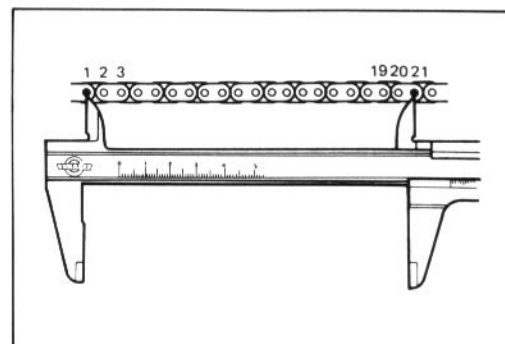
Insert the ⊖ screwdriver into the slotted end of cam chain tensioner and turn the ⊖ screwdriver clockwise to lessen the tension and release the ⊖ screwdriver from the cam chain tensioner, to make sure the push rod movement. If the push rod is stuck or spring mechanism failed, replace the cam chain tensioner assembly with a new one.



CAM CHAIN 20-PITCH LENGTH

Pull the chain tight to remove any slack, then using vernier calipers, measure the 20-pitch length of cam chain. If it measures more than the limit, replace the cam chain.

Service Limit: 143.0 mm (5.63 in)

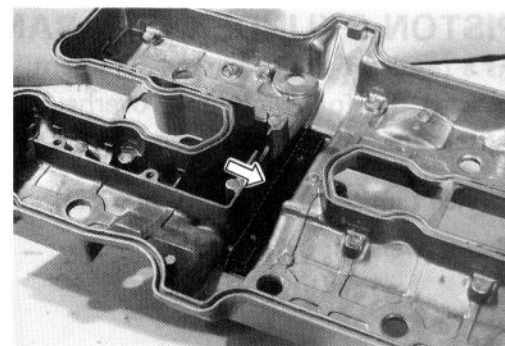


CAM CHAIN GUIDE

NOTE:

When replacing the cam chain guide, apply **SUZUKI THREAD LOCK SUPER "1303"** to threads of screw.

99000-32030: THREAD LOCK SUPER "1303"



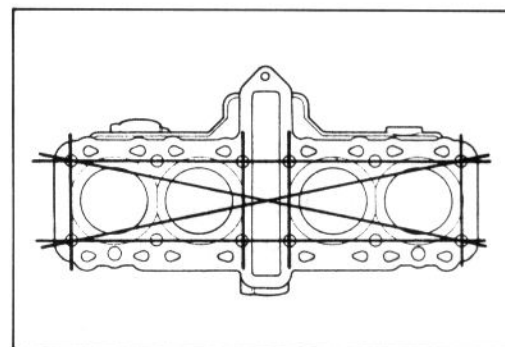
CYLINDER DISTORTION

Check the gasketed surface of the cylinder for distortion with a straightedge and thickness gauge, taking a clearance reading at several places as indicated. If the largest reading at any position of the straightedge exceeds the limit, replace the cylinder.

09900-20803: Thickness gauge

Cylinder distortion specification

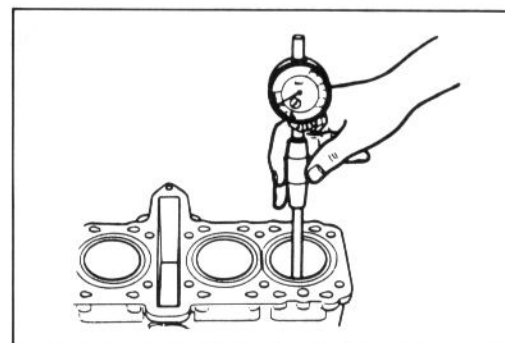
Service Limit: 0.2 mm (0.008 in)



CYLINDER BORE

Measure the cylinder bore diameter at six places. If any one of the measurements exceeds the limit, overhaul the cylinder and replace the piston with an oversize, or replace the cylinder. Once the remaining cylinders must be also rebored accordingly. Otherwise, the imbalance might cause excess vibration.

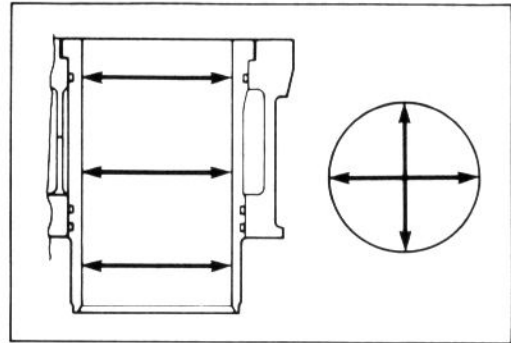
(Continued on next page.)



Cylinder bore

Service Limit : 56.080 mm (2.2079 in)

09900-20508: Cylinder gauge set

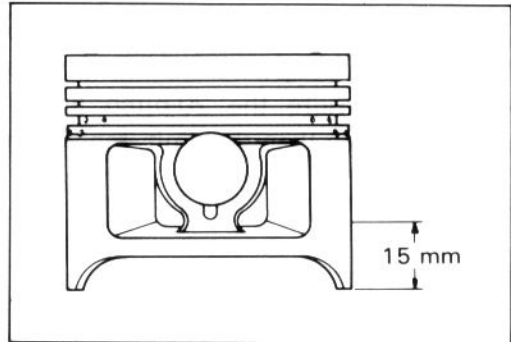


PISTON DIAMETER

Using a micrometer, measure the piston outside diameter at the place shown in Fig. If the measurement is less than the limit, replace the piston.

Service Limit : 55.880 mm (2.2000 in)

09900-20203: Micrometer (50 – 75 mm)

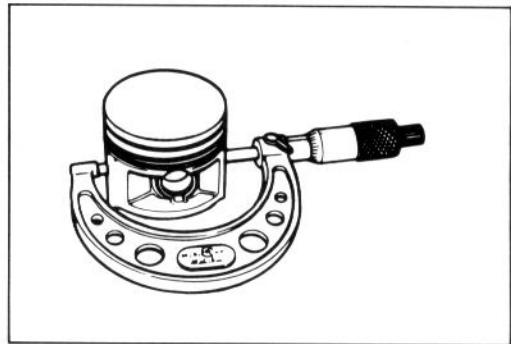


PISTON-CYLINDER CLEARANCE

As a result of the above measurement, if the piston clearance exceeds the following limit, overhaul the cylinder and use an oversize piston, or replace both cylinder and piston.

Service Limit : 0.12 mm (0.0047 in)

Piston oversize: 0.5, 1.0 mm



PISTON RING-GROOVE CLEARANCE

Using a thickness gauge, measure the side clearances of the 1st and 2nd rings. If any of the clearances exceeds the limit, replace both piston and piston rings.

09900-20803: Thickness gauge

Piston ring-groove clearance

Service Limit 1st : 0.18 mm (0.007 in)

2nd: 0.15 mm (0.006 in)

Piston ring groove width

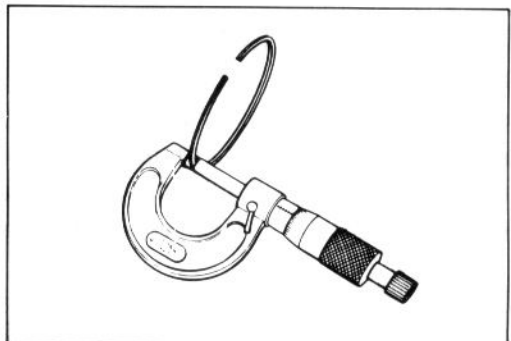
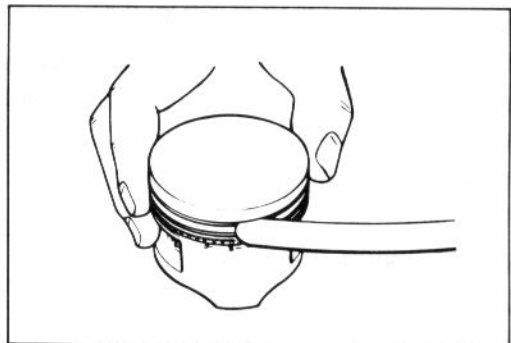
Standard 1st & 2nd: 0.81 – 0.83 mm (0.032 – 0.033 in)

Oil : 1.51 – 1.53 mm (0.059 – 0.060 in)

Piston ring thickness

Standard

1st & 2nd: 0.77 – 0.79 mm (0.030 – 0.031 in)



PISTON RING FREE END GAP AND PISTON RING END GAP

Before installing piston rings, measure the free end gap of each ring using vernier calipers. Next, fit the ring in the cylinder, and measure each ring end gap using a thickness gauge.

If any ring has an excess end gap, replace the ring.

Piston ring free end gap

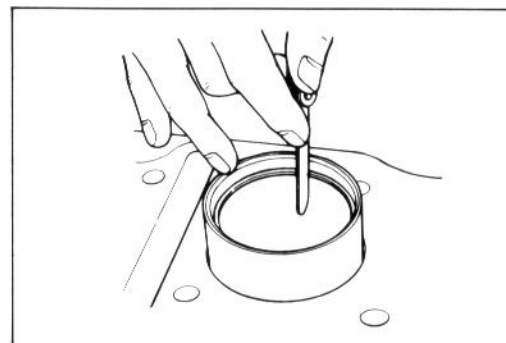
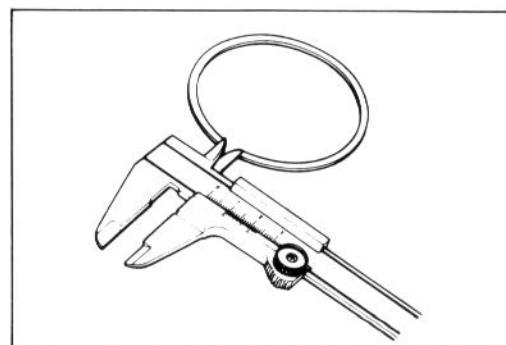
Service Limit 1st : 4.5 mm (0.18 in)
2nd: 4.6 mm (0.18 in)

09900-20102: Vernier calipers

Piston ring end gap

Service Limit
1st & 2nd: 0.5 mm (0.02 in)

09900-20803: Thickness gauge



Oversize piston ring

The following two types of oversize piston rings are used. They bear the following identification numbers.

SIZE	1st	2nd
0.4 mm O.S.	40	40
1.0 mm O.S.	100	100

Oversize oil ring

The following two types of oversize oil rings are available as optional parts. They bear the following identification marks.

SIZE	COLOR
STD	NIL
0.4 mm O.S.	Painted pink
1.0 mm O.S.	Painted yellow

Oversize side rail

Just measure out side diameter to identify the size.

PISTON PIN AND PIN BORE

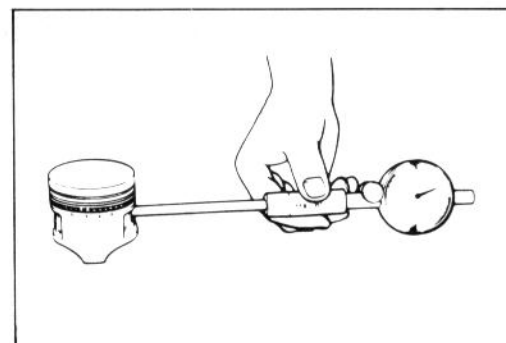
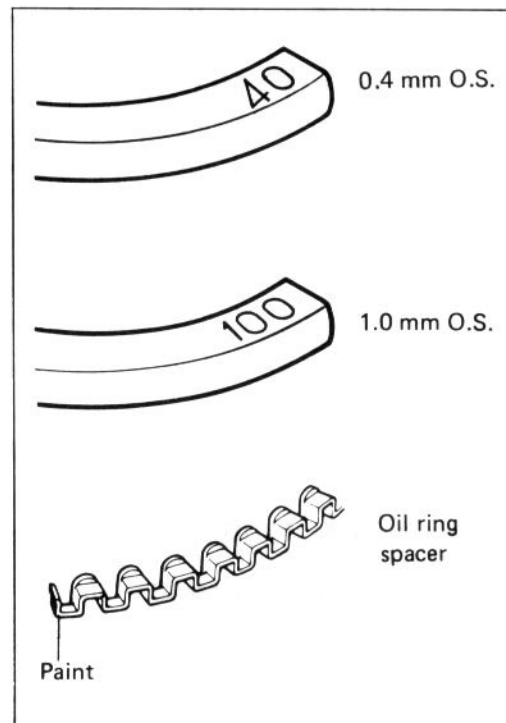
Using a small bore gauge, measure the piston pin bore inside diameter, and using a micrometer, measure the piston pin outside diameter. If the difference between these two measurements is more than the limits, replace both piston and piston pin.

Piston pin bore I.D.

Service Limit: 16.030 mm (0.6311 in)

09900-20602: Dial gauge (1/1000 mm, 1 mm)

09900-22401: Small bore gauge (10 – 18 mm)

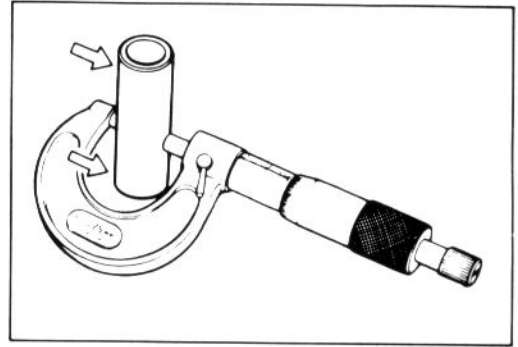


Using a micrometer, measure the piston pin outside diameter at three positions.

Piston pin O.D.

Service Limit: 15.980 mm (0.6291 in)

09900-20205: Micrometer (0 – 25 mm)



CONROD SMALL END I.D.

Using a small bore gauge, measure the conrod small end inside diameter.

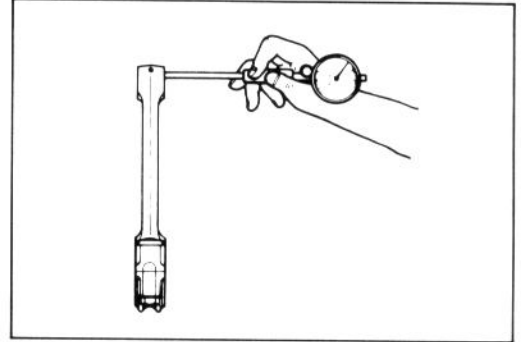
09900-20602: Dial gauge (1/1000 mm, 1 mm)

09900-22401: Small bore gauge (10 – 18 mm)

Conrod small end I.D.

Service Limit: 16.040 mm (0.6315 in)

If the conrod small end inside diameter exceeds the above-mentioned limit, replace the conrod.

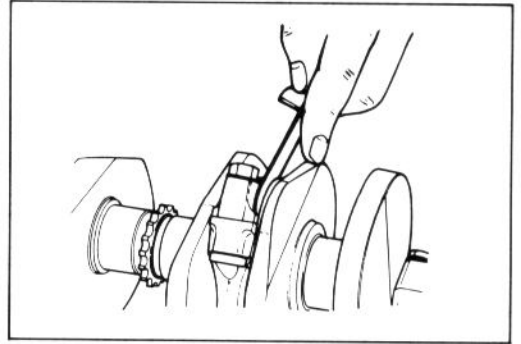


CONROD BIG END SIDE CLEARANCE

Check the conrod side clearance by using a thickness gauge. If the clearance exceeds the limit, replace conrod or crankshaft.

Service Limit: 0.3 mm (0.01 in)

09900-20803: Thickness gauge



Standard

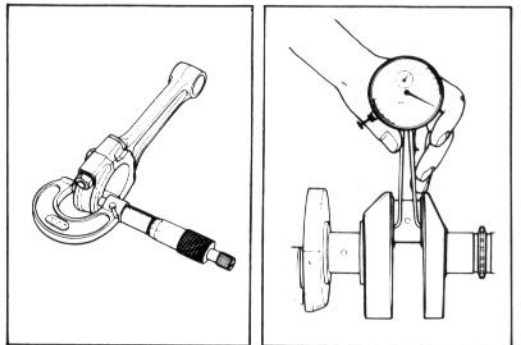
Big end width : 16.95 – 17.00 mm (0.667 – 0.669 in)

Standard

Crank pin width: 17.10 – 17.15 mm (0.673 – 0.675 in)

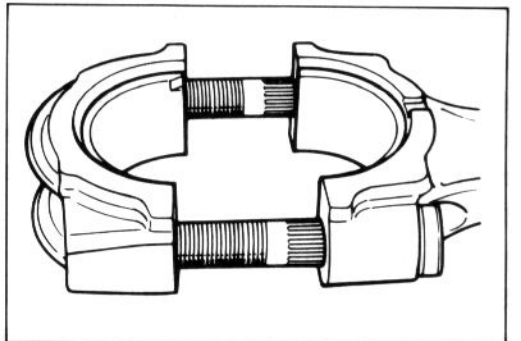
09900-20205: Micrometer (0 – 25 mm)

09900-20605: Dial calipers (10 – 34 mm)



CONROD-CRANK PIN BEARING SELECTION

- Loosen the bearing cap nuts, and tap the bolt end lightly with plastic hammer to remove bearing cap.
- Remove the rods, and mark them to identify the cylinder position.
- Inspect the bearing surfaces for any sign of fusion, pitting, burn, or flaws. If any, replace them with a specified set of bearings.



NOTE:

Never try to remove or loosen the conrod cap bolts due to their possible loosening in the rod. Once displaced, the bearing cap will not be fitted properly.

- Place plastigauge axially on the crank pin avoiding oil hole and at the TDC or BDC side as shown.
- Tighten the bearing cap with two-step to torque values.

Initial tightening torque: 12 – 14 N·m
(1.2 – 1.4 kg·m, 8.5 – 10.0 lb·ft)

Final tightening torque : 28.5 – 31.5 N·m
(2.85 – 3.15 kg·m, 20.5 – 23.0 lb·ft)

09900-22301: Plastigauge**NOTE:**

When fitting bearing cap to crank pin, be sure to discriminate one end from the other, namely front and rear.

NOTE:

Never rotate the crankshaft or conrod when a piece of plastigauge is in the clearance.

- Remove the caps, and measure the width of compressed plastigauge with envelope scale. This measurement should be taken at the widest part.

Crank pin bearing oil clearance

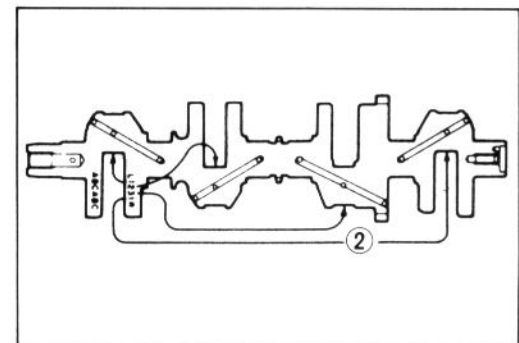
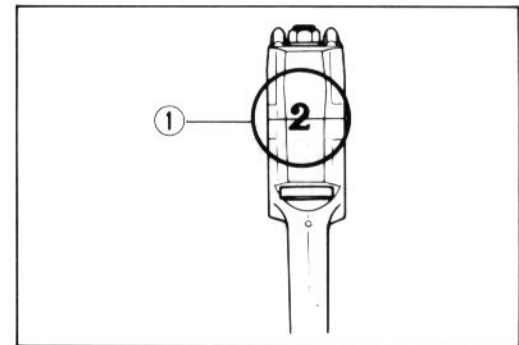
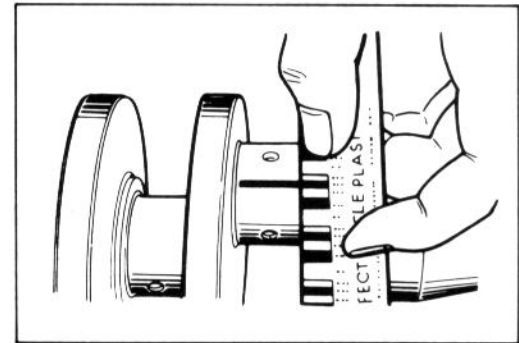
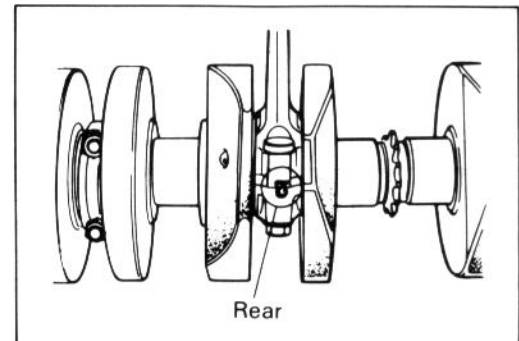
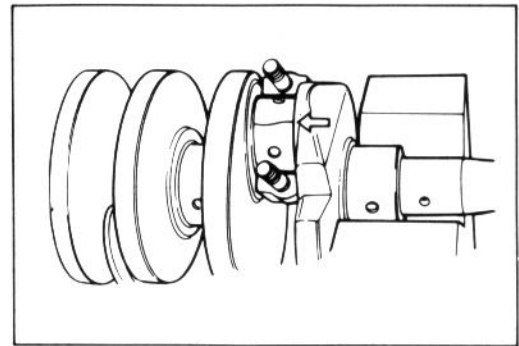
Standard: 0.024 – 0.048 mm (0.0009 – 0.0019 in)

Service Limit: 0.080 mm (0.0031 in)

- If oil clearance exceeds the service limit, select the specified bearings from the following table.
- Check the corresponding rod I.D. code number ①, "1" or "2".
- Check the corresponding crank pin O.D. code number ②, "1", "2" or "3".

Bearing selection table

		Crank pin O.D. ②		
		1	2	3
Conrod I.D. ①	1	Green	Black	Brown
	2	Black	Brown	Yellow

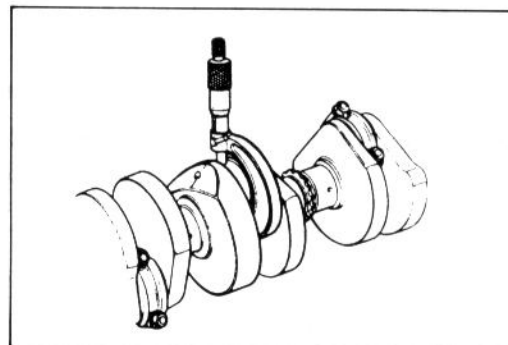


Conrod I.D. specification

Code	I.D. specification
1	33.000 – 33.008 mm (1.2992 – 1.2995 in)
2	33.008 – 33.016 mm (1.2995 – 1.2998 in)

Crank pin O.D. specification

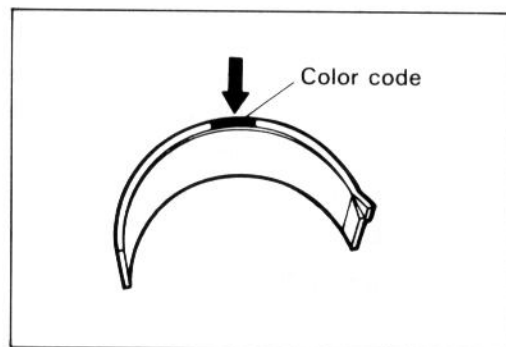
Code	O.D. specification
1	29.992 – 30.000 mm (1.1808 – 1.1811 in)
2	29.984 – 29.992 mm (1.1805 – 1.1808 in)
3	29.976 – 29.984 mm (1.1802 – 1.1805 in)



09900-20202: Micrometer (25 – 50 mm)

Bearing thickness

Color (Part No.)	Thickness
Green (12164-04A01-0A0)	1.484 – 1.488 mm (0.0584 – 0.0586 in)
Black (12164-04A01-0B0)	1.488 – 1.492 mm (0.0586 – 0.0587 in)
Brown (12164-04A01-0C0)	1.492 – 1.496 mm (0.0587 – 0.0589 in)
Yellow (12164-04A01-0D0)	1.496 – 1.500 mm (0.0589 – 0.0591 in)

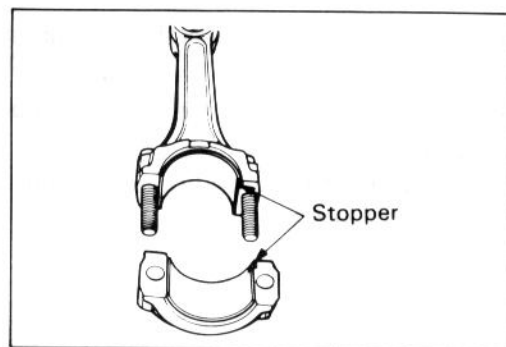


CAUTION:

Bearing should be replaced as a set.

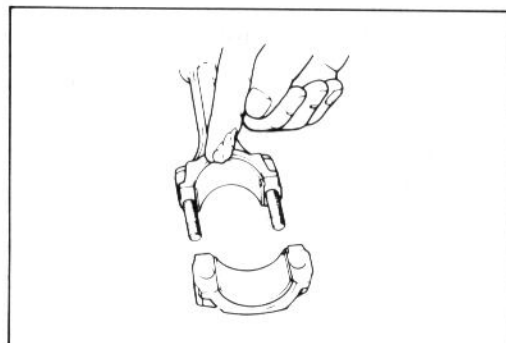
BEARING ASSEMBLY

- When fitting the bearings to the bearing cap and conrod, be sure to fix the stopper part first, and press the other end.



- Apply engine oil or SUZUKI MOLY PASTE to the crank pin and bearing surface.

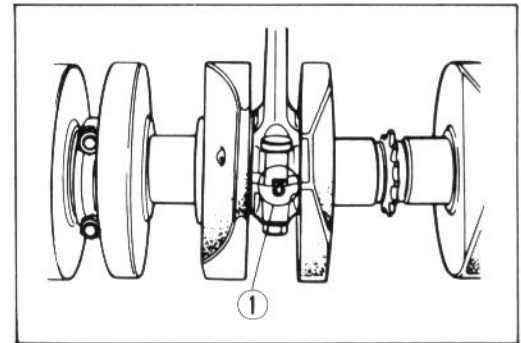
99000-25140: SUZUKI MOLY PASTE



- When mounting the conrod on the crankshaft, make sure that numeral figure ① of the conrod faces rearward.
- Tighten the conrod fitting nuts with specified torque.

Tightening torque: 28.5 – 31.5 N·m
(2.85 – 3.15 kg·m, 20.5 – 23.0 lb-ft)

- Check the conrod movement for smooth turning.



CRANKCASE-CRANKSHAFT BEARING SELECTION

- Inspect each bearing of upper and lower crankcases for any damage.

- Place plastigauge on each crankshaft journal in the usual manner.

09900-22301: Plastigauge

NOTE:

Do not place the plastigauge on the oil hole, and do not rotate the shaft when plastigauge is in place.

- Mate the lower crankcase with the upper crankcase, and tighten the crankshaft tightening bolts with specified torque value in the indicated order.

Tightening torque	Initial Tightening	Final Tightening
8 mm bolt	13 N·m (1.3 kg·m) (9.5 lb-ft)	28 – 32 N·m (2.8 – 3.2 kg·m) (20.0 – 23.0 lb-ft)

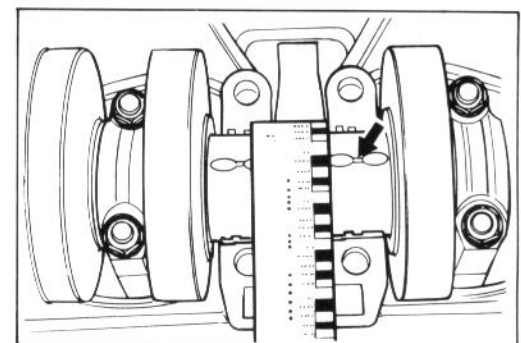
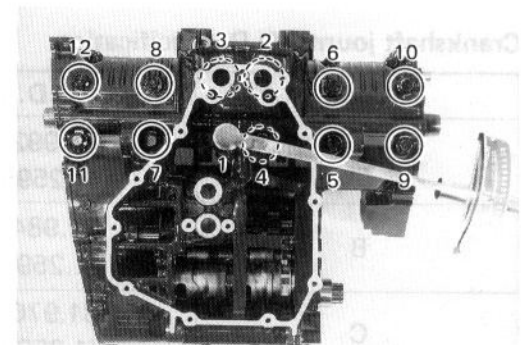
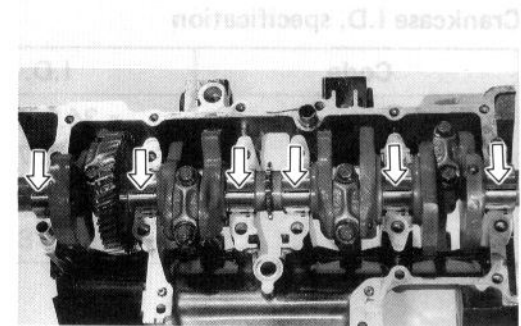
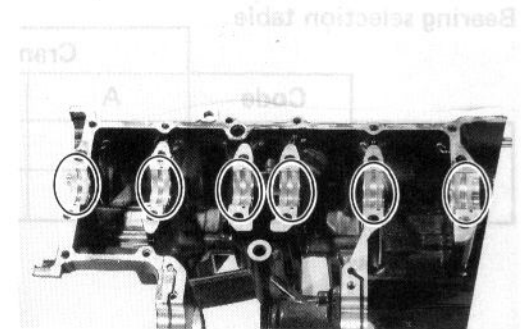
- Remove the lower crankcase, and measure the width of compressed plastigauge in the usual manner.

Crank journal bearing oil clearance

Standard: 0.012 – 0.036 mm (0.0005 – 0.0014 in)

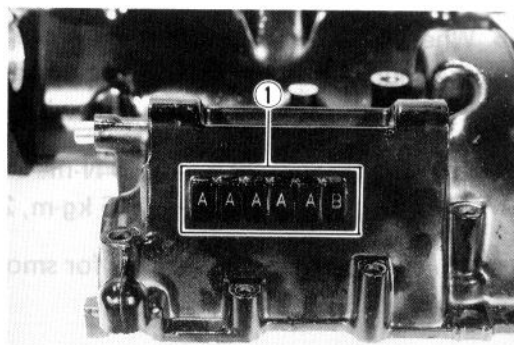
Service Limit: 0.08 mm (0.0031 in)

- If the width at the widest part exceeds the limit, replace the set of bearings with new ones by referring to the selection table.



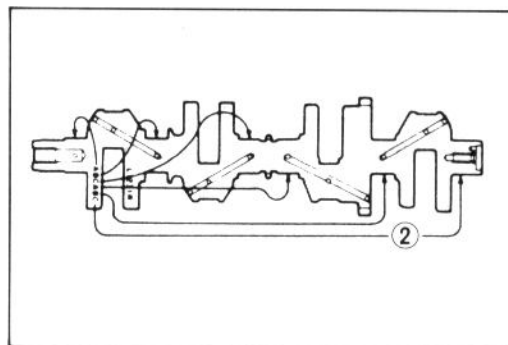
3-37 ENGINE

- Check the corresponding crankcase journal I.D. code number ①, "A" or "B" which are stamped on the rear of upper crankcase.
- Check the corresponding crankshaft journal O.D. code number ②, "A", "B" or "C" which are stamped on the crankshaft.



Bearing selection table

		Crankshaft O.D. ②		
		A	B	C
Crankcase I.D. ①	A	Green	Black	Brown
	B	Black	Brown	Yellow

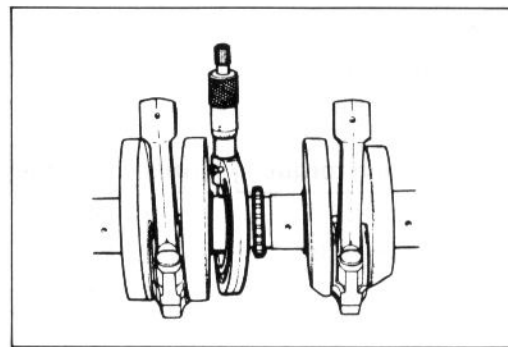


Crankcase I.D. specification

Code	I.D. specification
A	34.992 – 35.000 mm (1.3776 – 1.3780 in)
B	35.000 – 35.008 mm (1.3780 – 1.3783 in)

Crankshaft journal O.D. specification

Code	O.D. specification
A	31.992 – 32.000 mm (1.2595 – 1.2598 in)
B	31.984 – 31.992 mm (1.2592 – 1.2595 in)
C	31.976 – 31.984 mm (1.2589 – 1.2592 in)



09900-20202: Micrometer (25 – 50 mm)

Bearing thickness specification
(Grooved bearing with oil hole . . . For lower case)

Color (Part No.)	Specification
Green (12229-33C00-0A0)	1.486 – 1.490 mm (0.0585 – 0.0587 in)
Black (12229-33C00-0B0)	1.490 – 1.494 mm (0.0587 – 0.0588 in)
Brown (12229-33C00-0C0)	1.494 – 1.498 mm (0.0588 – 0.0590 in)
Yellow (12229-33C00-0D0)	1.498 – 1.502 mm (0.0590 – 0.0591 in)

NOTE:

- * Grooved bearings have the same specification as the Grooved bearing with oil hole.
- * These parts numbers are shown as follows. 12229-30B10-XXX. (Grooved bearing)

CRANKSHAFT THRUST CLEARANCE

- With the crankshaft, right-side thrust bearing and left-side thrust bearing inserted in the upper crankcase, use a thickness gauge to measure the thrust clearance on the left-side.

NOTE:

Push the crankshaft to the starter clutch side, so that there is no clearance on the right-side thrust bearing.

Thrust clearance

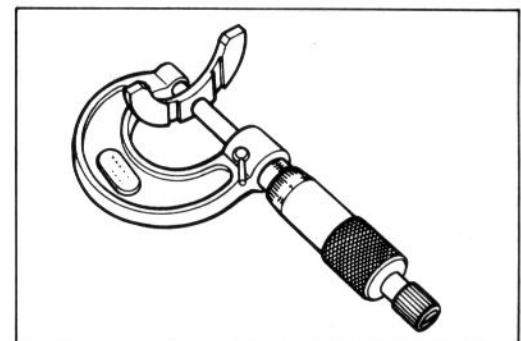
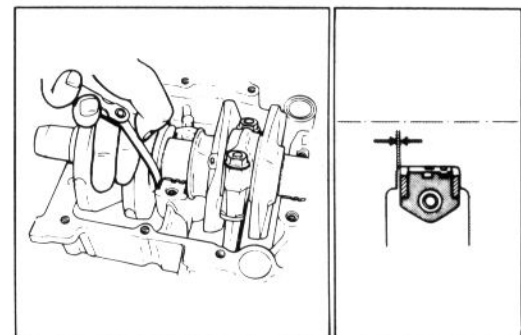
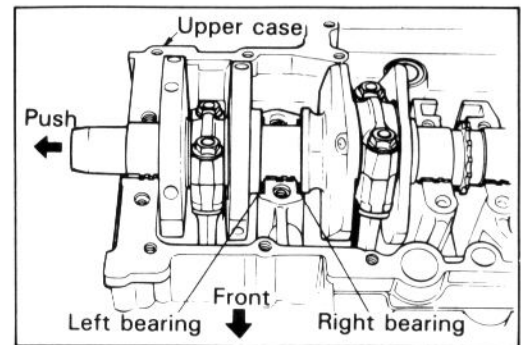
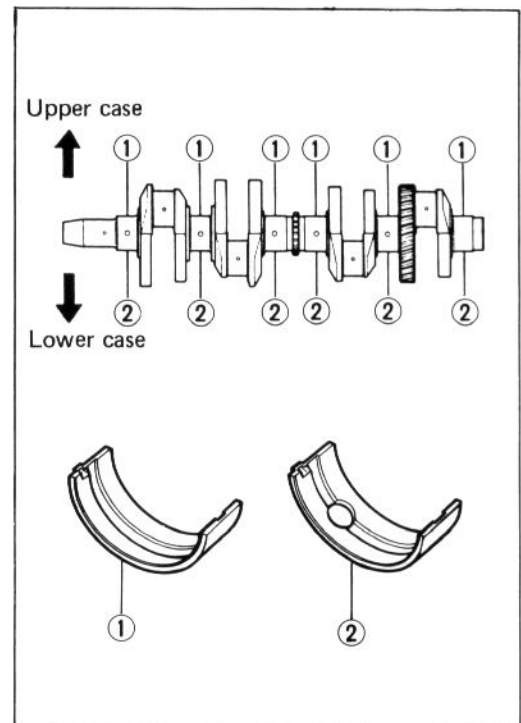
Standard: 0.045 – 0.100 mm (0.0018 – 0.0039 in)

If the thrust clearance exceeds the standard range, adjust the thrust clearance by the following procedures:

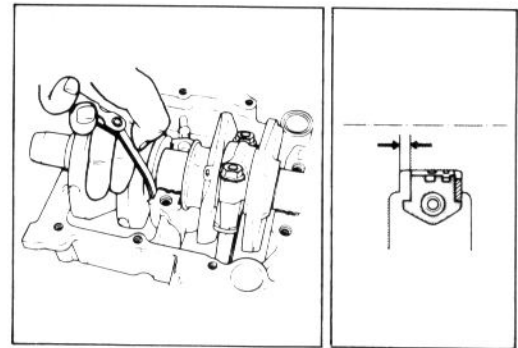
- Remove the right-side thrust bearing and measure its thickness with a micrometer. If the thickness of the right-side thrust bearing is below standard, replace with a new bearing and once again perform the thrust clearance measurement listed above, checking to make sure it is within standard.

Right-side thrust bearing thickness

Standard: 2.425 – 2.450 mm (0.0955 – 0.0965 in)



- If the right-side thrust bearing is within the standard range, reinsert the right-side thrust bearing and remove the left-side thrust bearing.
- As shown in the illustration, use a thickness gauge to measure the clearance before inserting of the left-side thrust bearing, and select a left-side thrust bearing from the selection table.



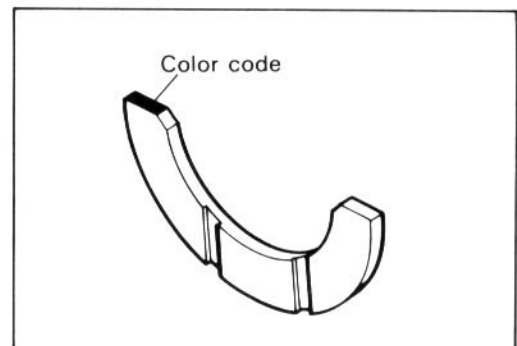
Thrust bearing selection table

Clearance before inserting left-side thrust bearing	Color (Part No.)	Thrust bearing thickness	Thrust clearance
2.420 – 2.445 mm (0.0953 – 0.0963 in)	Red (12228-43411)	2.350 – 2.375 mm (0.0925 – 0.0935 in)	0.045 – 0.095 mm (0.0018 – 0.0037 in)
2.445 – 2.470 mm (0.0963 – 0.0972 in)	Black (12228-43412)	2.375 – 2.400 mm (0.0935 – 0.0945 in)	
2.470 – 2.495 mm (0.0972 – 0.0982 in)	Blue (1.2228-43413)	2.400 – 2.425 mm (0.0945 – 0.0955 in)	
2.495 – 2.520 mm (0.0982 – 0.0992 in)	Green (12228-43414)	2.425 – 2.450 mm (0.0955 – 0.0965 in)	
2.520 – 2.545 mm (0.0992 – 0.1002 in)	Yellow (12228-43415)	2.450 – 2.475 mm (0.0965 – 0.0974 in)	
2.545 – 2.575 mm (0.1002 – 0.1014 in)	White (12228-43416)	2.475 – 2.500 mm (0.0974 – 0.0984 in)	0.045 – 0.100 mm (0.0018 – 0.0039 in)

- After selecting a left-side thrust bearing, insert it and again perform the thrust clearance measurement to make sure it falls within the standard range.

NOTE:

Right-side thrust bearing has the same specification as the GREEN (12228-43414) of left-side thrust bearing.



CRANKSHAFT RUNOUT

Support the crankshaft with "V" blocks as shown, with the two end journals resting on the blocks. Set up the dial gauge, as shown, and rotate the crankshaft slowly to read the runout. Replace the crankshaft if the runout is greater than the limit.

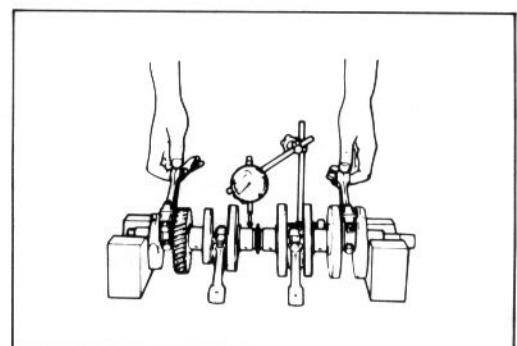
09900-20606: Dial gauge (1/100 mm, 10 mm)

09900-20701: Magnetic stand

09900-21304: V-block (100 mm)

Crankshaft runout

Service Limit: 0.05 mm (0.002 in)



CLUTCH

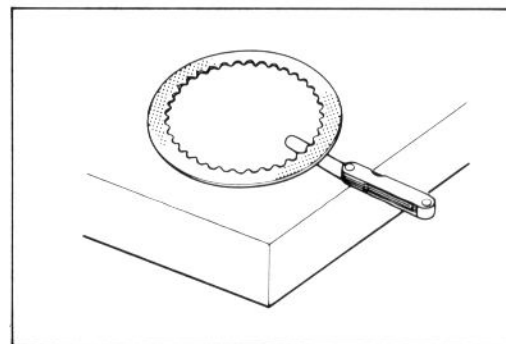
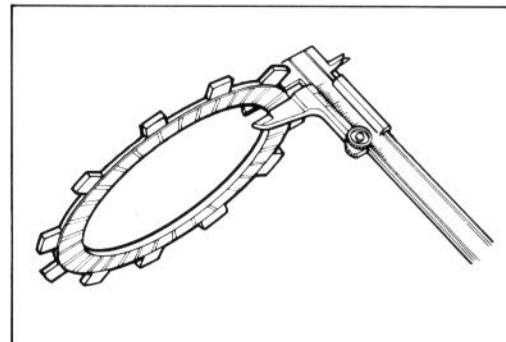
CLUTCH DRIVE AND DRIVEN PLATES

These plates are expendable: they are meant to be replaced when found worn down or distorted to the respective limit: use a vernier calipers to check thickness and a thickness gauge and surface plate to check distortion.

09900-20102: Vernier calipers (200 mm)

09900-20803: Thickness gauge

	Standard	Service Limit
Drive plate thickness	2.90 – 3.10 mm (0.114 – 0.122 in)	2.60 mm (0.102 in)
Drive plate claw width	11.8 – 12.0 mm (0.46 – 0.47 in)	11.0 mm (0.43 in)
Driven plate distortion	–	0.10 mm (0.004 in)

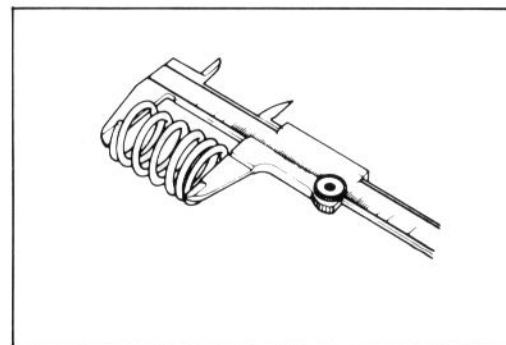


CLUTCH SPRING FREE LENGTH

Measure the free length of each coil spring with vernier calipers, and compare the elastic strength of each with the specific limit. Replace all the springs if any one of springs is not within the limit.

09900-20102: Vernier calipers (200 mm)

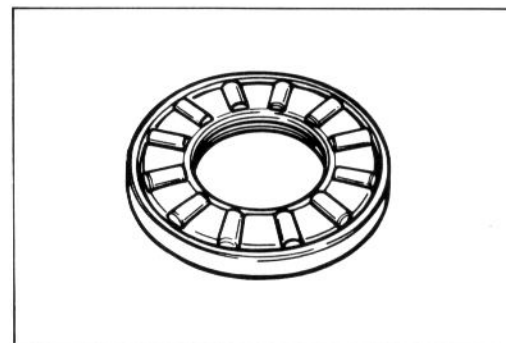
Clutch spring free length	Service Limit
	31.0 mm (1.22 in)



CLUTCH RELEASE BEARING

Inspect the clutch release bearing for any abnormality to decide whether it can be reused or should be replaced.

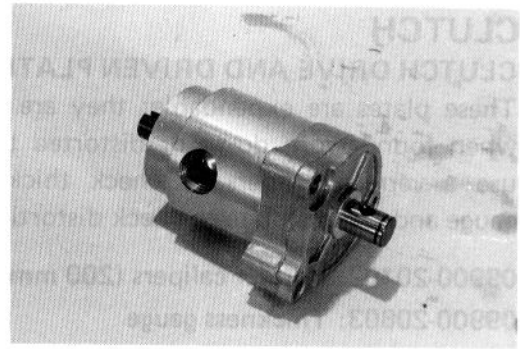
Smooth engagement and disengagement of the clutch depends much on the condition of this bearing.



OIL PUMP

CAUTION:

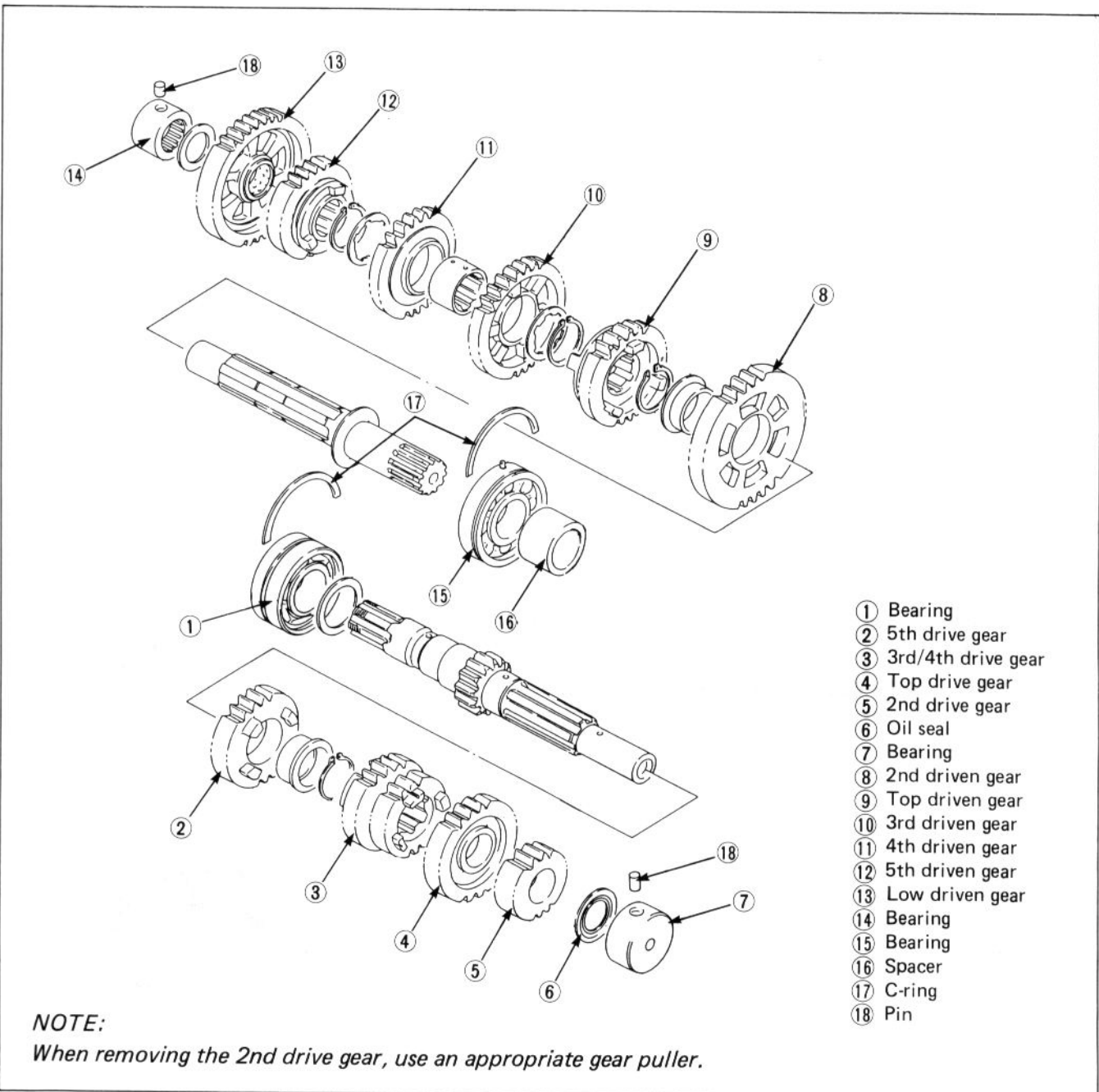
Do not attempt to disassemble the oil pump assembly.
The oil pump is available only as an assembly.



TRANSMISSION

DISASSEMBLY

Disassemble the transmission gears as shown in the illustration.



- ① Bearing
- ② 5th drive gear
- ③ 3rd/4th drive gear
- ④ Top drive gear
- ⑤ 2nd drive gear
- ⑥ Oil seal
- ⑦ Bearing
- ⑧ 2nd driven gear
- ⑨ Top driven gear
- ⑩ 3rd driven gear
- ⑪ 4th driven gear
- ⑫ 5th driven gear
- ⑬ Low driven gear
- ⑭ Bearing
- ⑮ Bearing
- ⑯ Spacer
- ⑰ C-ring
- ⑱ Pin

REASSEMBLY

Assemble the countershaft and driveshaft in the reverse order of disassembly. Pay attention to following points:

NOTE:

- * Before installing the gears, rotate the bearing by hand to inspect for abnormal noise and smooth rotation. If there is any abnormal, replace the bearing with new one.
- * Before installing the gears, coat lightly moly paste or engine oil on the driveshaft and countershaft.

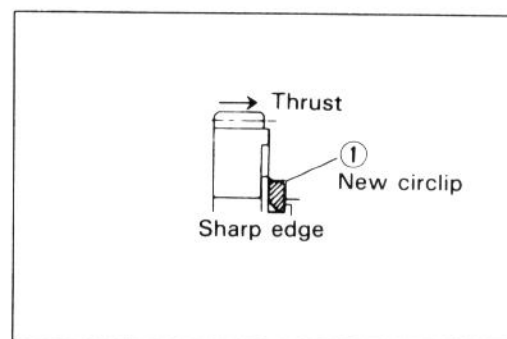
99000-25140 : SUZUKI MOLY PASTE**CAUTION:**

- * **Never reuse a circlip.** After a circlip has been removed from a shaft, it should be discarded and a new circlip must be installed.
- * **When installing a new circlip, care must be taken not to expand the end gap larger than required to slip the circlip over the shaft.**
- * **After installing a circlip, always insure that it is completely seated in its groove and securely fitted.**

NOTE:

In reassembling the transmission gears, attention must be given to the locations and positions of washers and circlips. The cross sectional view given here will serve as a reference for correctly mounting the gears, washers and circlips. (Refer to page 3-43.)

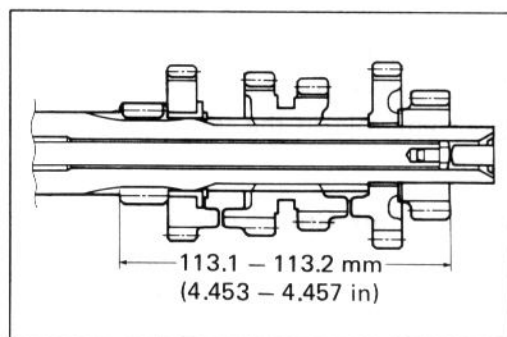
- When installing a new circlip ①, pay attention to the direction of the circlip. Fit it to the side where the thrust is as shown in the illustration.



- Press-fit the 2nd drive gear onto the countershaft.

NOTE:

- * Before reassembling the 2nd drive gear, apply its internal surface with **THREAD LOCK SUPER "1303"** and install it so that the length as shown in the illustration.
- * After installing the 2nd drive gear, check that Top drive gear spins smoothly by moving it with your fingers.
- * This procedure may be performed only twice before shaft replacement is required.

**99000-32030 : THREAD LOCK SUPER "1303"**

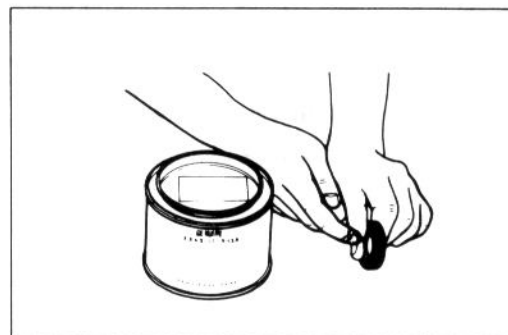
- Apply grease to each oil seal lip and install them onto the driveshaft and countershaft.

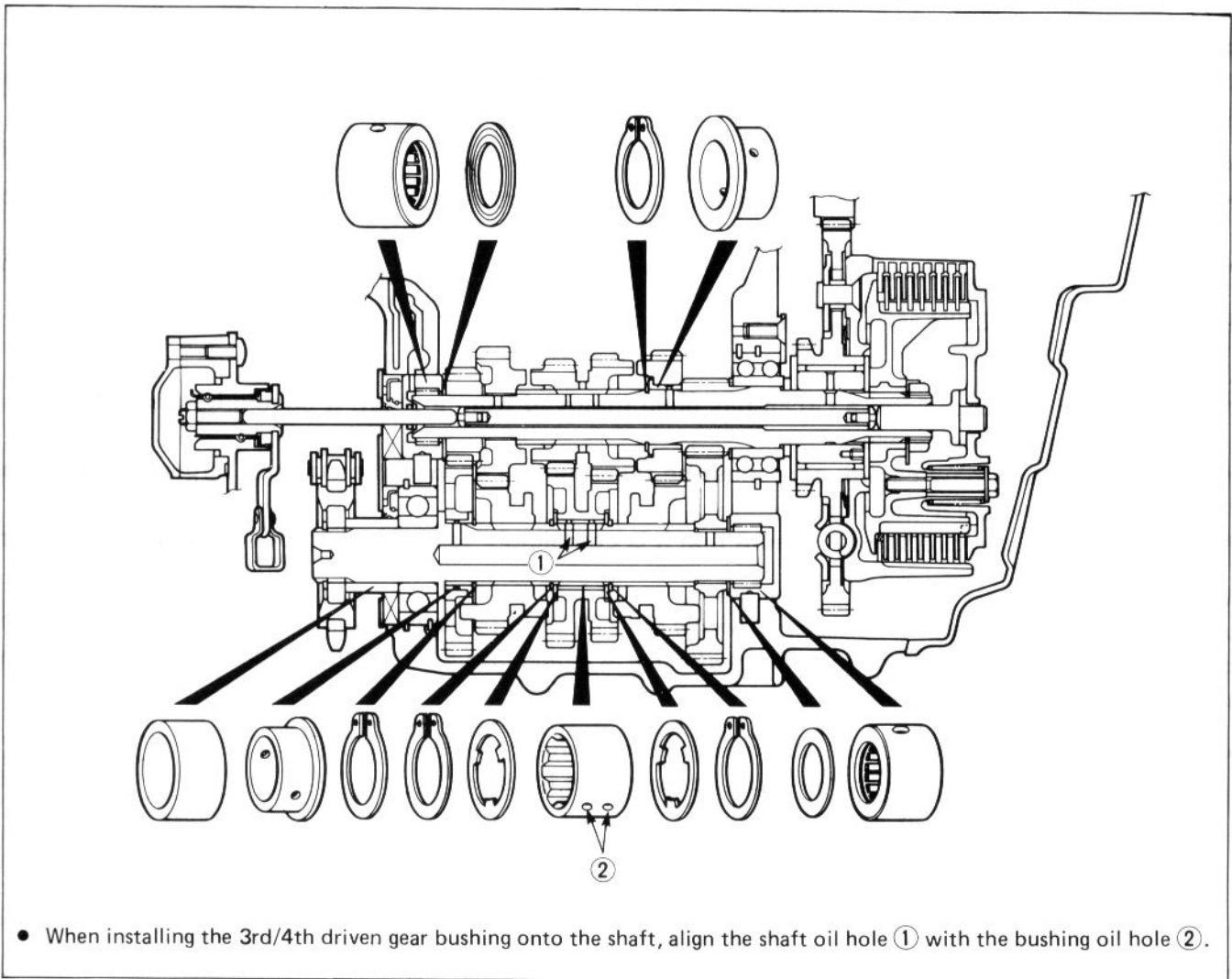
(For U.S.A. model)

99000-25030 : SUZUKI SUPER GREASE "A"

(For the other models)

99000-25010 : SUZUKI SUPER GREASE "A"





GEARSHIFT FORK-GROOVE CLEARANCE

Using a thickness gauge, check the gearshift fork clearance in the groove of its gear.

The clearance for each of the three gearshift forks plays an important role in the smoothness and positiveness of shifting action.

Gearshift fork-Groove clearance

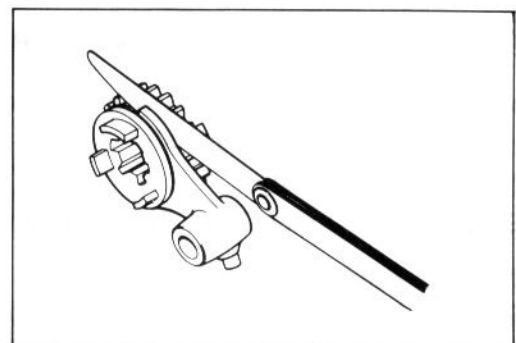
Standard : 0.10 – 0.30 mm (0.004 – 0.012 in)

Service Limit: 0.50 mm (0.020 in)

If the clearance checked is noted to exceed the limit specified, replace the fork or its gear, or both.

09900-20803: Thickness gauge

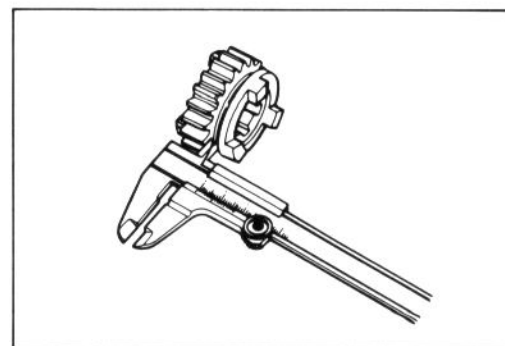
09900-20102: Vernier calipers



Checking clearance

Shift fork groove width**Standard**

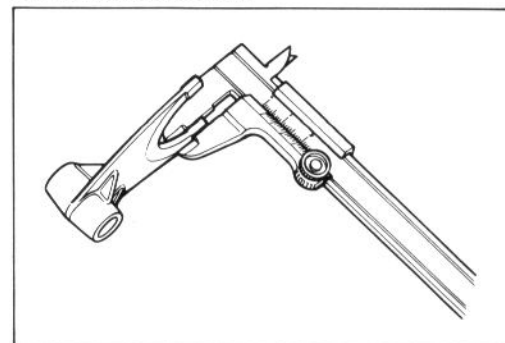
(No. 1, No. 2 & No. 3): 5.50 – 5.60 mm (0.217 – 0.220 in)



Checking groove width

Shift fork thickness**Standard**

(No. 1, No. 2 & No. 3): 5.30 – 5.40 mm (0.209 – 0.213 in)



Checking thickness

ENGINE REASSEMBLY

The engine is reassembled by carrying out the steps of disassembly in the reversed order, but there are a number of steps which demand special descriptions or precautionary measures.

NOTE:

Apply engine oil to each running and sliding part before reassembling.

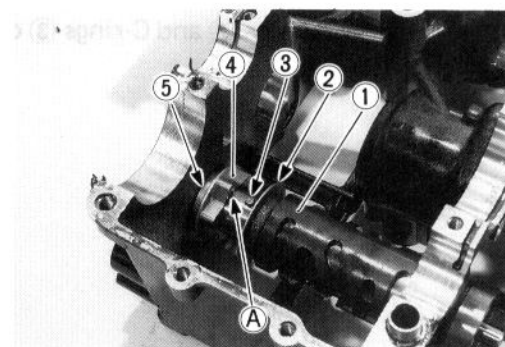
- Install the gearshift cam related parts.

- ① Gearshift cam
- ② Washer
- ③ Pin
- ④ Gearshift cam stopper plate
- ⑤ Spacer

NOTE:

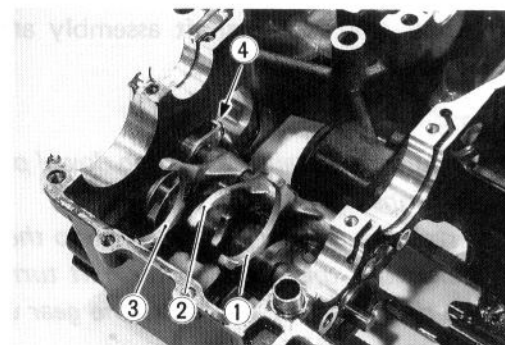
When installing the cam stopper plate ④, align the pin groove

Ⓐ with the pin ③ as shown in the Fig.



- Install the gearshift forks to the crankcase in the correct positions and directions.

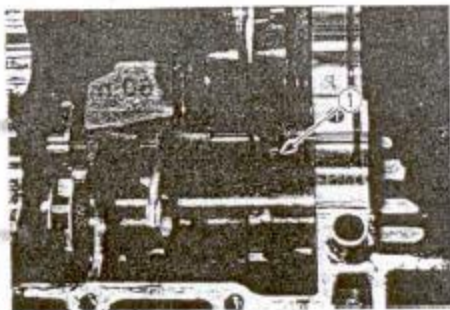
- ① For 5th driven gear (No. 1)
- ② For 3rd/4th drive gear (No. 3)
- ③ For Top driven gear (No. 2)
- ④ Gearshift cam stopper



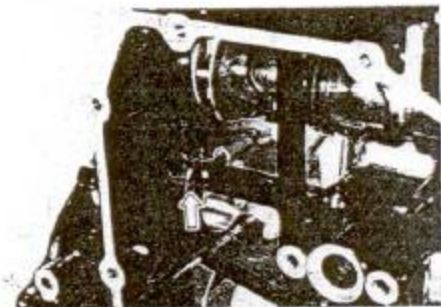
- Installare il rullo ① sulla forcella del cambio No.1.

NOTA:

Posizionare il selettore a camma in folle in modo che le forcelle e il cambio possano essere installati facilmente.



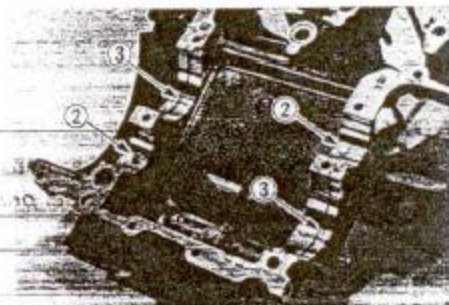
- Agganciare la molla di arresto del selettore a camma sul carter.



- Controllare che i getti dell'olio ① inseriti sul carter superiore non siano intasati.



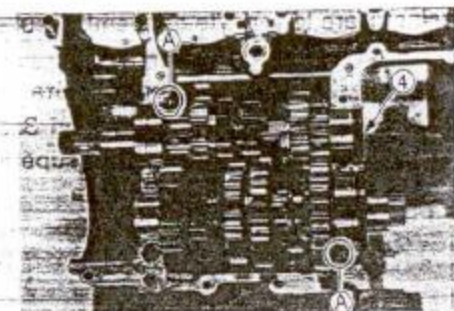
- Inserire i perni dei cuscinetti ② e gli anelli a C ③ nel carter superiore.



- Installare il gruppo dell'albero secondario e quello dell'albero primario sul carter superiore.

NOTA:

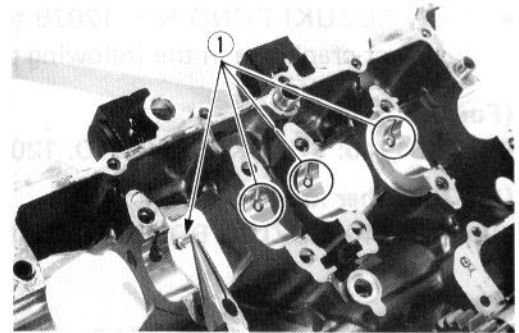
- Accertarsi di installare le spine di centraggio dei cuscinetti A nelle posizioni rispettive.
- Installare il tappo dell'estremità dell'albero secondario nella posizione ④.
- Accertarsi che l'albero secondario ruoti liberamente tenendo fermo l'albero principale. Se ciò non fosse, portare la marcia ingranata nella posizione di folle.



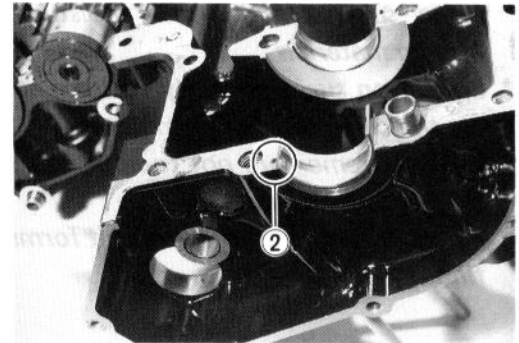
NOTE:

Before fitting the crankshaft journal bearings, check the nozzles ① fitted on the upper crankcase for clogging.

- ① Nozzle (4 pcs) For upper case



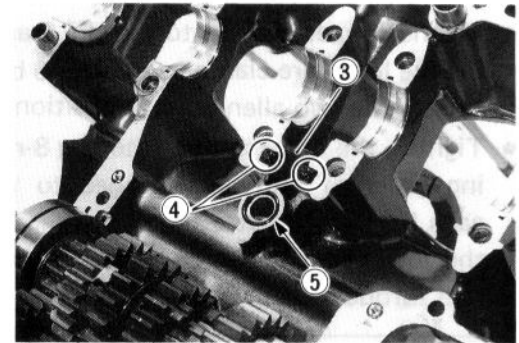
- When fitting the crankshaft journal bearings to the upper and lower crankcases, be sure to fix the stopper part ② first and press the other end. (Refer to page 3-38.)



CAUTION:

Do not touch the bearing surfaces with your hands. Grasp by the edge of the bearing shell.

- Install the cam chain guide ③ and two dampers ④ properly.
- Fit the O-ring ⑤.



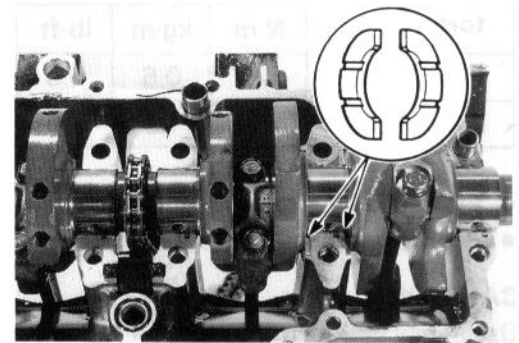
CAUTION:

Replace the O-ring with a new one to prevent oil leakage.

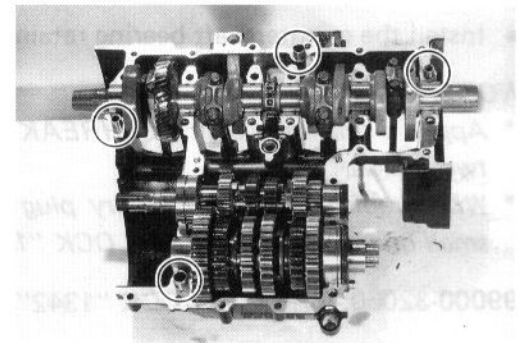
- Before installing the crankshaft, apply SUZUKI MOLY PASTE to each journal bearing lightly.

99000-25140: SUZUKI MOLY PASTE

- Install the crankshaft with the cam chain to the upper crankcase.
- Insert the right and left-thrust bearings with oil grooved facing the crank web. (Refer to page 3-38.)



- Clean the mating surfaces of the crankcases before matching the upper and lower ones.
- Install the dowel pins to the upper crankcase.



- Apply SUZUKI BOND NO. 1207B to the mating surface of the lower crankcase in the following procedure.

(For U.S.A. model)

99104-31140: SUZUKI BOND NO. 1207B

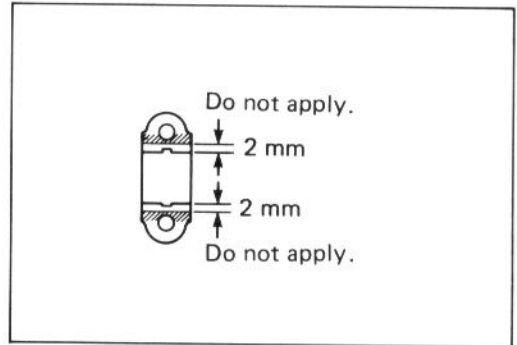
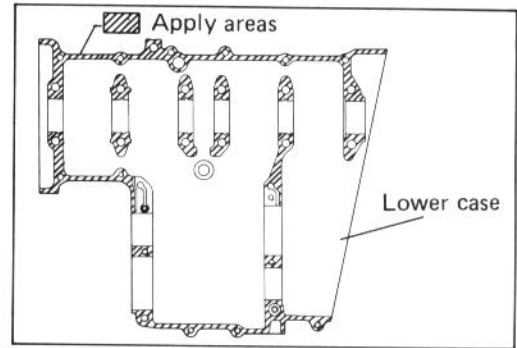
(For the other models)

99000-31140: SUZUKI BOND NO. 1207B

NOTE:

Use of SUZUKI BOND NO. 1207B is as follows:

- * Make surfaces free from moisture, oil, dust and other foreign materials.
- * Spread on surfaces thinly to form an even layer, and assemble the cases within few minutes.
- * Take extreme care not to apply and BOND NO. 1207B to the bearing surfaces.
- * Apply to cornered surface as it forms a comparatively thick film.



- Fit the copper washers to the No. 9 and No. 11 bolts.
- Fit the lead wire clamp to the No. 6 bolt.
- Locate the two allen bolts at position (A).
- Tighten the crankshaft tightening 8-mm bolts in the ascending order of numbers assigned to these bolts, tightening each bolt a little at a time to equalize the pressure. Tighten the lower and upper crankcase securing bolts to the specified torque values.

Tightening torque	Initial tightening			Final tightening		
	N·m	kg-m	lb-ft	N·m	kg-m	lb-ft
6 mm bolt	6	0.6	4.5	13	1.3	9.5
8 mm bolt	13	1.3	9.5	32	3.2	23.0

- Fit the lead wire clamps (B) to the correct position as shown.
- Fit the gaskets (C) to the correct positions as shown.

CAUTION:

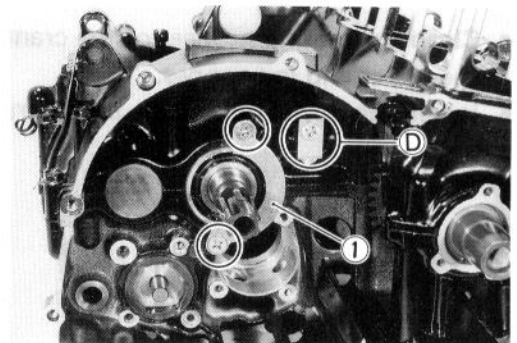
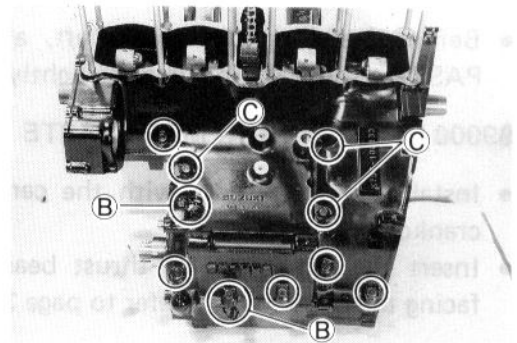
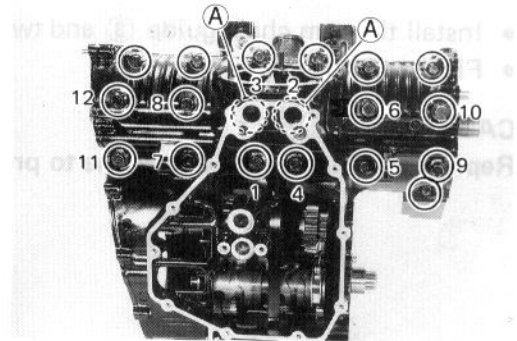
Use a new gasket to prevent oil leakage.

- Install the countershaft bearing retainer with two screws.

NOTE:

- * Apply a small quantity of THREAK LOCK "1342" to the two screws.
- * When replacing the oil gallery plug retainer (D), apply a small quantity of THREAD LOCK "1342" to its screw.

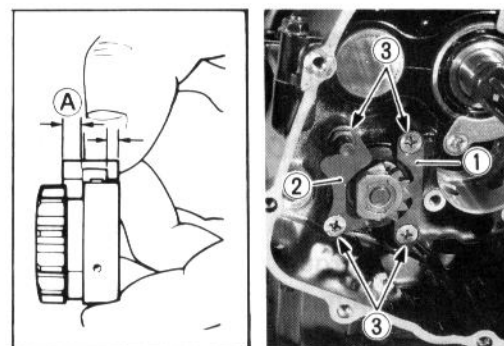
99000-32050: THREAD LOCK "1342"



- Install each gear shifting pawl into the cam driven gear. The large shoulder **A** must face to the outside as shown.
- When installing the cam guide **1** and pawl lifter **2**, apply a small quantity of THREAD LOCK "1342" to the screws **3**.

99000-32050: THREAD LOCK "1342"

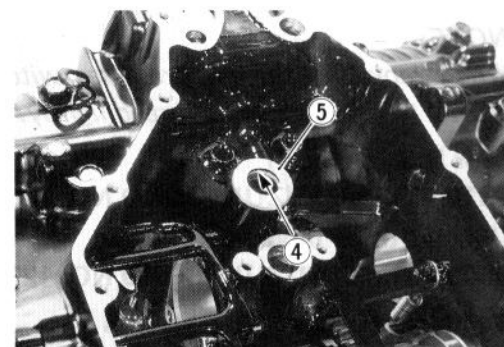
09900-09003: Impact driver set



- Fit a new O-ring **4** and shim **5**.

CAUTION:

Use a new O-ring to prevent oil leakage.



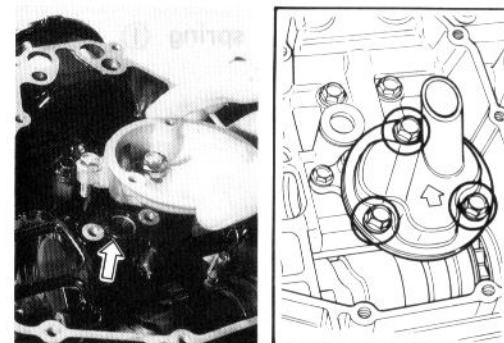
- Fit a new O-ring, then install the oil sump filter guide and oil sump filter.

NOTE:

Be sure to face the arrow mark on the oil sump filter guide and oil sump filter to the front side.

CAUTION:

Use a new O-ring to prevent oil leakage.



- Seat the washer and install the oil pressure regulator **1** to the oil pan.
- Tighten the oil pressure regulator to the specified torque.

Tightening torque: 25 – 30 N·m

(2.5 – 3.0 kg-m, 18.0 – 21.5 lb-ft)



- Fit a new gasket and install the oil pan with bolts. Tighten the oil pan bolts to the specified torque.

Tightening torque: 6 – 10 N·m

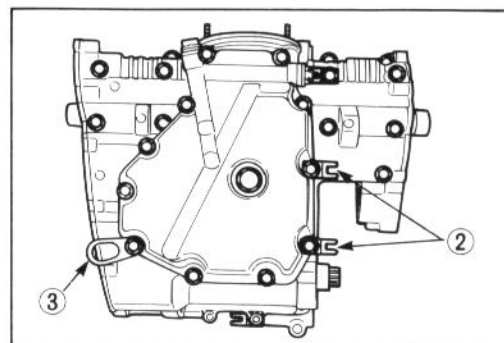
(0.6 – 1.0 kg-m, 4.5 – 7.0 lb-ft)

NOTE:

*Fit the lead wire clamps **2** and air cleaner water drain hose guide **3** to the correct positions as shown.*

CAUTION:

Use a new gasket to prevent oil leakage.



- Apply grease lightly to the O-ring ①.
- Install the oil filter and its cap.

NOTE:

Be sure that the O-ring ① and spring ② are installed correctly.

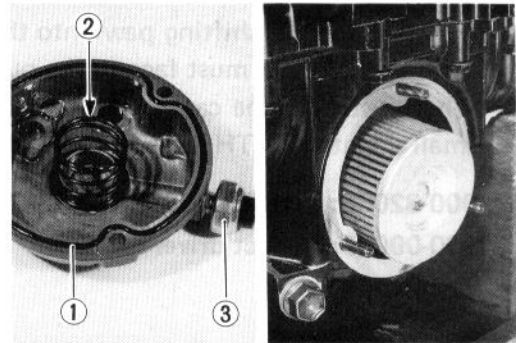
CAUTION:

Replace the O-ring ① with a new one.

Tightening torque

Oil filter cap nut: 12 – 16 N·m

(1.2 – 1.6 kg·m, 8.5 – 11.5 lb-ft)



NOTE:

When replacing the oil pressure switch ③, apply SUZUKI BOND NO. 1207B to its thread lightly.

(For U.S.A. model)

99104-31140: SUZUKI BOND NO. 1207B

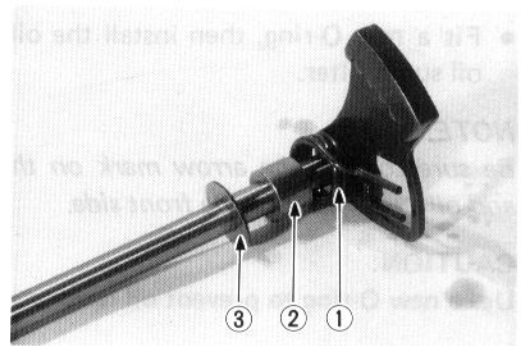
(For the other models)

99000-31140: SUZUKI BOND NO. 1207B

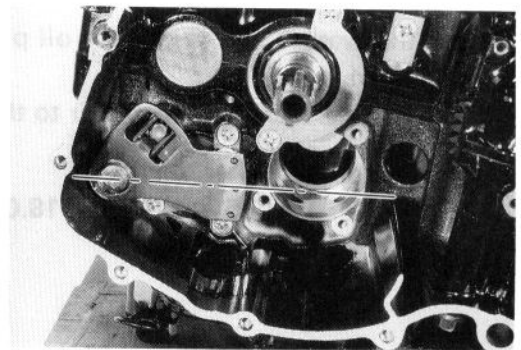
Tightening torque: 12 – 15 N·m

(1.2 – 1.5 kg·m, 8.5 – 11.0 lb-ft)

- Install the return spring ①, spacer ② and washer ③ onto the gearshift shaft.



- Install the gearshift shaft with the center of the gear on shaft aligned the center of gearshift cam driven gear.

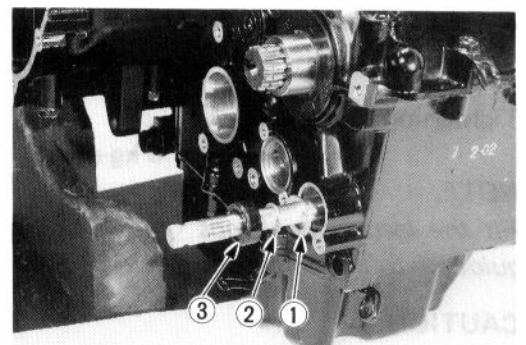


- Install the washer ① and fix the gearshift shaft with the circlip ②.
- Press-fit the oil seal ③ into the crankcase.

09900-06107: Snap ring pliers

CAUTION:

Replace the oil seal with a new one.

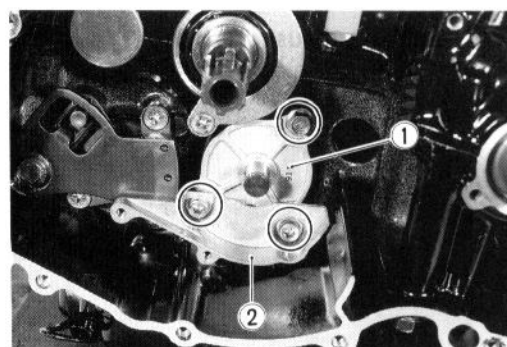


- Install the oil pump ① and oil separator inner case ② with the bolts.

Tightening torque: 8 – 12 N·m
(0.8 – 1.2 kg·m, 6.0 – 8.5 lb-ft)

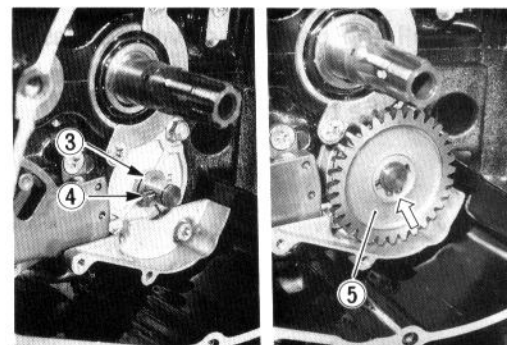
NOTE:

Before mounting the oil pump, apply engine oil to the sliding surfaces of the case, outer rotor, inner rotor and shaft.

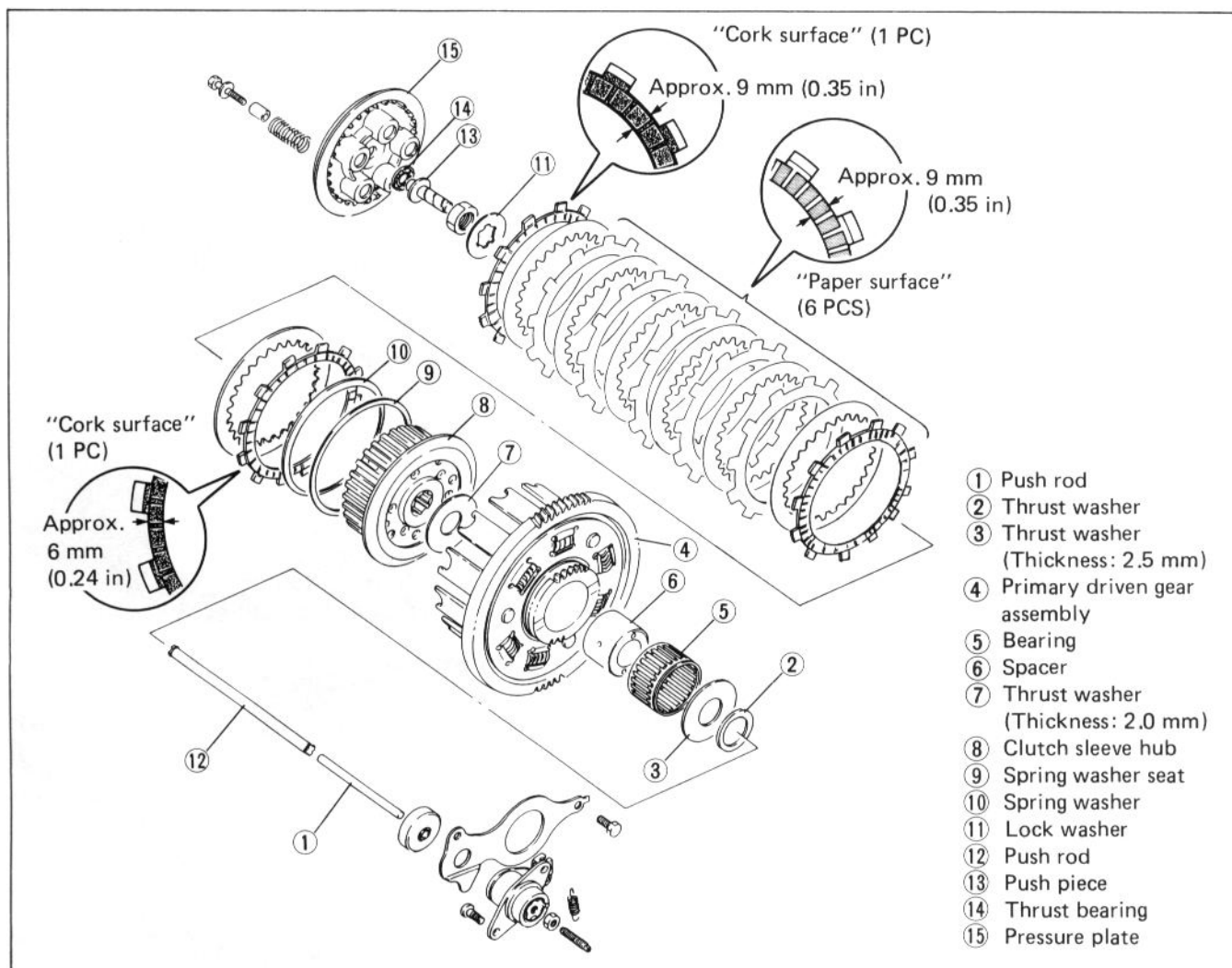


- Install the washer ③ and pin ④.
- Fix the oil pump driven gear ⑤ with the circlip.

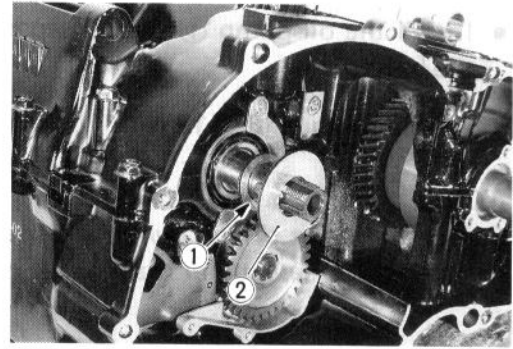
09900-06107: Snap ring pliers



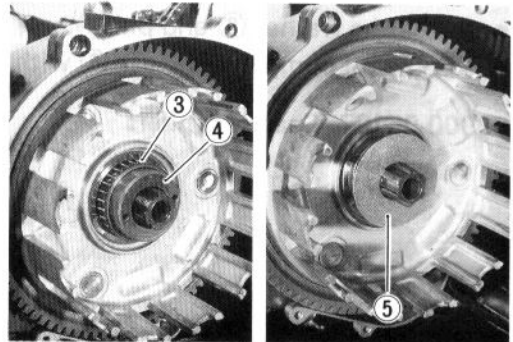
CLUTCH



- Install the thrust washers, ① and ②.



- Install the primary driven gear assembly onto the counter-shaft, then apply engine oil to the bearing ③ and spacer ④.
- Install the thrust washer ⑤.

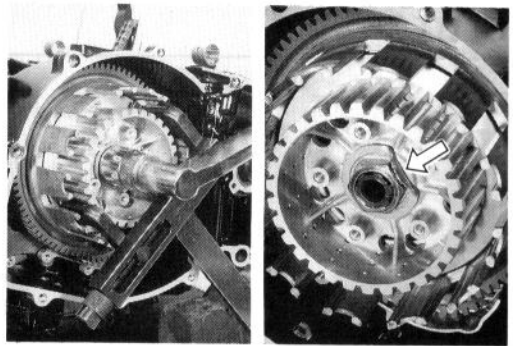


- Tighten the clutch sleeve hub nut to the specified torque.

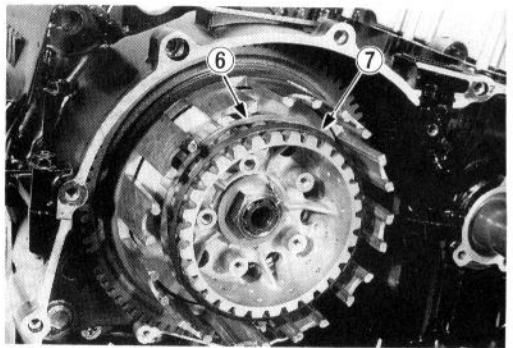
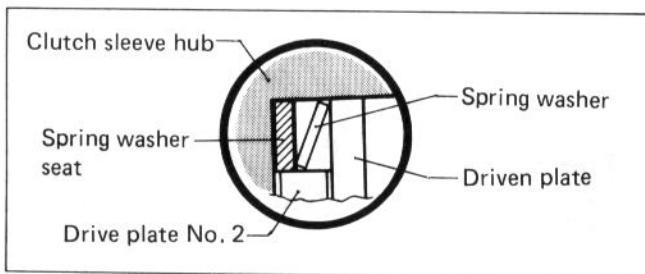
Clutch sleeve : 50 – 70 N·m
 hub nut (5.0 – 7.0 kg·m, 36.0 – 50.5 lb·ft)

09920-53710 : Clutch sleeve hub holder

- After tightening the clutch sleeve hub nut, be sure to lock the nut by firmly bending the tongue of the washer.



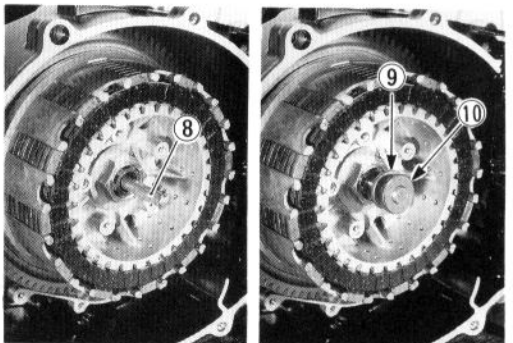
- Install the spring washer seat ⑥ and spring washer ⑦.



- Install the clutch drive and driven plates one by one into the clutch sleeve hub in the prescribed order. (Refer to page 3-50.)
- Install the push rod ⑧, push piece ⑨ and thrust bearing ⑩.

CAUTION:

The bearing face of the thrust bearing ⑩ faces push piece side.



- Tighten the clutch spring set bolts in the order.

NOTE:

Tighten the clutch spring set bolts in the manner indicated, tightening them by degrees until they attain a uniform tightness.

**Clutch spring set bolt: 7 – 11 N·m
(0.7 – 1.1 kg·m, 5.0 – 8.0 lb-ft)**

- Install the oil separator outer cover ①.
- Fit the generator stator spacer to the crankcase.

NOTE:

The chamfered face ① of the generator stator spacer faces outside.

- Apply a small quantity of THREAD LOCK SUPER "1322"/ "1333B" to the generator stator mounting screws and lead wire clamp screw.

(For U.S.A. model)

99000-32020: THREAD LOCK SUPER "1333B"

(For the other models)

99000-32110: THREAD LOCK SUPER "1322"

- Degrease the tapered portion of the generator rotor and also the crankshaft. Use nonflammable cleaning solvent to wipe off the oily or greasy matter to make these surfaces completely dry.

NOTE:

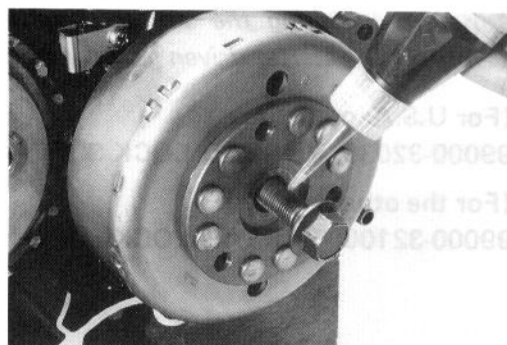
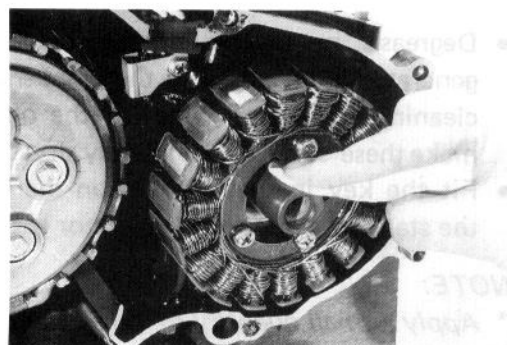
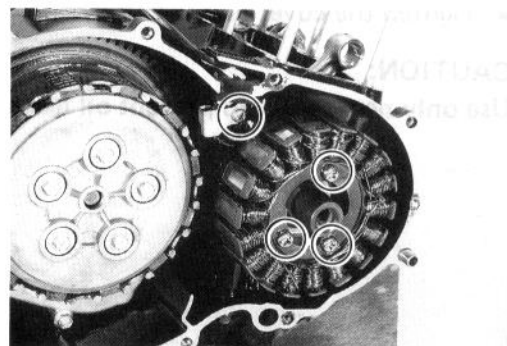
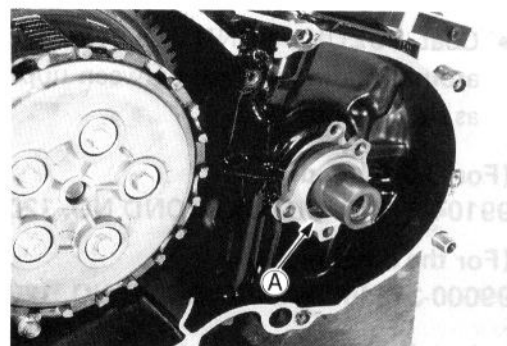
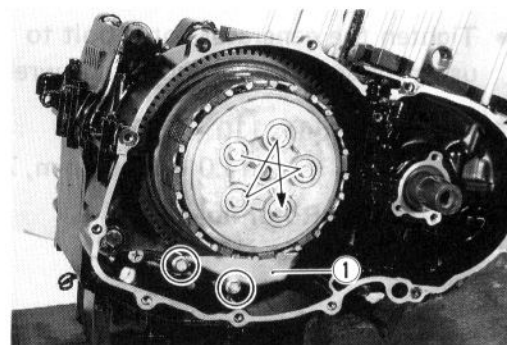
Apply a small quantity of THREAD LOCK SUPER "1303"/ "1305" to the generator rotor bolt.

(For U.S.A. model)

99000-32030: THREAD LOCK SUPER "1303"

(For the other models)

99000-32100: THREAD LOCK SUPER "1305"



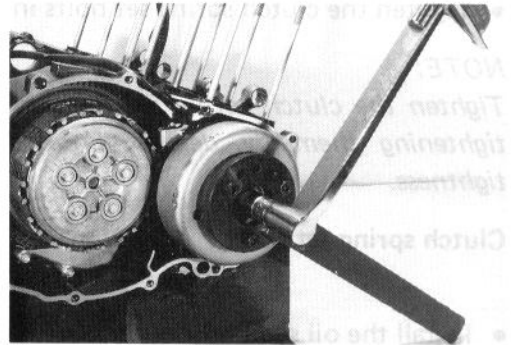
3-53 ENGINE

- Tighten the generator rotor bolt to the specified torque by using the special tool and torque wrench.

Tightening torque: 110 – 130 N·m

(11.0 – 13.0 kg·m, 79.5 – 94.0 lb·ft)

09930-32420: Rotor holder



- Coat SUZUKI BOND NO. 1207B lightly to the portion around mating surface between upper and lower crankcases as shown in the Fig.

(For U.S.A. model)

99104-31140: SUZUKI BOND NO. 1207B

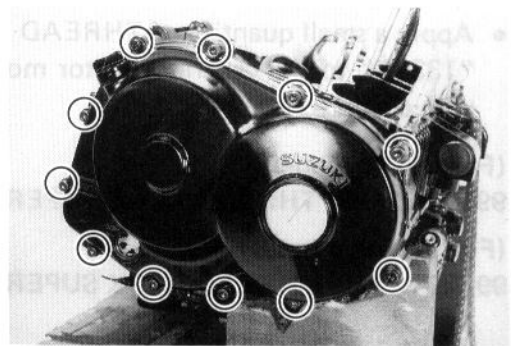
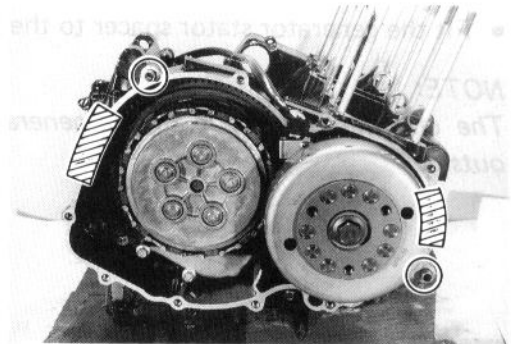
(For the other models)

99000-31140: SUZUKI BOND NO. 1207B

- Install the dowel pins, a new gasket and clutch cover.
- Tighten the cover bolts securely.

CAUTION:

Use only new gasket to prevent oil leakage.



- Degrease the tapered portion of the starter clutch/signal generator rotor and also the crankshaft. Use nonflammable cleaning solvent to wipe off the oily or greasy matter to make these surfaces completely dry.
- Fit the key in the key slot on the crankshaft, then install the starter clutch/signal generator rotor.

NOTE:

* Apply a small quantity of **THREAD LOCK SUPER "1303"/"1305"** to the starter clutch bolt.

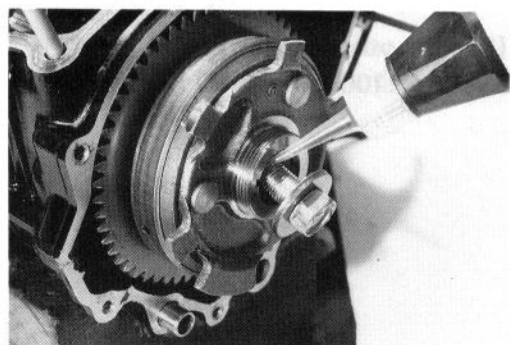
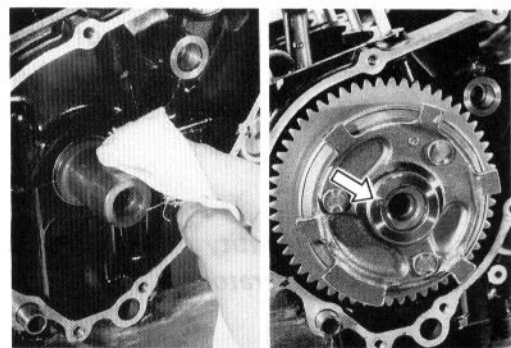
* Before installing the starter clutch/signal generator rotor, inspect the starter driven gear for smooth movement.

(For U.S.A. model)

99000-32030: THREAD LOCK SUPER "1303"

(For the other models)

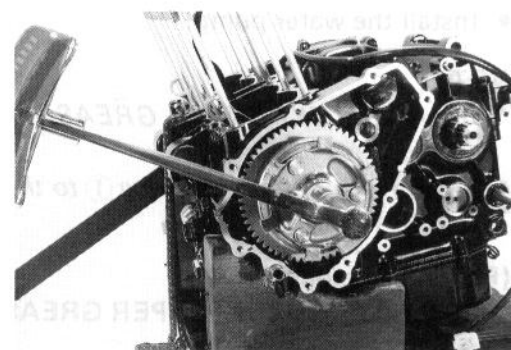
99000-32100: THREAD LOCK SUPER "1305"



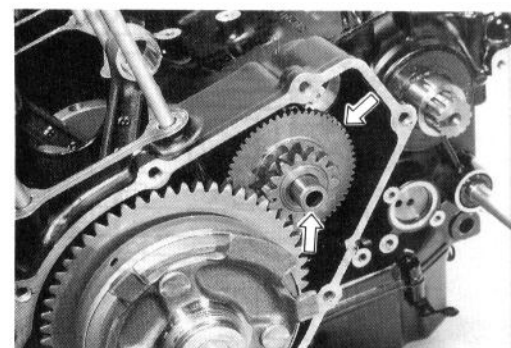
- Hold the generator rotor bolt with a box wrench and tighten the starter clutch bolt to the specified torque.

Tightening torque: 85 – 95 N·m

(8.5 – 9.5 kg-m, 61.5 – 68.5 lb-ft)



- Install the starter idle gear and its shaft.



- Install the starter motor.

NOTE:

* Apply *SUZUKI SUPER GREASE "A"* to the starter motor O-ring.

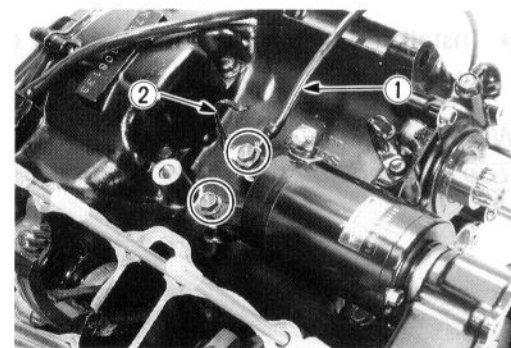
* Fit the engine ground wire ① and lead wire clamp ② to the starter motor mounting bolt.

(For U.S.A. model)

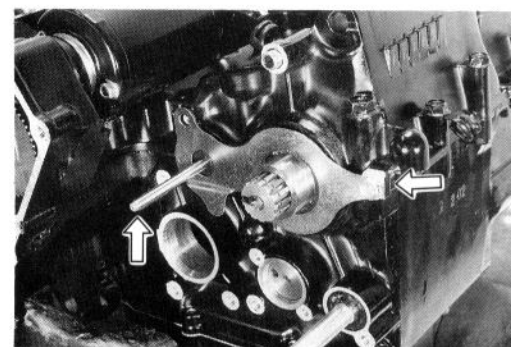
99000-25030: *SUZUKI SUPER GREASE "A"*

(For the other models)

99000-25010: *SUZUKI SUPER GREASE "A"*



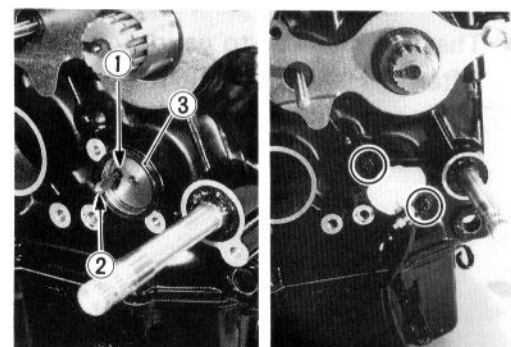
- Install the oil seal retainer and positively bend the lock portion of the retainer.
- Insert the clutch push rod into the countershaft.



- Install the neutral position indicator switch.

NOTE:

When installing the neutral position indicator switch, be sure to locate the spring, ① switch contact ② and O-ring ③.



3-55 ENGINE

- Install the water pump.

NOTE:

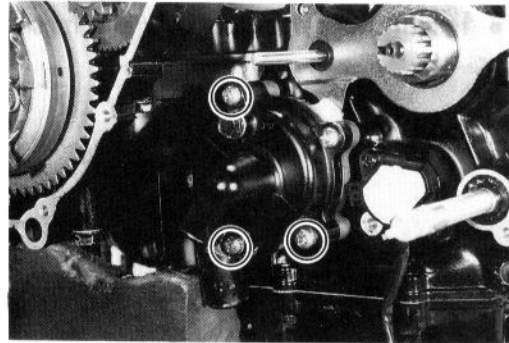
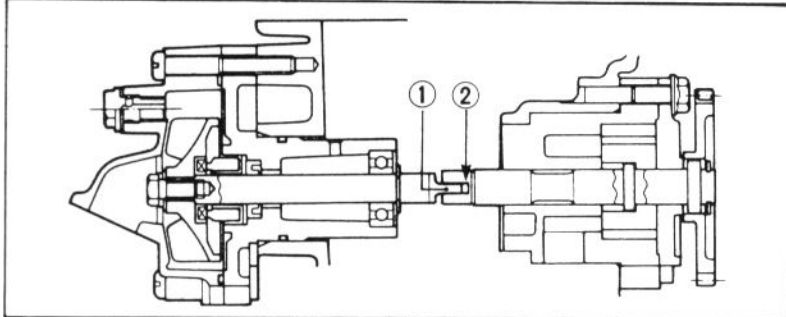
- * Apply **SUZUKI SUPER GREASE "A"** to the water pump O-ring.
- * Set the water pump shaft lug ① to the oil pump shaft slit ②.

(For U.S.A. model)

99000-25030: SUZUKI SUPER GREASE "A"

(For the other models)

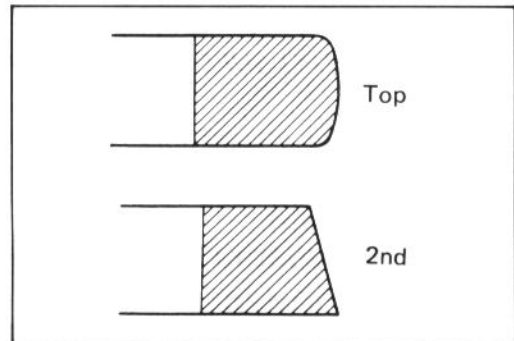
99000-25010: SUZUKI SUPER GREASE "A"



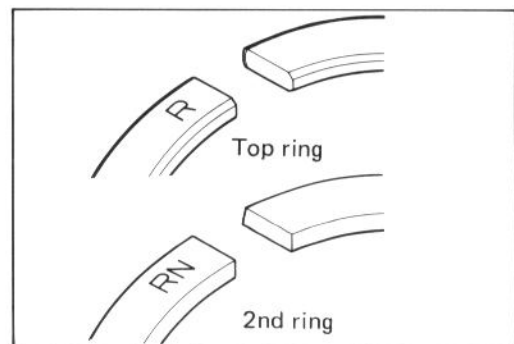
- Install the piston rings in the order of oil ring, 2nd ring and top ring.

NOTE:

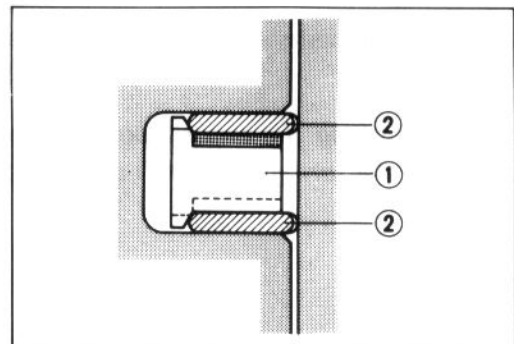
Top ring and 2nd ring differ in the shape of ring face.



- Top and 2nd rings have letter "R" and "RN" marked on the side. Be sure to bring the marked side to top when fitting them to the piston.

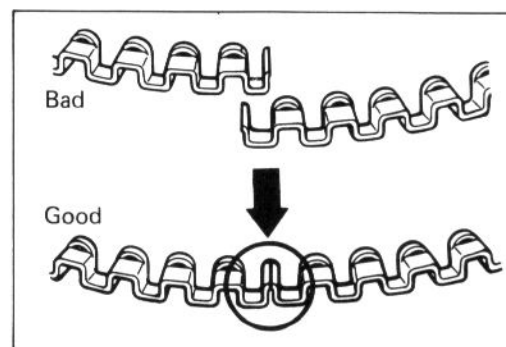


- The first member to go into the oil ring groove is spacer ①. After placing spacer, fit the two side rails ②. Side designations, top and bottom, are not applied to the spacer and side rails: you can position each either way.

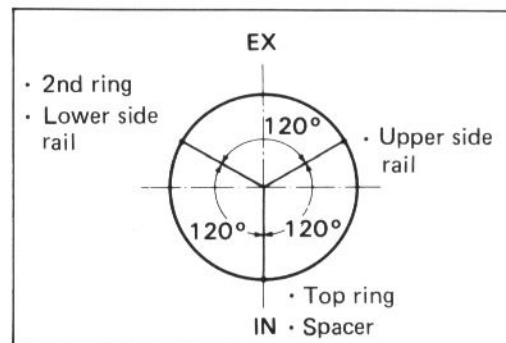


CAUTION:

When installing the spacer, be careful not to allow its two ends to overlap in the groove.



- Position the gaps of the three rings as shown. Before inserting each piston into the cylinder, check that the gaps are so located.

**NOTE:**

When replacing the cylinder stud bolts, tighten them to the specified torque.

Tightening torque: 13 – 16 N·m
(1.3 – 1.6 kg·m, 9.5 – 11.5 lb-ft)

- The triangle mark on the piston head faces exhaust port side.
- Be sure to install the pistons in the cylinder from which they were taken out in disassembly, refer to the letter mark, "1" through "4", scribed on the piston.
- Have each piston pin moly paste oiled lightly before installing it.
- Place a cloth beneath the piston, and install the circlips.

CAUTION:

Be sure to use new circlips.

- Place the dowel pins and new cylinder gasket on the crankcase.

NOTE:

Be sure to identify the top surface by "UP" mark ① on the cylinder gasket as shown in the Fig.

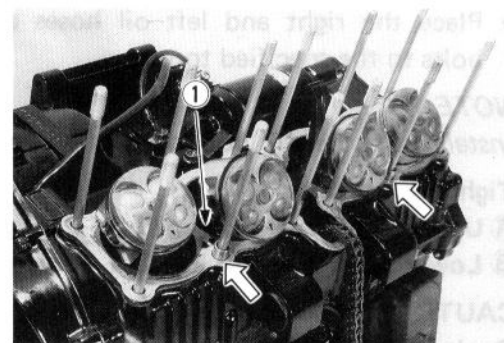
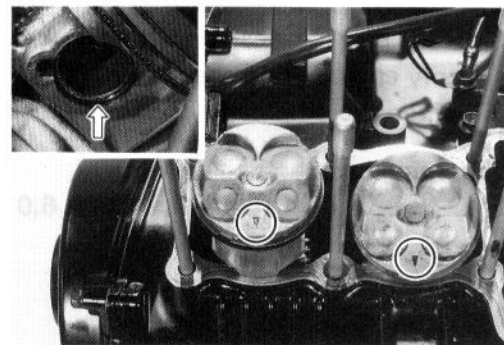
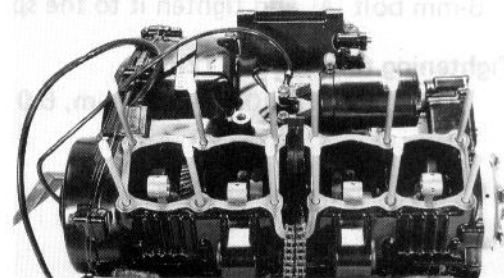
CAUTION:

Use a new gasket to prevent oil leakage.

- Install the piston ring holders to each piston.

09916-74521: Holder body

09916-74530: Band



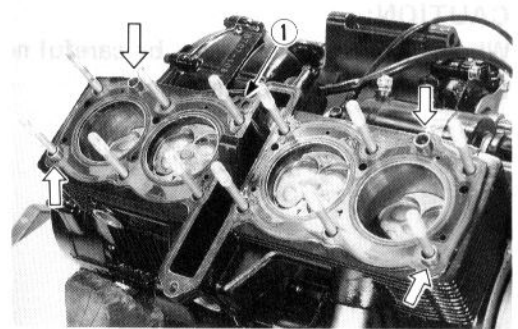
- Place the dowel pins and new cylinder head gasket on the cylinder.

NOTE:

Be sure to identify the top surface by "UP" mark ① on the cylinder head gasket as shown in the Fig.

CAUTION:

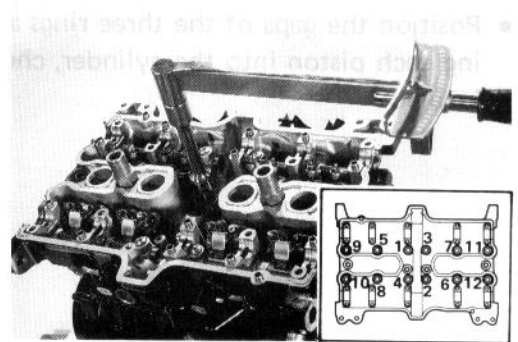
Use a new gasket to prevent gas leakage.



- Tighten the cylinder head nuts to the specified torque with a torque wrench sequentially in the ascending order of numbers.

Tightening torque: 25 – 29 N·m

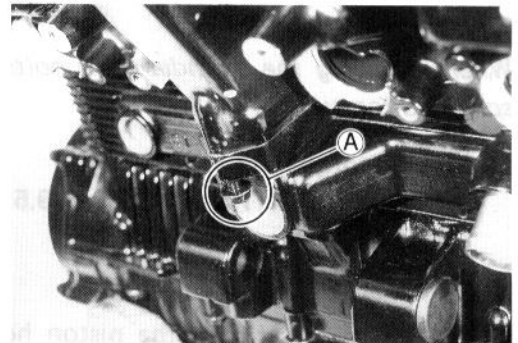
(2.5 – 2.9 kg·m, 18.0 – 21.0 lb-ft)



- After firmly tightening the twelve 8-mm nuts, install one 6-mm bolt (A) and tighten it to the specified torque.

Tightening torque: 8 – 12 N·m

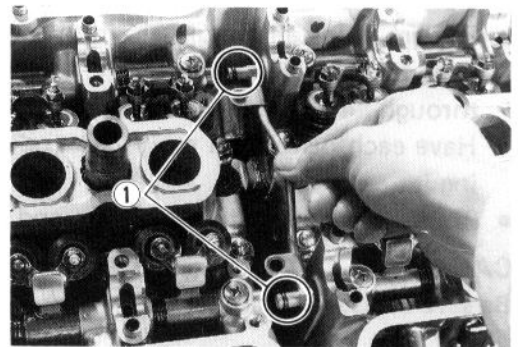
(0.8 – 1.2 kg·m, 6.0 – 8.5 lb-ft)



- Fit the new O-rings ① to the oil pipe.
- Apply engine oil to the O-rings ①.
- Tighten the oil pipe bolts to the specified torque.

Tightening torque: 8 – 12 N·m

(0.8 – 1.2 kg·m, 6.0 – 8.5 lb-ft)



- Place the right and left oil hoses and tighten the union bolts to the specified torque.

NOTE:

Install the gaskets to both sides of union.

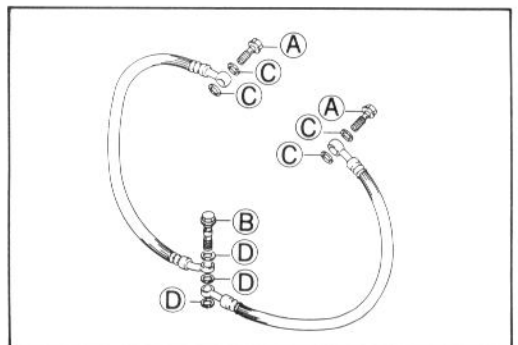
Tightening torque:

(A) Upper side : 18 – 22 N·m (1.8 – 2.2 kg·m, 13.0 – 16.0 lb-ft)

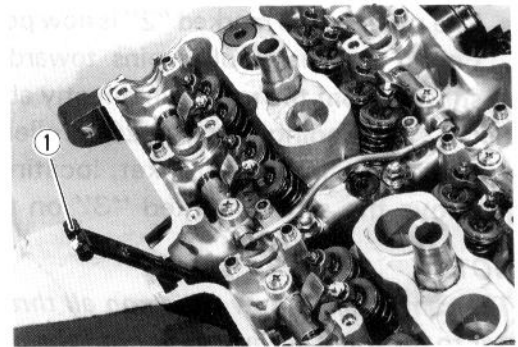
(B) Lower side : 20 – 24 N·m (2.0 – 2.4 kg·m, 14.5 – 17.5 lb-ft)

CAUTION:

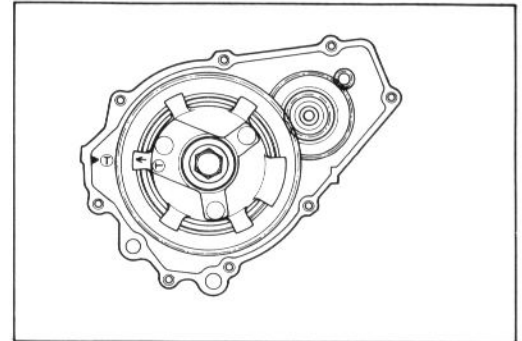
Replace the gaskets (C) and (D) with new ones to prevent oil leakage.



- Place the cam chain guide ① properly.



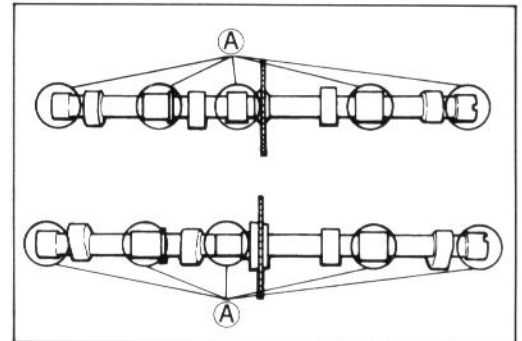
- While holding down the cam chain, rotate the crankshaft in normal direction to bring the arrow "T" mark on the signal generator rotor to the arrow "T" mark on the crankcase.



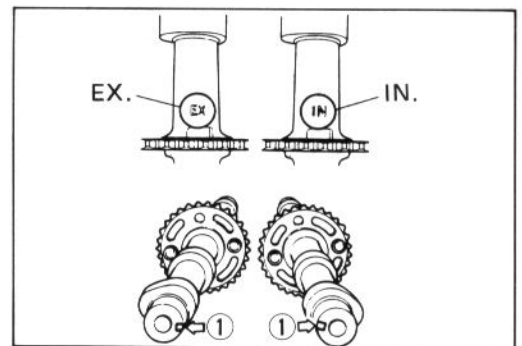
NOTE:

Just before placing the camshaft on the cylinder head, apply **SUZUKI MOLY PASTE** to its journals, fully coating each journal (A) with the paste taking care not to leave any dry spot. Apply engine oil to the camshaft journal holders.

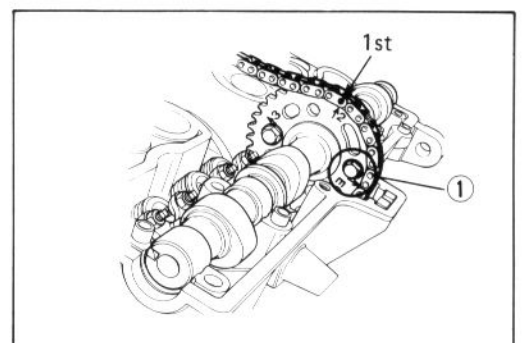
99000-25140: SUZUMI MOLY PASTE



- The exhaust camshaft can be distinguished from that of the intake by the embossed letters "EX" (for exhaust) as against letters "IN" (for intake). Similarly, the right end can be distinguished by the notch (1) at the right end.



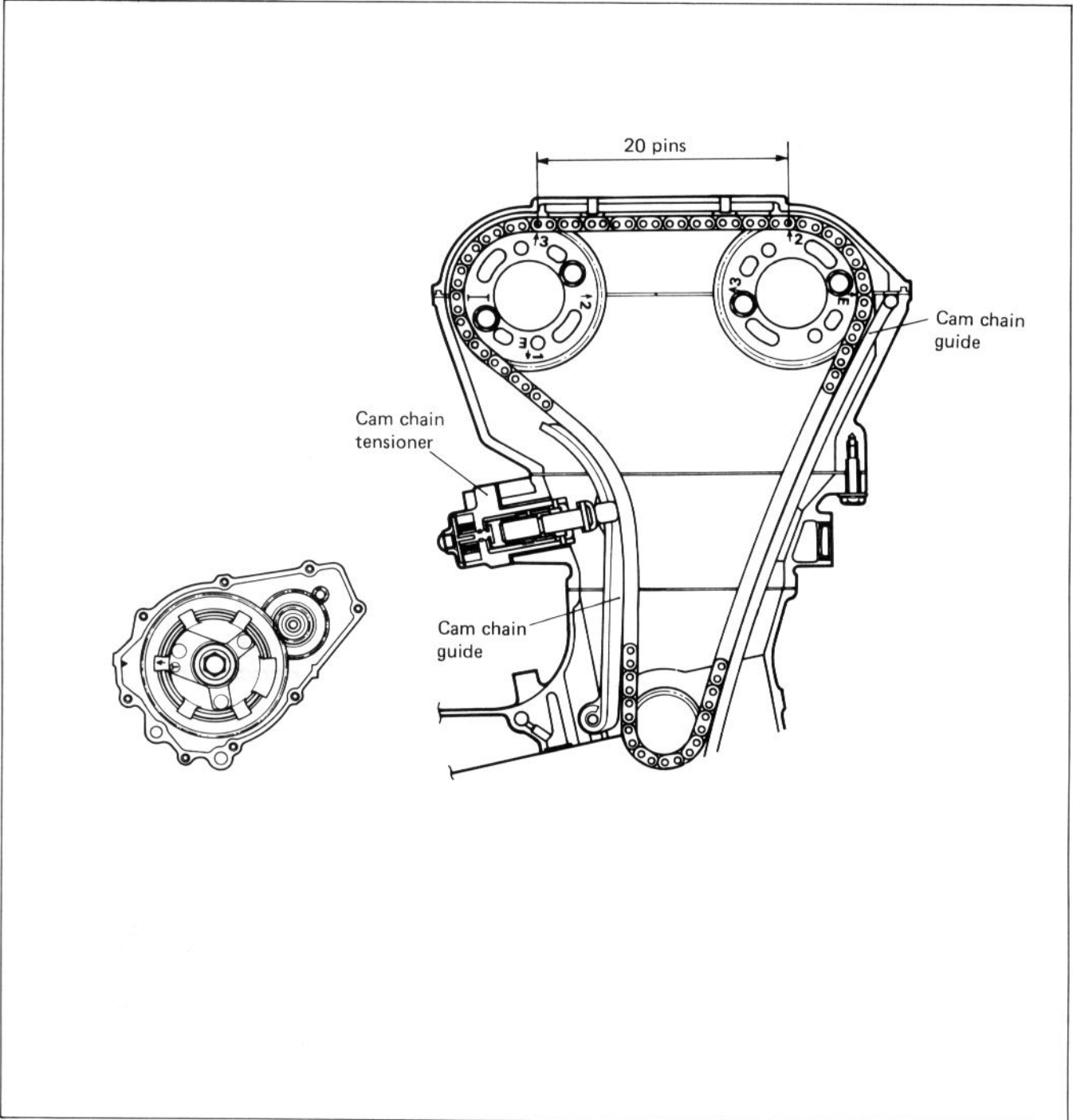
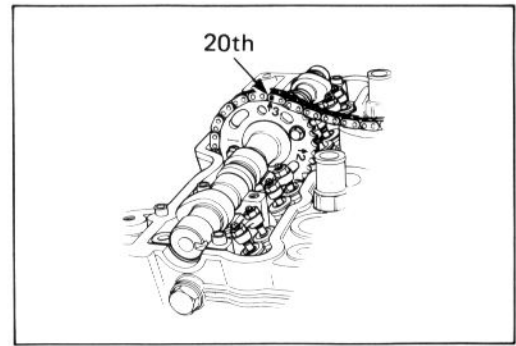
- With "T" mark accurately lined up with the timing mark, hold the camshaft steady and lightly pull up the chain to remove the slack between the crank sprocket and exhaust sprocket.
- Exhaust sprocket bears an arrow marked "1" indicated as (1). Turn over the exhaust camshaft so that the arrow points flush with the gasketed surface of the cylinder head. Engage the cam chain with this sprocket.



- The other arrow marked "2" is now pointing straight upward. Count the chain roller pins toward the intake camshaft, starting from the roller pin directly above this arrow marked "2" and ending with the 20th roller pin. Engage the cam chain with intake sprocket, locating the 20th pin at the above the arrow marked "3" on the intake sprocket.

NOTE:

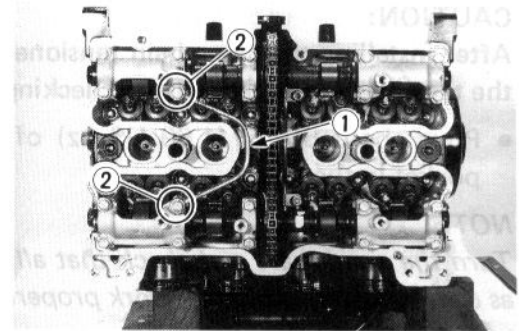
The cam chain is now riding on all three sprockets. Be careful not to disturb the crankshaft until the camshaft journal holders and cam chain tensioner are secured.



- Each camshaft journal holder is identified with a cast-on letter. Install the dowel pins to each camshaft journal holder.
- Place the cylinder head oil pipe ① to the camshaft journal holders.

NOTE:

Fit the washer to each oil pipe union bolt ②.



- Secure the camshaft journal holders evenly by tightening the camshaft journal holder bolts sequentially. Try to equalize the pressure by moving the wrench diagonally from one bolt to another and from one camshaft journal holder to another, to push shafts down evenly.

NOTE:

Damage to head or camshaft journal holder thrust surfaces may result if the camshaft journal holders are not drawn down evenly.

- Tighten the camshaft journal holder bolts to the specified torque.

Tightening torque: 8 – 12 N·m

(0.8 – 1.2 kg·m, 6.0 – 8.5 lb-ft)

CAUTION:

The camshaft journal holder bolts are made of special material and much superior in strength compared with other type of high strength bolts.

Take special care not to use other types of bolts instead of these special bolts. To identify these bolts, each of them has a figure "9" on its head.

- Turn the slotted end of the cam chain tensioner to lock it with a screwdriver in the clockwise direction.
- Install the cam chain tensioner on the cylinder.

Tightening torque: 6 – 8 N·m

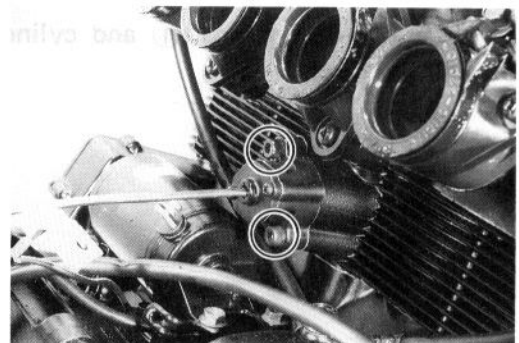
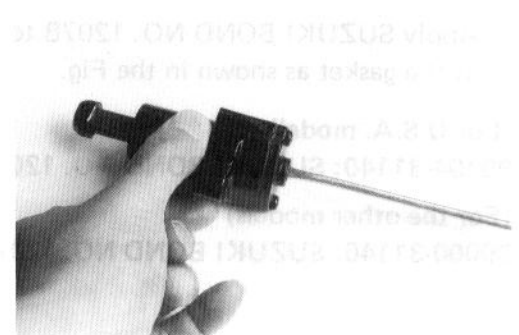
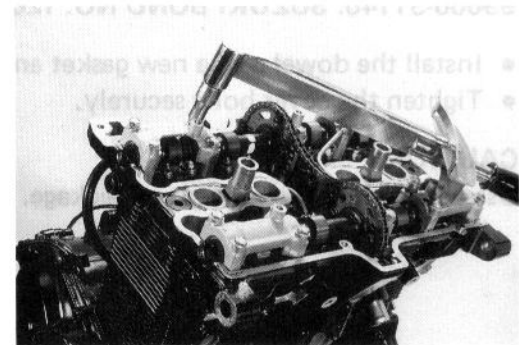
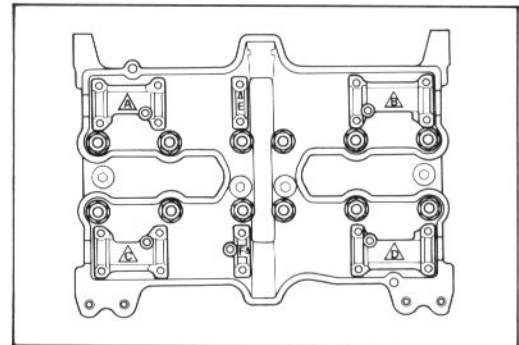
(0.6 – 0.8 kg·m, 4.5 – 6.0 lb-ft)

09911-73730: "T" type hexagon wrench (5 mm)

- Turn back and pull out the screwdriver from the cam chain tensioner. As the cylinder turns, the tensioner rod is advanced under spring force and pushes the tensioner against the cam chain.

NOTE:

The cam chain tensioner is maintained at the proper tension by an automatically adjusted tensioner. Before installing the cam chain tensioner, inspect the smooth movement.



CAUTION:

After installing the cam chain tensioner, check to be sure that the tensioner work properly by checking the slack of cam chain.

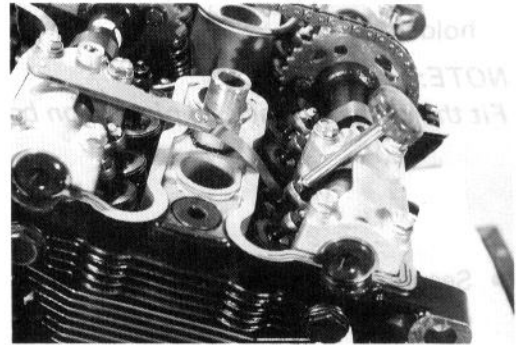
- Pour about 50 ml (1.69 US oz) of engine oil in each oil pocket in the head.

NOTE:

Turn the crankshaft and check that all the moving parts such as cam follower, camshaft, work properly.

CAUTION:

Be sure to check and adjust the valve clearance. (Refer to page 2-5.)



- Coat SUZUKI BOND NO. 1207B lightly to the portion around mating surface between upper and lower crankcases as shown in the Fig.

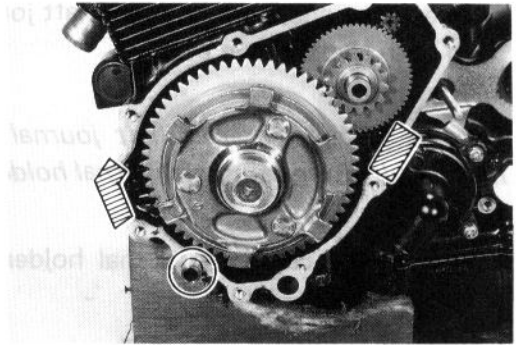
(For U.S.A. model)

99104-31140: SUZUKI BOND NO. 1207B

(For the other models)

99000-31140: SUZUKI BOND NO. 1207B

- Install the dowel pin, a new gasket and starter clutch cover.
- Tighten the cover bolts securely.



CAUTION:

Use a new gasket to prevent oil leakage.

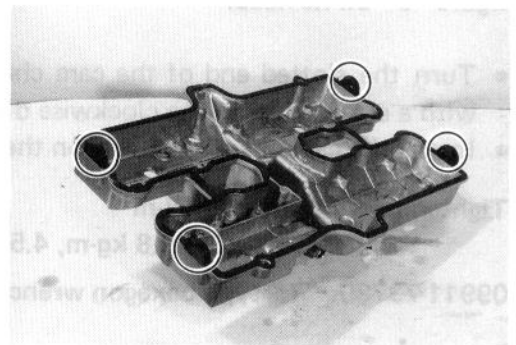
- Apply SUZUKI BOND NO. 1207B to the four cam end caps of the gasket as shown in the Fig.

(For U.S.A. model)

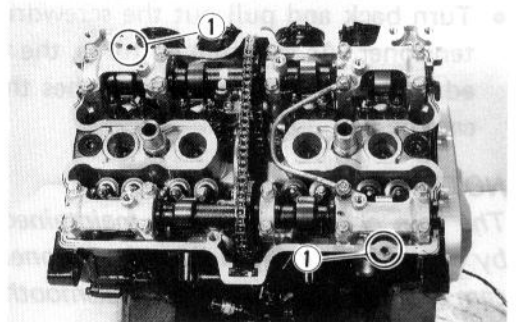
99104-31140: SUZUKI BOND NO. 1207B

(For the other models)

99000-31140: SUZUKI BOND NO. 1207B



- Place the dowel pins ① and cylinder head cover on the cylinder head.



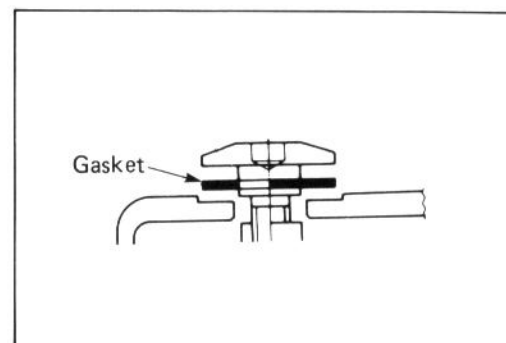
- Seat the six gaskets to each exact position.

CAUTION:

Replace the gaskets with new ones to prevent oil leakage.

NOTE:

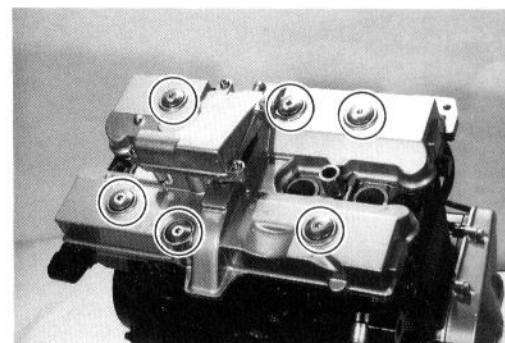
Apply engine oil to the gasket surfaces.



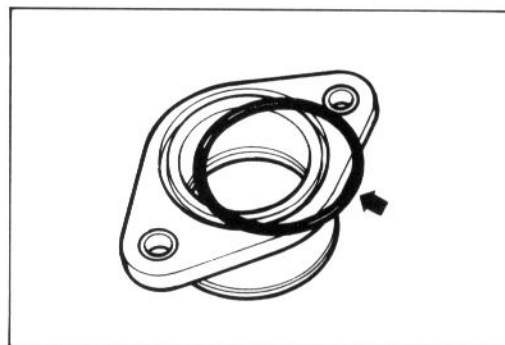
- Tighten the cylinder head cover bolts to the specified torque.

Tightening torque: 8 – 12 N·m

(0.8 – 1.2 kg·m, 6.0 – 8.5 lb-ft)

**CAUTION:**

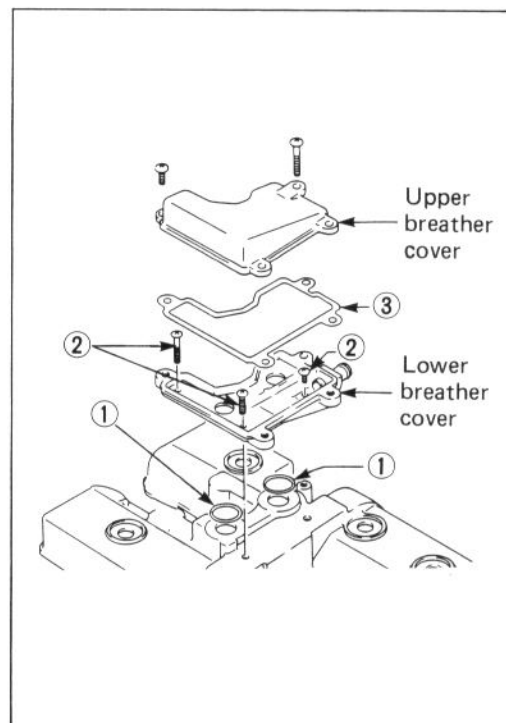
When replacing the intake pipe, use a new O-ring to prevent sucking air from the joint.

**BREATHER COVER SERVICING**

- Apply engine oil to the O-rings ①.
- Apply SUZUKI BOND NO. 1207B to the mating surfaces of the cylinder head cover and lower breather cover.
- Apply SUZUKI THREAD LOCK SUPER "1303" to the screws ②.

CAUTION:

Replace the O-rings ① and gasket ③ with new ones.



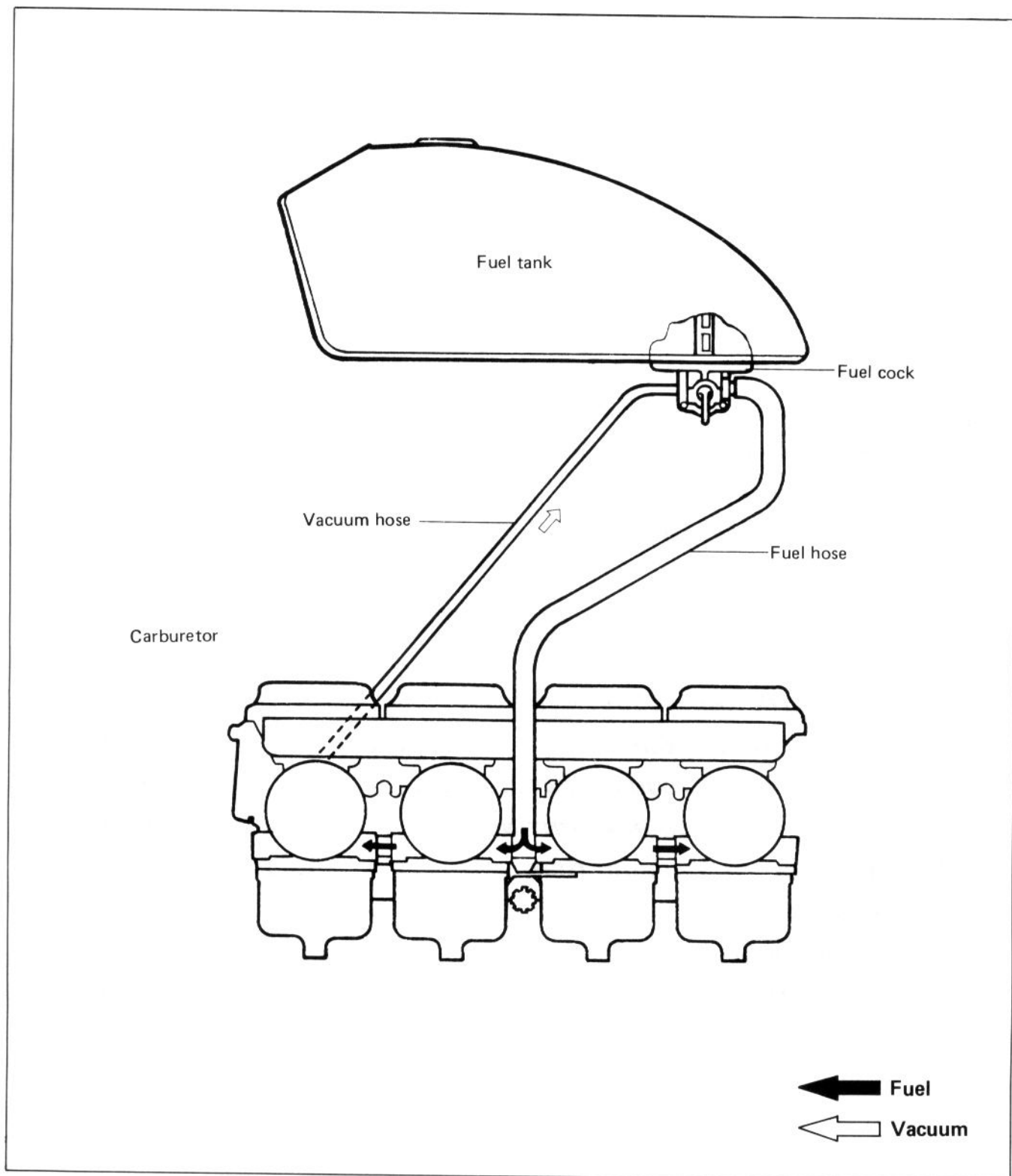
FUEL AND LUBRICATION SYSTEM

CONTENTS

FUEL SYSTEM	4- 1
FUEL TANK AND FUEL COCK	4- 2
FUEL TANK REMOVAL	4- 2
FUEL COCK REMOVAL	4- 2
INSPECTION AND CLEANING	4- 2
CARBURETOR	4- 3
CONSTRUCTION	4- 3
SPECIFICATIONS	4- 4
I.D.NO. LOCATION	4- 5
DIAPHRAGM AND PISTON OPERATION	4- 6
SLOW SYSTEM	4- 7
MAIN SYSTEM	4- 8
STARTER SYSTEM	4- 9
FLOAT SYSTEM	4- 9
REMOVAL	4-10
DISASSEMBLY	4-10
INSPECTIN AND ADJUSTMENT	4-10
NEEDLE VALVE INSPECTION	4-10
FLOAT HEIGHT ADJUSTMENT	4-10
REASSEMBLY AND REMOUNTING	4-10
BALANCE OF CARBURETORS	4-11
LUBRICATION SYSTEM	4-13
OIL PRESSURE	4-13
OIL FILTER	4-13
OIL SUMP FILTER	4-13
ENGINE LUBRICATION SYSTEM CHART	4-14

FUEL SYSTEM

When turning the starter motor, negative pressure is generated in the combustion chamber. This negative pressure works on the diaphragm of fuel cock through passage way provided in the carburetor main bore and vacuum hose, and diaphragm builds up a negative pressure which is higher than the spring pressure. Fuel valve in the fuel cock is forced to open due to diaphragm operation, and thus allows fuel to flow into the carburetor float chamber.



FUEL TANK AND FUEL COCK

FUEL TANK REMOVAL

- Remove the seat and air cleaner side cover. (See page 1-12.)
- Remove the fuel tank mounting bolts.
- Disconnect the fuel hose and vacuum hose from the fuel cock.
- Disconnect the fuel tank water drain hose.
- Remove the fuel tank.

WARNING:

Gasoline is very explosive. Extreme care must be taken.

FUEL COCK REMOVAL

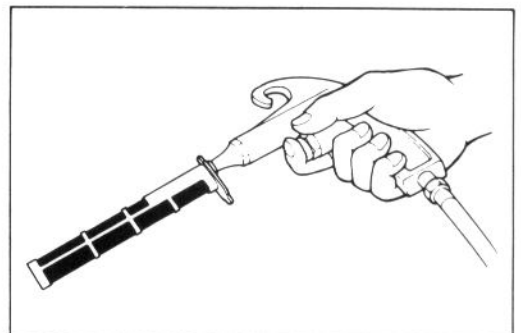
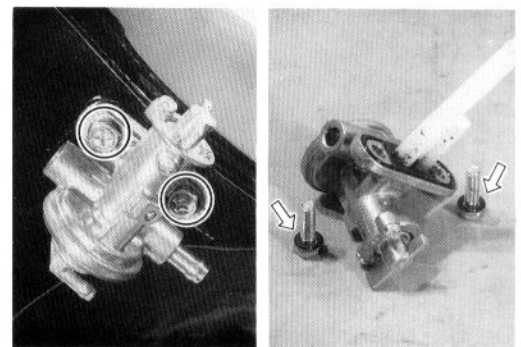
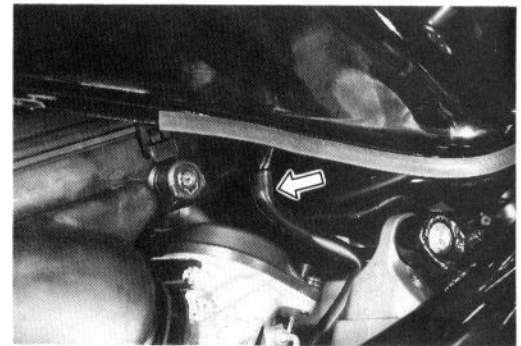
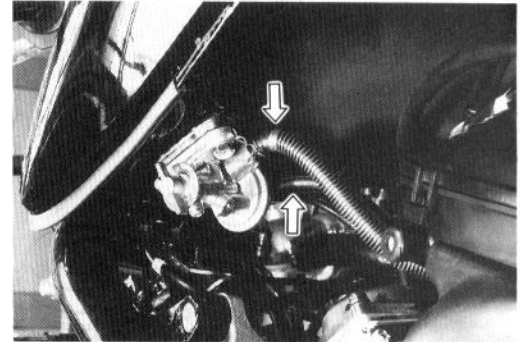
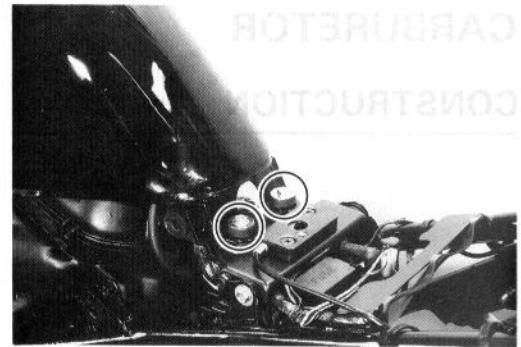
- Remove the fuel cock by removing the bolts.

WARNING:

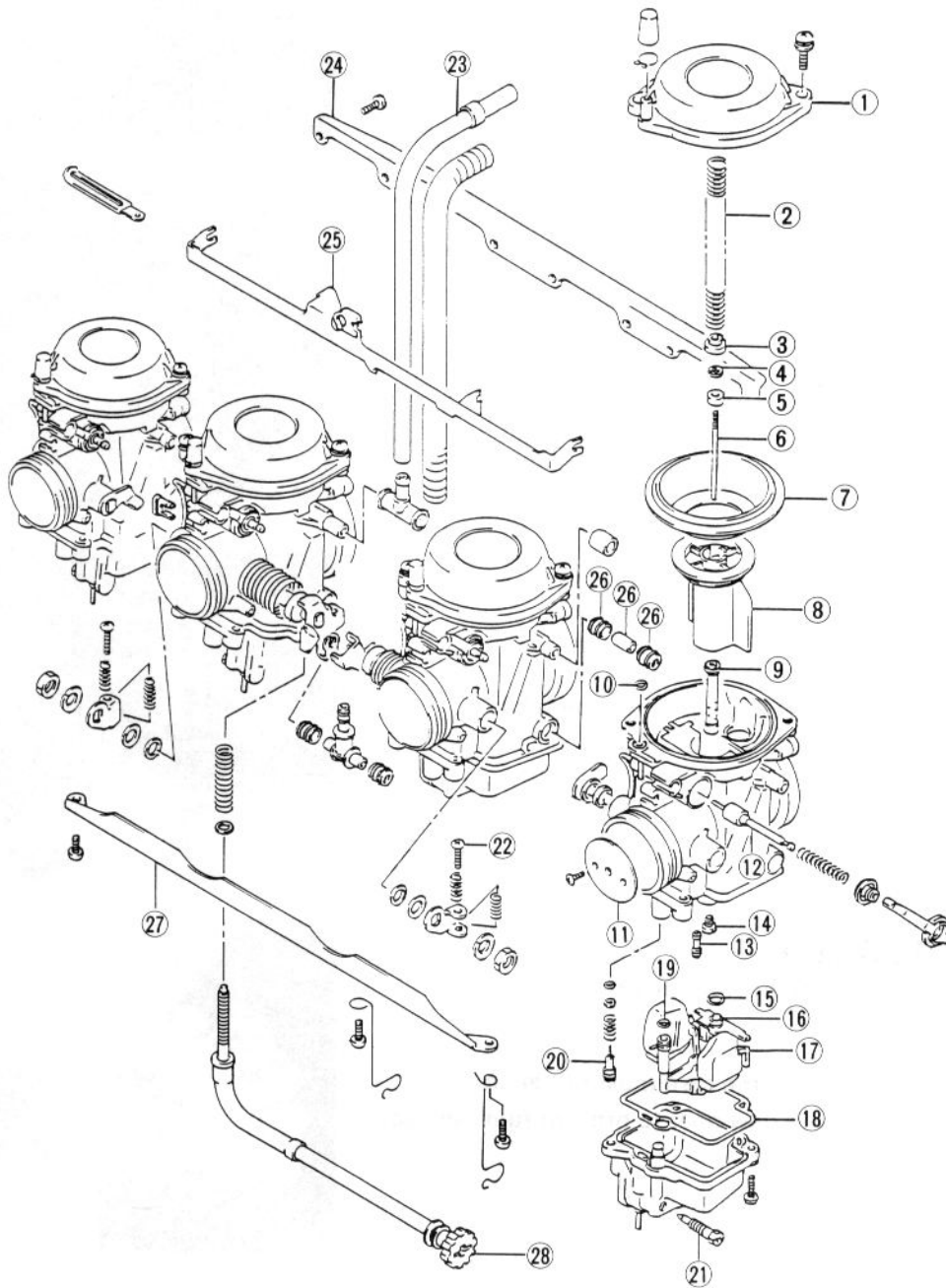
Gasoline is very explosive. Extreme care must be taken.
Gaskets must be replaced with new ones to prevent fuel leakage.

INSPECTION AND CLEANING

If the fuel strainer is dirty with sediment or rust, fuel will not flow smoothly and loss in engine power may result. Clean the fuel strainer with compressed air.



CARBURETOR CONSTRUCTION



- | | | | |
|---------------|-------------------|----------------|--------------------------------|
| ① Top cap | ⑧ Piston valve | ⑮ O-ring | ⑳ Throttle valve balance screw |
| ② Spring | ⑨ Needle jet | ⑯ Needle valve | ㉑ Air vent hose |
| ③ Spring seat | ⑩ O-ring | ⑰ Float ass'y | ㉒ Carburetor set upper plate |
| ④ E-ring | ⑪ Throttle valve | ⑱ Gasket | ㉓ Starter shaft lever |
| ⑤ Washer | ⑫ Starter plunger | ⑲ O-ring | ㉔ Fuel hose connector set |
| ⑥ Jet needle | ⑬ Pilot jet | ㉑ Pilot screw | ㉕ Carburetor set lower plate |
| ⑦ Diaphragm | ⑭ Main jet | ㉒ Drain screw | ㉖ Throttle stop screw |

SPECIFICATIONS

ITEM	SPECIFICATION	
	E-03	E-33
Carburetor type	MIKUNI BST32SS	←
Bore size	32 mm	←
I.D. No	10D2	10D4
Idle r/min.	1 400 ± 50 r/min.	←
Float height	14.6 ± 1.0 mm	←
Main jet (M.J.)	# 102.5	←
Main air jet (M.A.J.)	0.6 mm	←
Jet needle (J.N.)	5EZ74	←
Needle jet (N.J.)	0-9	←
Throttle valve (Th.V.)	# 130	←
Pilot jet (P.J.)	# 32.5	←
By-pass (B.P.)	# ¹ 0.8, # ² 0.8, # ³ 0.8 mm	←
Pilot outlet (P.O.)	0.8 mm	0.9 mm
Valve seat (V.S.)	2.0 mm	←
Starter jet (G.S.)	# 32.5	←
Pilot screw (P.S.)	PRE-SET	←
Throttle cable play	0.5—1.0 mm (0.02—0.04 in)	←

ITEM	SPECIFICATION		
	E-02,04,21,25,28,34	E-24	E-22
Carburetor type	BST33SS	←	←
Bore size	33 mm	←	←
I.D. No.	10D1	10D3	10D5
Idle r/min.	1 300 ± 100 r/min	←	1 400 ± 50 r/min
Float height	14.6 ± 1.0 mm	←	←
Main jet (M.J.)	# 100	←	←
Main air jet (M.A.J.)	0.6 mm	←	←
Jet needle (J.N.)	5EZ67-3rd	←	←
Needle jet (N.J.)	P-0	←	←
Throttle valve (Th.V.)	# 130	←	←
Pilot jet (P.J.)	# 32.5	←	←
By-pass (B.P.)	# ¹ 0.8, # ² 0.8, # ³ 0.8 mm	←	←

4-5 FUEL AND LUBRICATION SYSTEM

ITEM	SPECIFICATION		
	E-02,04,21,25,28,34	E-24	E-22
Pilot outlet (P.O.)	0.7 mm	←	←
Valve seat (V.S.)	2.0 mm	←	←
Starter jet (G.S.)	# 32.5	←	←
Pilot screw (P.S.)	PRE-SET (1½ turns back)	←	PRE-SET (1¼ turns back)
Throttle cable play	0.5–1.0 mm (0.02–0.04 in)	←	←

E-02 : England

E-03 : U.S.A.

E-04 : France

E-21 : Belgium

E-22 : W. Germany

E-24 : Australia

E-25 : Netherland

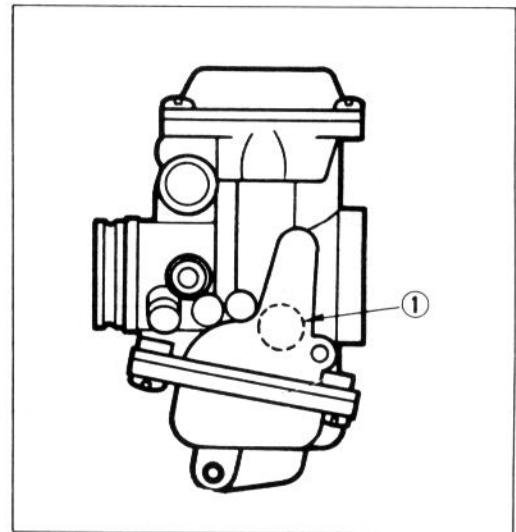
E-28 : Canada

E-33 : California (U.S.A.)

E-34 : Italy

I.D.NO. LOCATION

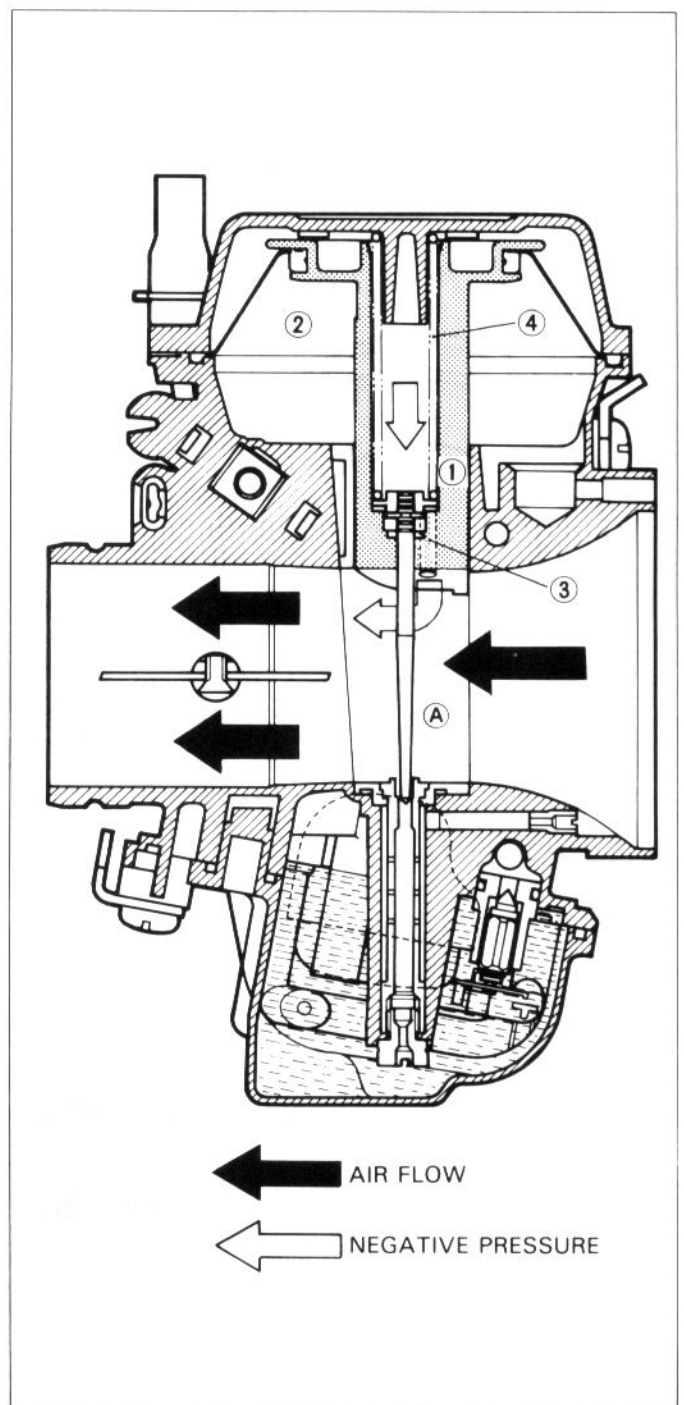
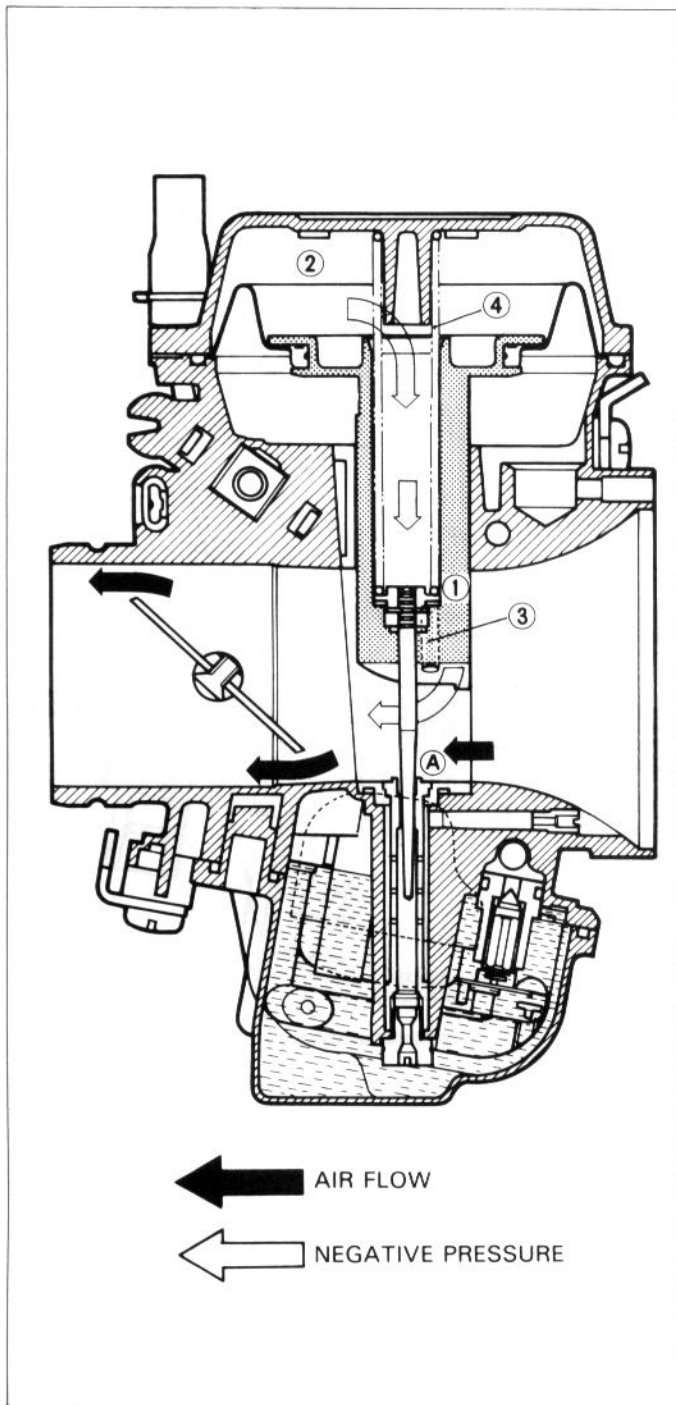
Each carburetor has I.D. Number ① printed on the carburetor body according to its specification.



DIAPHRAGM AND PISTON OPERATION

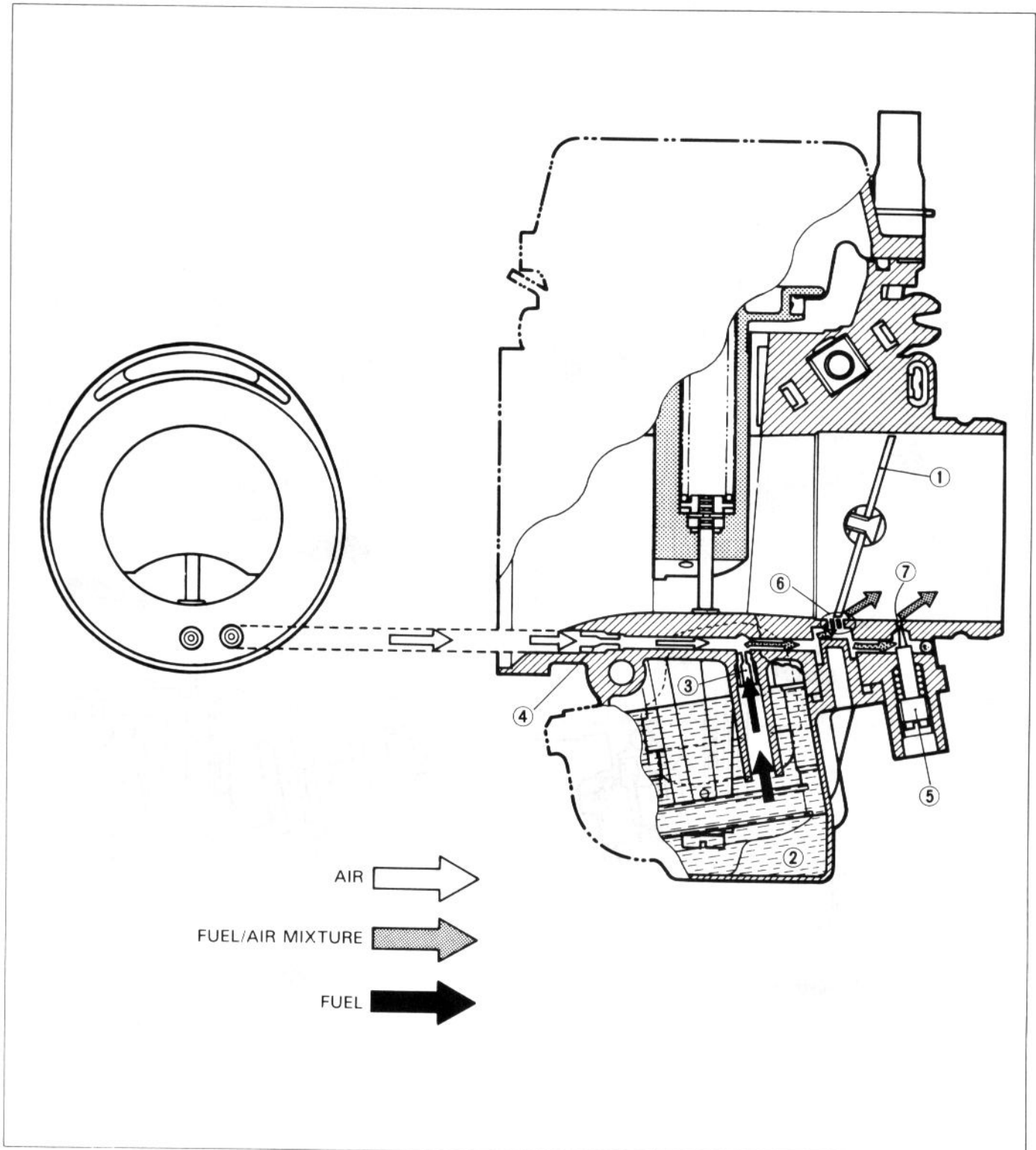
The carburetor is a variable-venturi type, whose venturi cross section area is increased or decreased automatically by the piston valve ① which moves according to the negative pressure present on the downstream side of the venturi (A). Negative pressure is admitted into the diaphragm chamber ② through two orifices ③ provided in the piston valve ①.

Rising negative pressure overcomes the spring ④ force, causing the piston valve ① to rise to increase the said area and thus prevent the air velocity from increasing. Thus, air velocity in the venturi passage is kept relatively constant for improved fuel atomization and for securing optimum ratio of fuel/air mixture.



SLOW SYSTEM

This system supplies fuel during engine operation with throttle valve ① closed or slight opened. The fuel from float chamber ② is metered by pilot jet ③ where it mixes with air coming in through pilot air jet ④. This mixture, rich with fuel, then goes up through pilot passage to pilot screw ⑤. A part of the mixture is discharged into the main bore out of bypass ports ⑥. The remainder is then metered by pilot screw ⑤ and sprayed out into the main bore through pilot outlet ⑦.



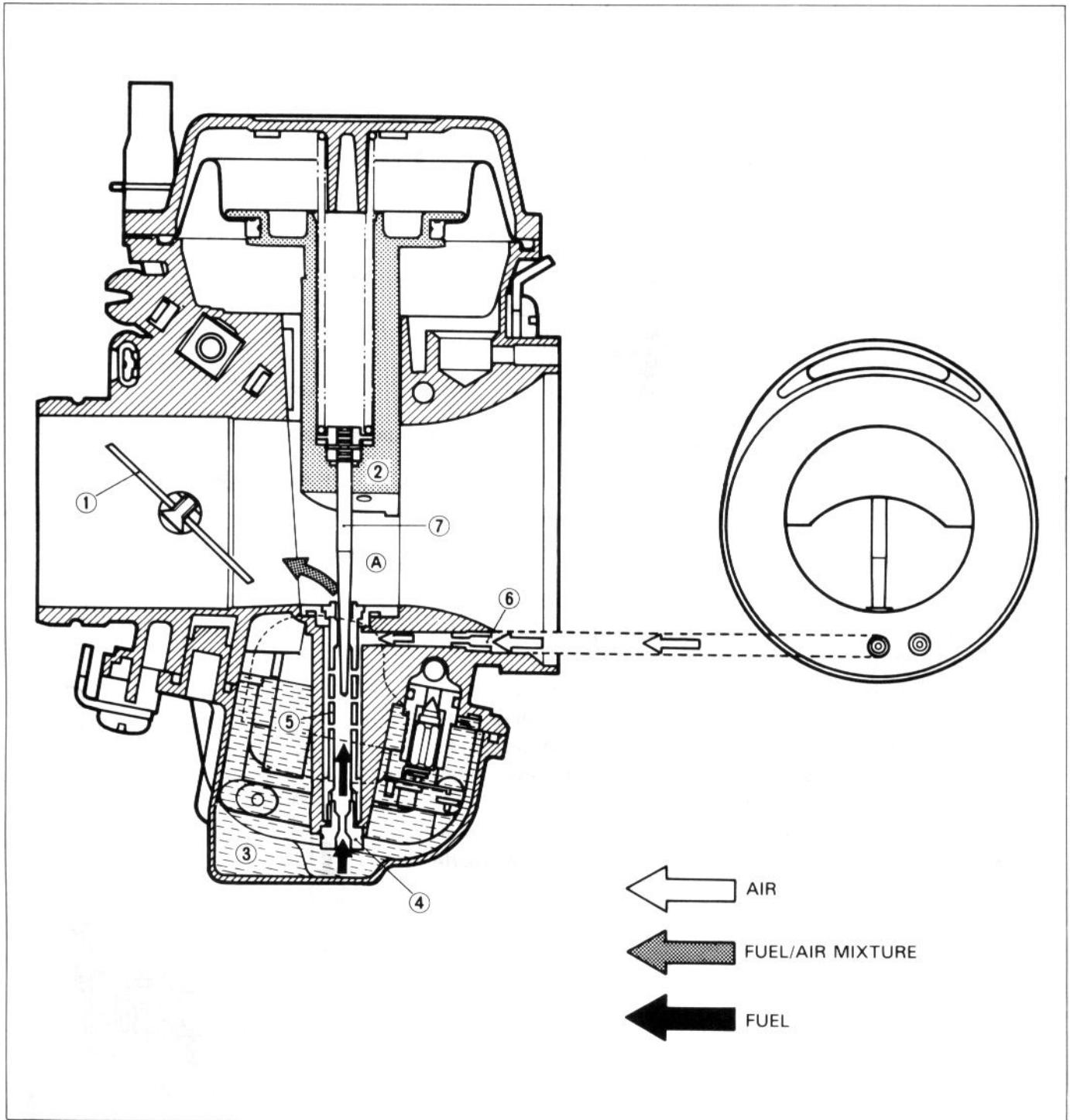
MAIN SYSTEM

As throttle valve ① is opened, engine speed rises, and this increases negative pressure in the venturi ⑧. Consequently the piston valve ② moves upward.

Meanwhile, the fuel in float chamber ③ is metered by main jet ④, and the metered fuel enters needle jet ⑤, in which it mixes with the air admitted through main air jet ⑥ to form an emulsion.

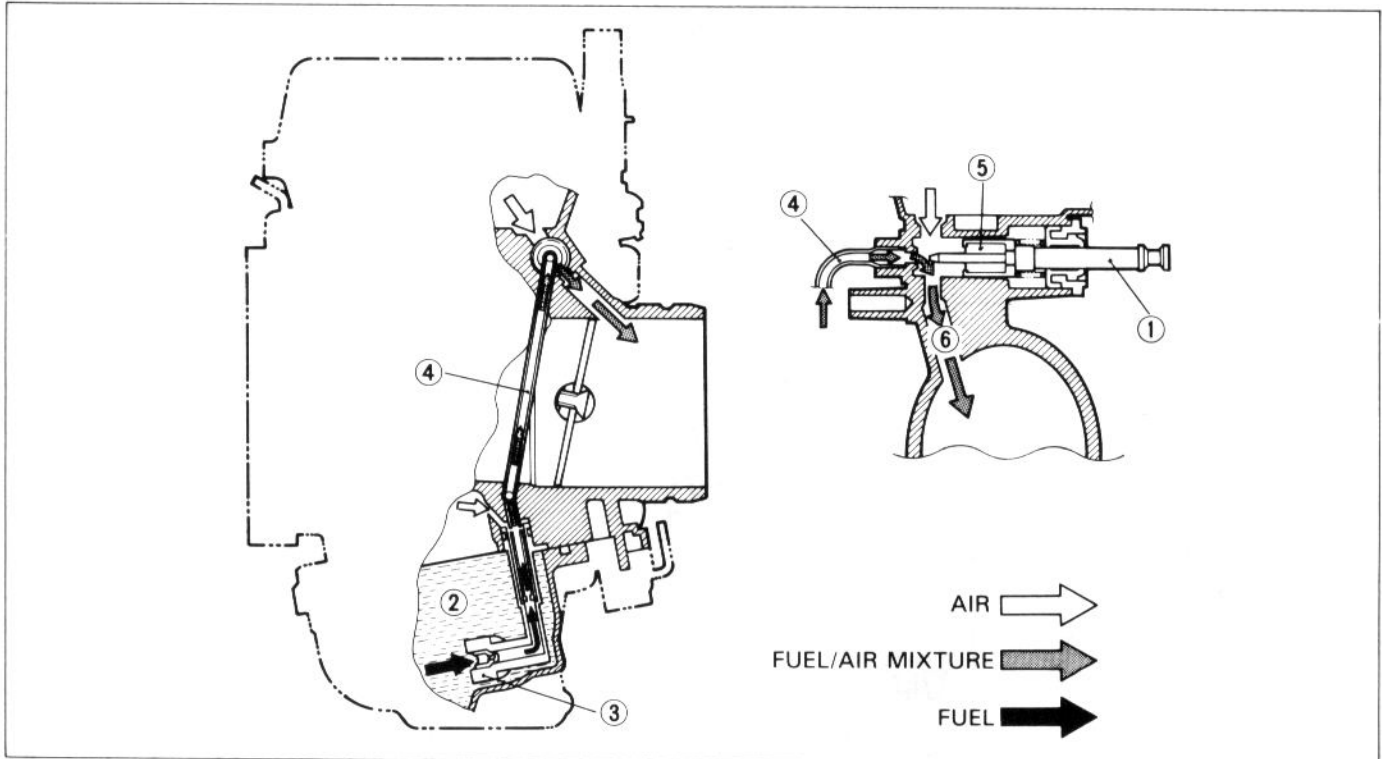
The emulsified fuel then passes through the clearance between needle jet ⑤ and jet needle ⑦, and is discharged into the venturi ⑧, in which it meets main air stream being drawn by the engine.

Mixture proportioning is accomplished in needle jet ⑤; the clearance through which the emulsified fuel must flow in large or small, depending ultimately on throttle position.



STARTER SYSTEM

Pulling up the starter shaft ①, fuel is drawn into the starter circuit from the float chamber ②. Starter jet ③ meters this fuel, which then flows into starter pipe ④ and mixes with the air coming from the float chamber ②. The mixture, rich in fuel content, reaches starter plunger ⑤ and mixes again with the air coming through a passage extending from behind the diaphragm. The two successive mixings of fuel with air are such that proper fuel/air mixture for starting is produced when the mixture is sprayed out through starter outlet ⑥ into the main bore.

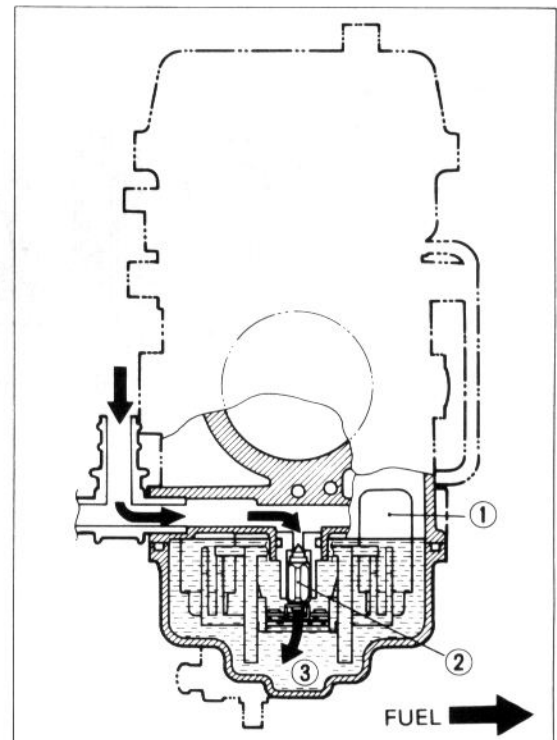


FLOAT SYSTEM

Floats ① and needle valve ② are associated with the same mechanism, so that, as the floats ① move up and down, the needle valve ② too moves likewise.

When fuel level is up in float chamber ③, floats ① are up and needle valve ② remains pushed up against valve seat. Under this condition, no fuel enters the float chamber ③. As the fuel level falls, floats ① go down and needle valve ② unseats itself to admit fuel into the chamber ③.

In this manner, needle valve ② admits and shuts off fuel alternately to maintain a practically constant fuel level inside the float chamber ③.



REMOVAL

Refer to page 3-5.

DISASSEMBLY

Disassemble the carburetor as shown in the illustration on page 4-3.

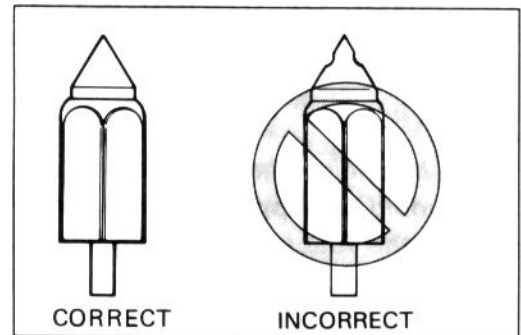
INSPECTION AND ADJUSTMENT

Check following items for any damage or clogging.

- * Pilot jet
- * Main jet
- * Main air jet
- * Pilot air jet
- * Needle jet air bleeding hole
- * Float
- * Needle valve
- * Starter jet
- * Gasket and O-ring
- * Throttle shaft oil seal
- * Diaphragm
- * Pilot outlet and by-pass holes

NEEDLE VALVE INSPECTION

If foreign matter is caught between the valve seat and the needle, the gasoline will continue flowing and cause it to overflow. If the seat and needle are worn beyond the permissible limits, similar trouble will occur. Conversely, if the needle sticks, the gasoline will not flow into the float chamber. Clean the float chamber and float parts with gasoline. If the needle is worn as shown in the illustration, replace it together with a valve seat. Clean the fuel passage of the mixing chamber with compressed air.



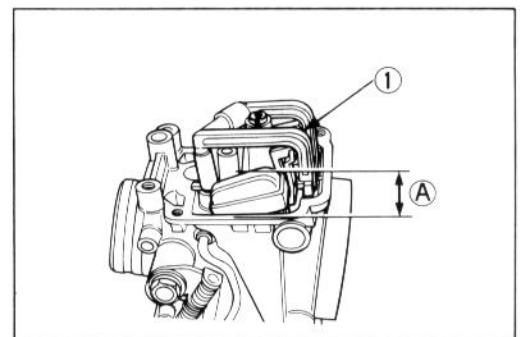
FLOAT HEIGHT ADJUSTMENT

To check the float height, invert the carburetor body, with the float arm kept free, measure the height \textcircled{A} while float arm is just in contact with needle valve by using calipers.

Bend the tongue $\textcircled{1}$ as necessary to bring the height \textcircled{A} to this value.

Float height \textcircled{A} : $14.6 \pm 1.0 \text{ mm}$ ($0.57 \pm 0.04 \text{ in}$)

09900-20102 : Vernier calipers

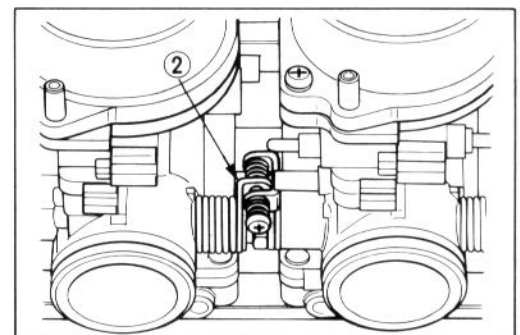


REASSEMBLY AND REMOUNTING

Reassemble and remount the carburetor assembly in the reverse order of disassembly and removal.

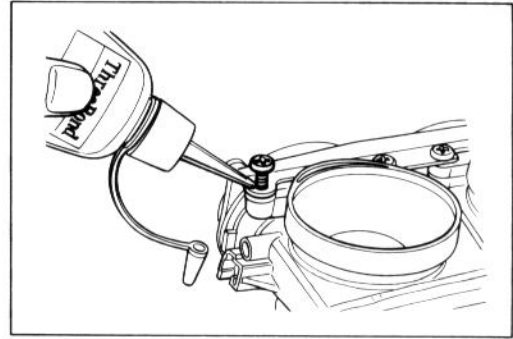
Pay attention to the following points:

- When engaging two carburetors, position the throttle valve control lever $\textcircled{2}$ correctly.

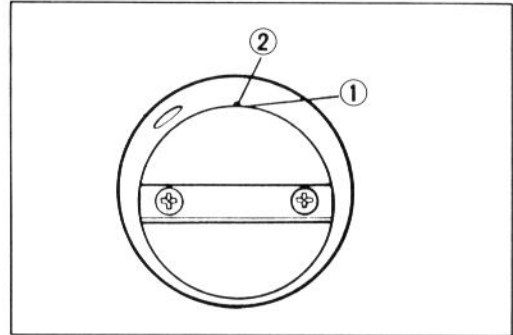


- Apply THREAD LOCK "1342" to the upper and lower plates' screws.

99000-32050: THREAD LOCK "1342"



- Set each throttle valve in such a way that its top end ① meets the foremost by-pass ②. This is accomplished by turning the throttle stop screw and throttle valve balance screw.
- After all work is completed, mount the carburetors on the engine and the following adjustments are necessary.
 - * Engine idle r/min Page 2- 9
 - * Throttle cable play Page 2- 9
 - * Balancing carburetors Page 4-12



BALANCE OF CARBURETORS

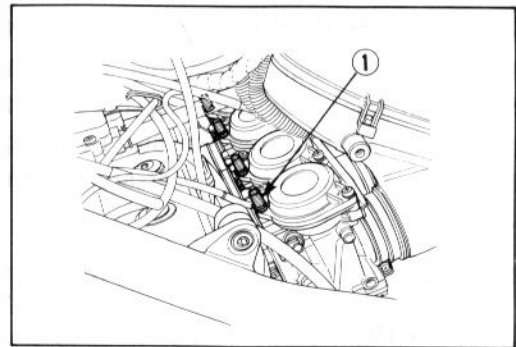
Check the four carburetors for balancing movement according to the following procedures.

NOTE:

When balancing the carburetors, remove the fuel tank and fuel should be supplied by a separate fuel tank and be sure to plug the fuel cock vacuum line.

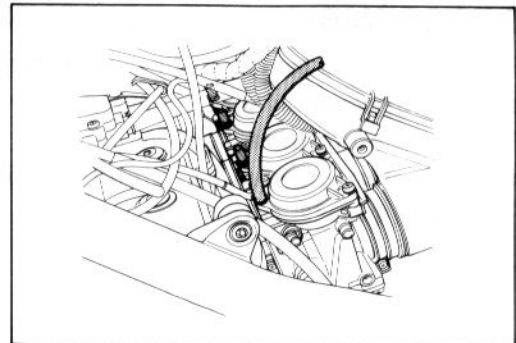
CALIBRATING EACH GAUGE

- Start up the engine and run it in idling condition for warming up.
- Stop the warmed-up engine.
- Remove the vacuum inlet cap ① for No. 1 or No. 4 cylinder.

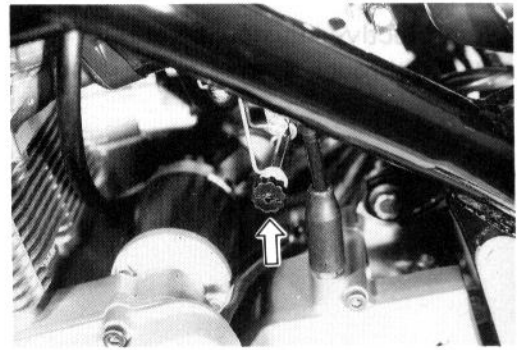


- Connect one of the four rubber hoses of balancer gauge to this inlet.

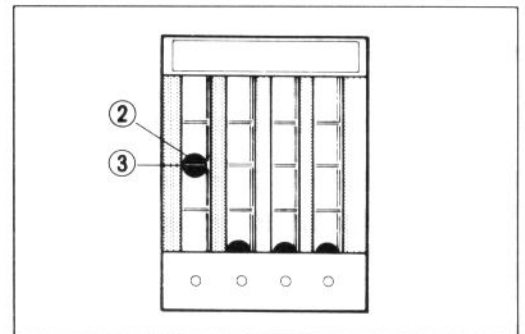
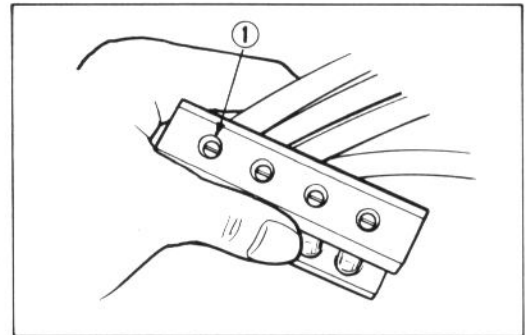
09913-13121 : Carburetor balancer



- Start up the engine and keep it running at 1 750 r/min by turning throttle stop screw.

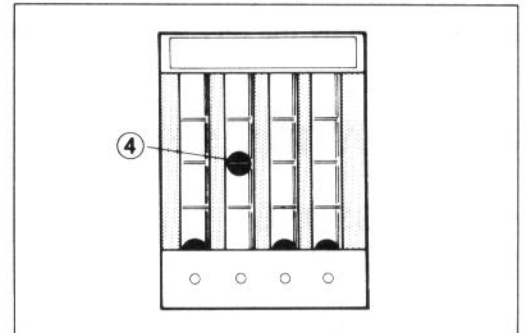


- Turn the air screw ① of the gauge so that the vacuum acting on the tube of that hose will bring the steel ball ② in the tube to the center line ③.



- After making sure that the steel ball stays steady at the center line, disconnect the hose from inlet and connect the next hose to the inlet.
- Turn air screw to bring the other steel ball ④ to the center line.
- Repeat the above process on the third and fourth hoses.

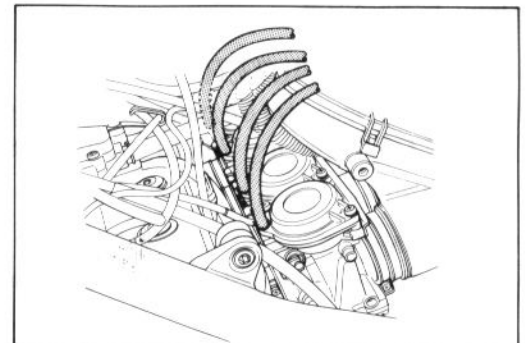
The balancer gauge is now ready for use in balancing the carburetors.



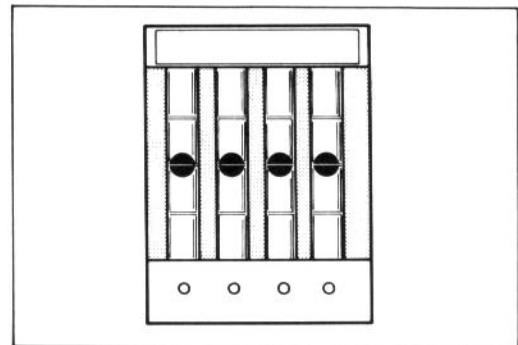
BALANCING CARBURETORS

For balancing all the carburetor movement, remove all the vacuum inlet caps from each carburetor. Connect the balancer gauge hoses to these vacuum inlets and adjust the balance of four carburetors as follows:

- Start up the engine and keep it running at 1 750 r/min to see engine tachometer reading.



A correctly adjusted carburetor has the steel balls in the Nos. 1 through 4 tubes at the same level.



- If the steel balls are not in correct positions, adjust the throttle valve balance screws correctly.
- Adjusting order is as follows.



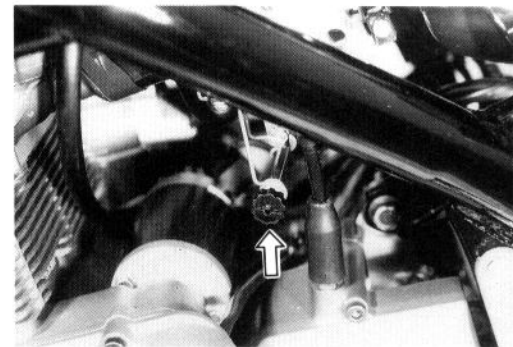
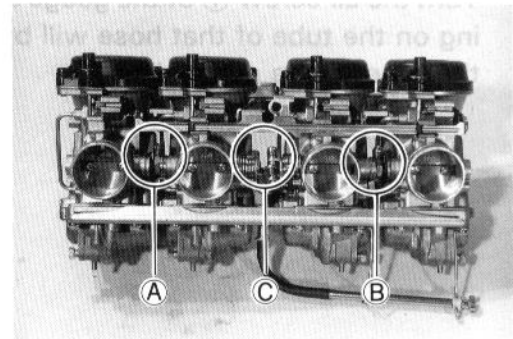
- After balancing the carburetors, set there speed between 1350 and 1450 r/min. by turning the throttle stop screw referring engine tachometer reading.

Idle r/min: 1400 ± 50 r/min for E03, 22 and 33.
: 1300 ± 100 r/min for the others

E-03: U.S.A., E-22: W. Germany, E-33: California (U.S.A.)

CAUTION:

Do not disturb the pilot screw. This component is PRE-SET at the factory by the very specialized equipment.



LUBRICATION SYSTEM

OIL PRESSURE

Refer to page 3-2.

OIL FILTER

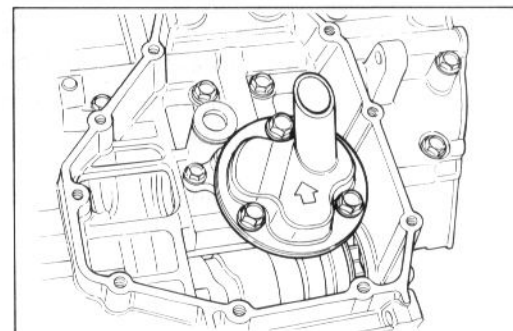
Refer to page 2-8.

OIL SUMP FILTER

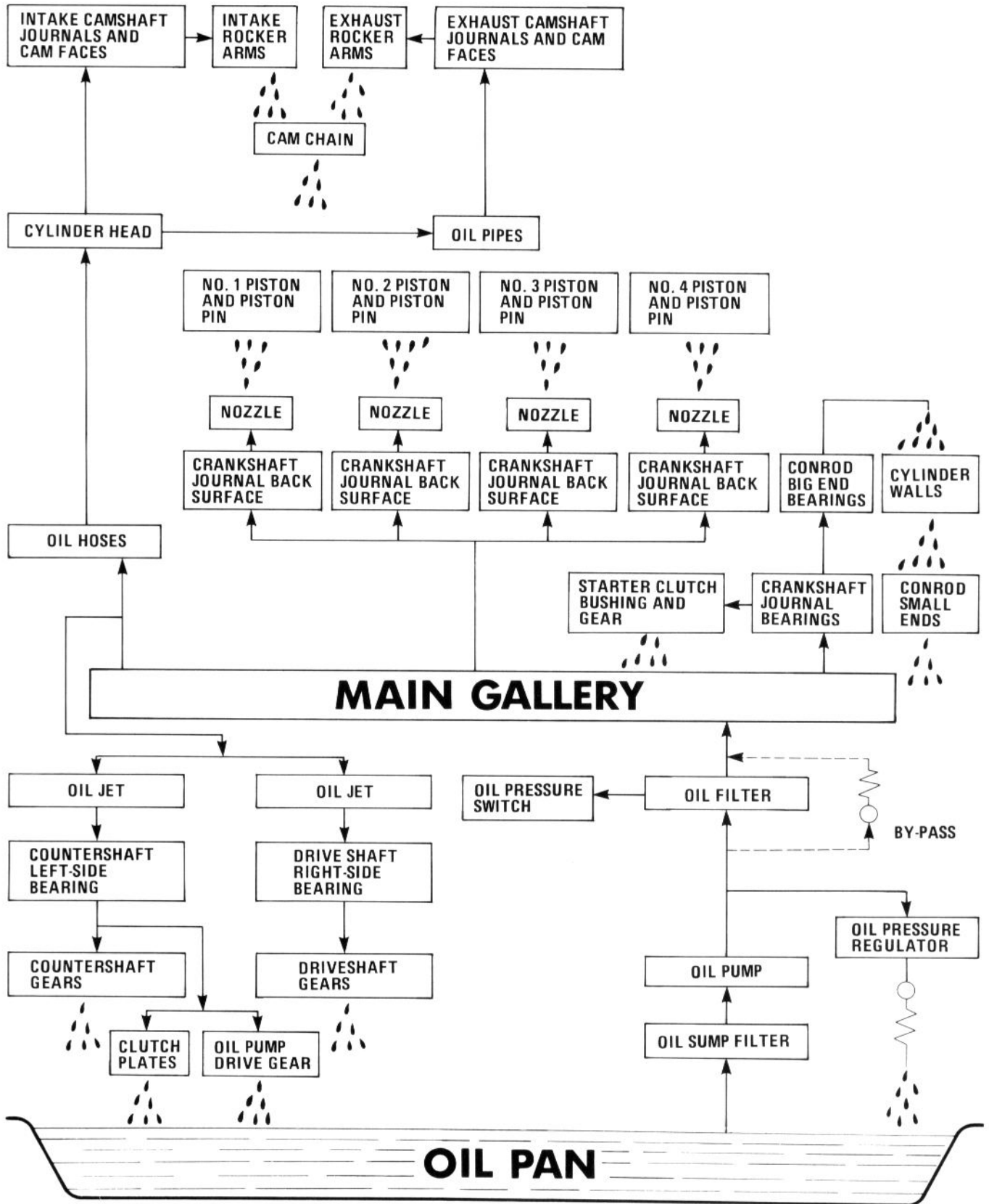
When you wash the oil pan, check to be sure that the oil sump filter is free from any sign of rupture, also wash the filter clean periodically.

CAUTION:

Replace the oil pan gasket with a new one to prevent oil leakage.



LUBRICATION SYSTEM CHART



COOLING SYSTEM

CONTENTS

COOLING SYSTEM	5- 1
DESCRIPTION	5- 1
CONSTRUCTION	5- 2
COOLING SOLUTION	5- 4
COOLING SYSTEM REMOVAL AND DISASSEMBLY	5- 5
RADIATOR	5- 5
COOLING FAN	5- 6
WATER THERMO-SWITCH AND COOLING FAN	
THERMO-SWITCH	5- 6
THERMOSTAT	5- 7
WATER PUMP	5- 7
RADIATOR	5- 9
INSPECTION	5- 9
REMOVAL	5- 9
INSTALLATION	5- 9
WATER THERMO-SWITCH	5-10
REMOVAL	5-10
INSPECTION	5-10
REASSEMBLY	5-10
COOLING FAN	5-10
REMOVAL	5-10
INSPECTION	5-10
COOLING FAN THERMO-SWITCH	5-11
REMOVAL	5-11
INSPECTION	5-11
REASSEMBLY	5-11
THERMOSTAT	5-12
REMOVAL	5-12
INSPECTION	5-12
REASSEMBLY	5-12
WATER PUMP	5-13
REMOVAL AND DISASSEMBLY	5-13
INSPECTION	5-13
REASSEMBLY	5-13

COOLING SYSTEM

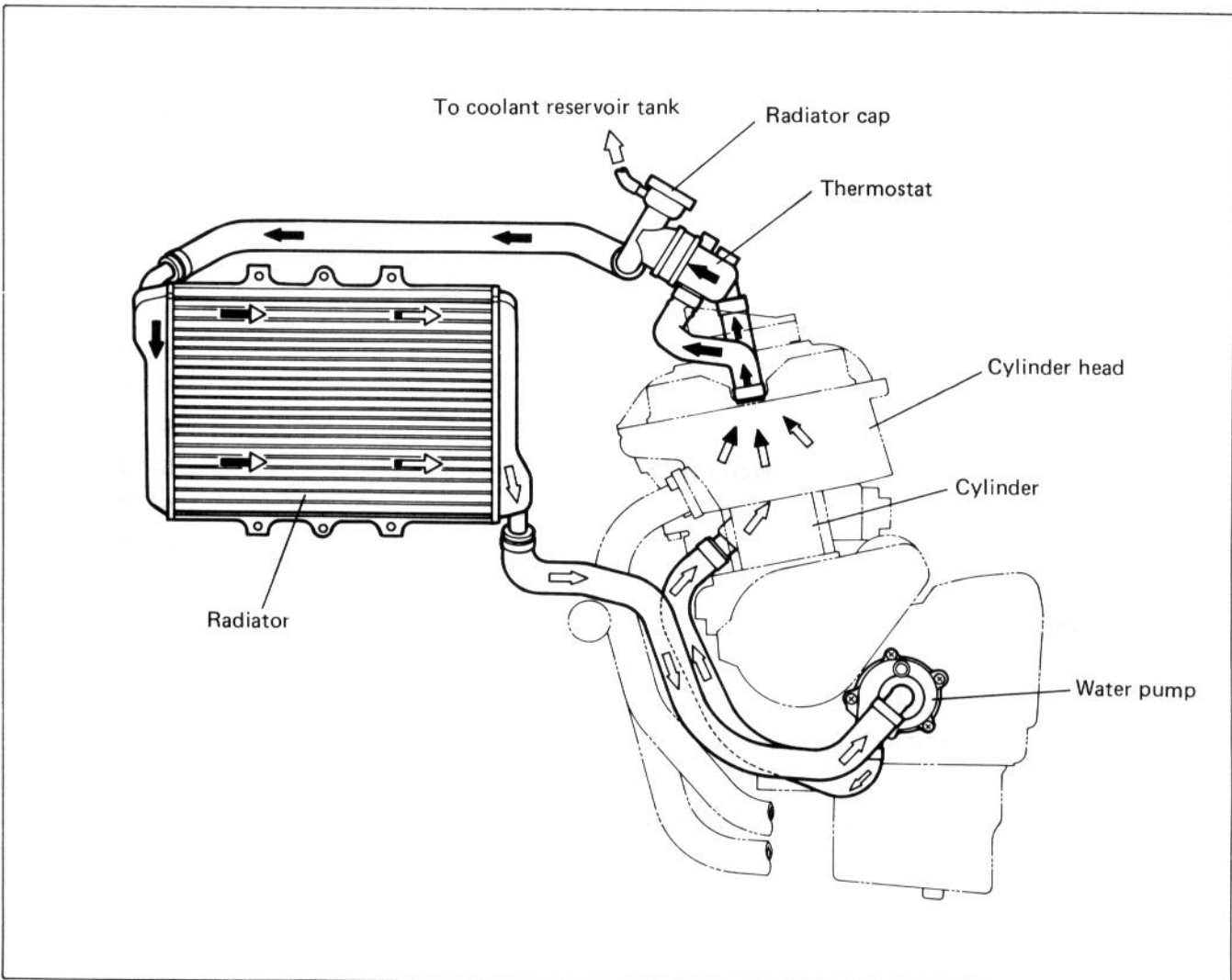
DESCRIPTION

The engine is cooled by coolant set in forced recirculation through jackets formed in the cylinder and cylinder head, and through the radiator. For the water pump, a high-capacity centrifugal pump is used. The radiator is a tube-and-fin type made of aluminum material, which is characterized by lightness in weight and good heat dissipation.

The thermostat is of wax pellet type, complete with a valve as the means of temperature-dependent control over the flow of coolant through the radiator. The valve is actuated by the temperature-sensitive wax contained in the pellet.

Referring to the following illustration, the thermostat is in the closed condition, so that coolant recirculates through the route comprising pump, engine, by-pass hole of the thermostat and radiator in the regulated condition.

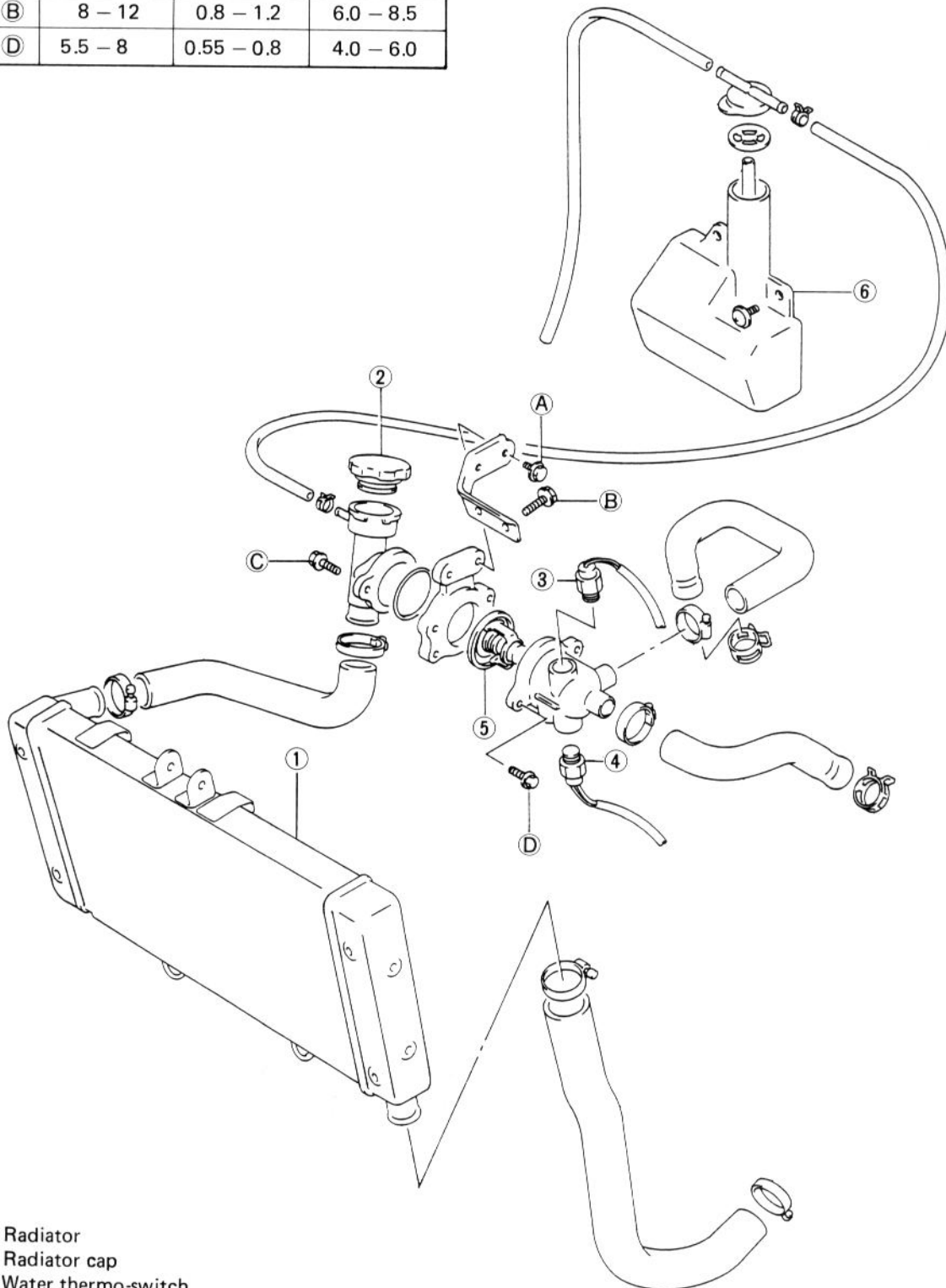
As the coolant temperature rises to 76.5°C and the thermostat valve unseats, the normal coolant flow is established. At about 90°C of coolant temperature, the thermostat becomes completely open and most of heat is released to the atmosphere through the radiator core.



CONSTRUCTION

Tightening torque

ITEM	N·m	kg·m	lb·ft
(A) (B)	8 – 12	0.8 – 1.2	6.0 – 8.5
(C) (D)	5.5 – 8	0.55 – 0.8	4.0 – 6.0



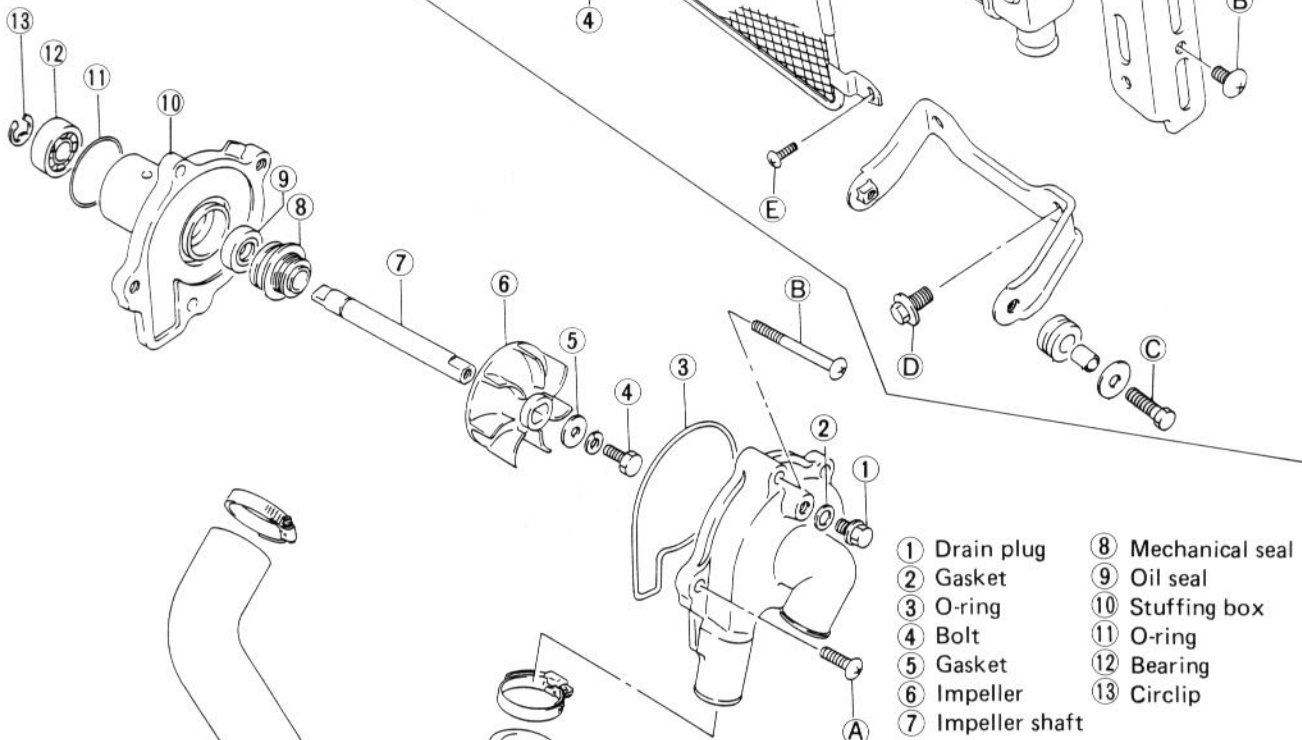
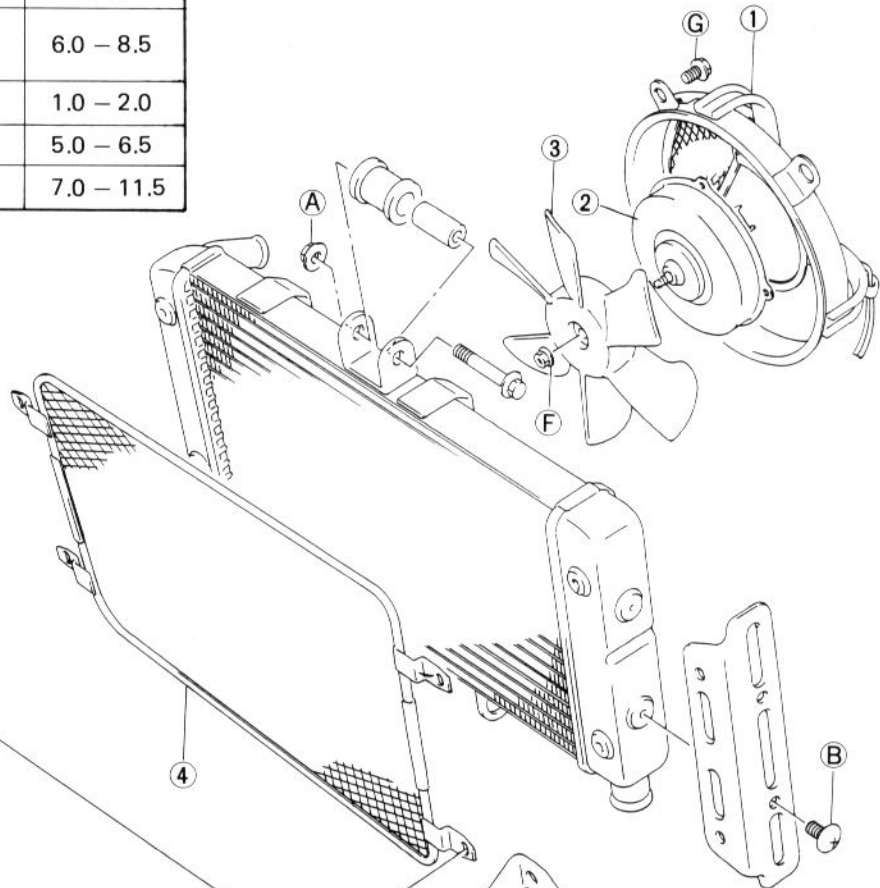
- ① Radiator
- ② Radiator cap
- ③ Water thermo-switch
- ④ Cooling fan thermo-switch
- ⑤ Thermostat
- ⑥ Coolant reservoir

5-3 COOLING SYSTEM

Tightening torque

ITEM	N-m	kg-m	lb-ft
A B C G	8 - 12	0.8 - 1.2	6.0 - 8.5
E	1.5 - 3	0.15 - 0.3	1.0 - 2.0
F	7 - 9	0.7 - 0.9	5.0 - 6.5
D	10 - 16	1.0 - 1.6	7.0 - 11.5

- ① Shroud
- ② Fan motor
- ③ Cooling fan
- ④ Stone guard net



- ① Drain plug
- ② Gasket
- ③ O-ring
- ④ Bolt
- ⑤ Gasket
- ⑥ Impeller
- ⑦ Impeller shaft
- ⑧ Mechanical seal
- ⑨ Oil seal
- ⑩ Stuffing box
- ⑪ O-ring
- ⑫ Bearing
- ⑬ Circlip

Tightening torque

ITEM	N-m	kg-m	lb-ft
A B	7 - 11	0.7 - 1.1	5.0 - 8.0
①	10 - 14	1.0 - 1.4	7.0 - 10
④	7 - 9	0.7 - 0.9	5.0 - 6.5

COOLING SOLUTION

At the time of manufacture, the cooling system is filled with a 50 : 50 solution of distilled water and anti-freeze/summer coolant. This 50 : 50 mixture will provide excellent heat protection, and will protect the cooling system from freezing at temperatures above -31°C (-24°F).

If the motorcycle is to be exposed to temperatures below -31°C (-24°F), this mixing ratio should be increased up to 55% or 60% according to the Fig. 2.

NOTE:

The characteristics of different anti-freezes vary. Read the label to know the protection you will have.

CAUTION:

Do not put in more than 60% anti-freeze or less than 50%. Do not mix different brands of anti-freeze.

50%	Water	950 ml (2.0/1.7 US/Imp. pt)
	Coolant	950 ml (2.0/1.7 US/Imp. pt)

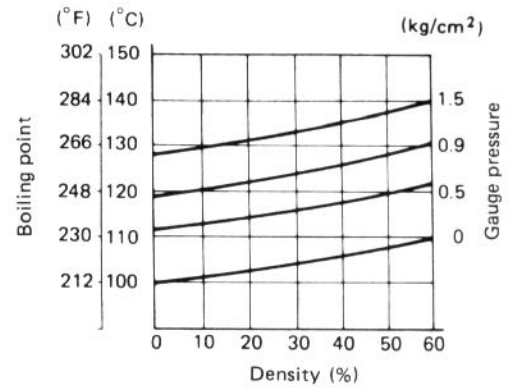


Fig. 1 Coolant density-boiling point curve.

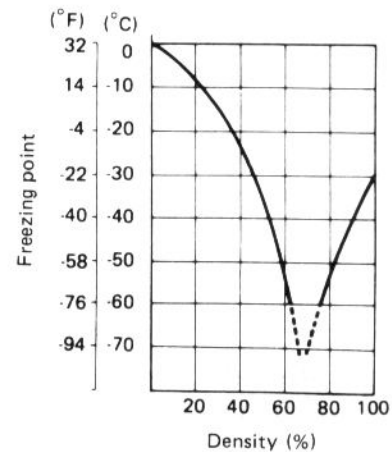
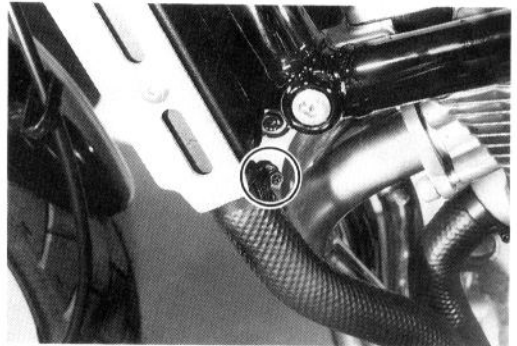
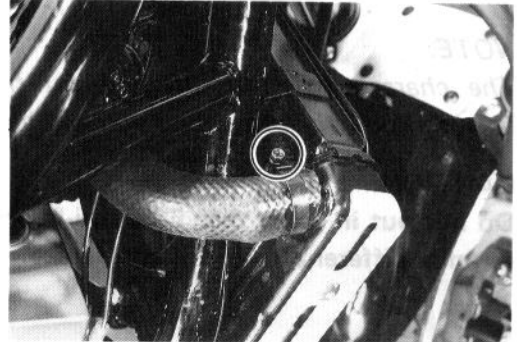
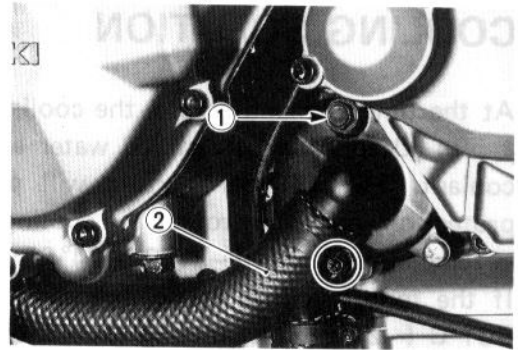


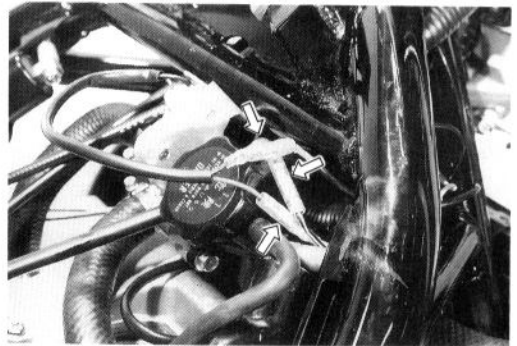
Fig. 2 Coolant density-freezing point curve.

COOLING SYSTEM REMOVAL AND DISASSEMBLY

- Remove the front seat. (Refer to page 1-12.)
- Remove the left and right air cleaner side cover. (Refer to page 1-12.)
- Remove the fuel tank. (Refer to page 4-2.)
- Drain the coolant by removing the drain plug ① and disconnect the water hose ② by loosening the clamp screw.
- Loosen the clamp screws and disconnect water hoses from the radiator.

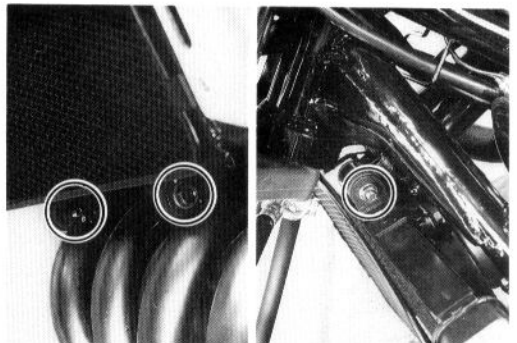


- Disconnect the water thermo-switch lead wires and cooling fan thermo-switch lead wires.



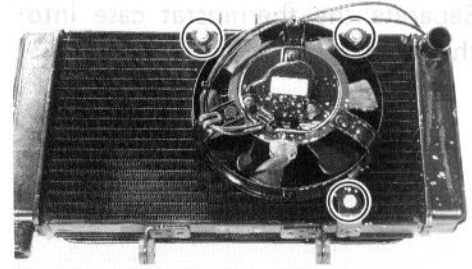
RADIATOR

- Remove the radiator by removing the mounting bolts.

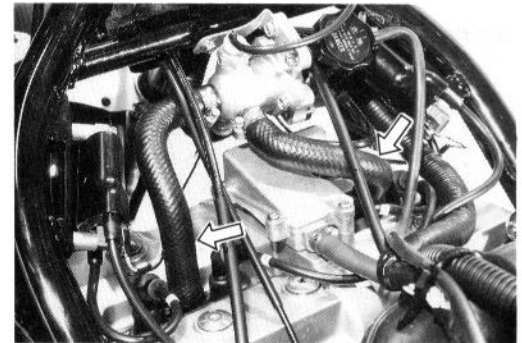


COOLING FAN

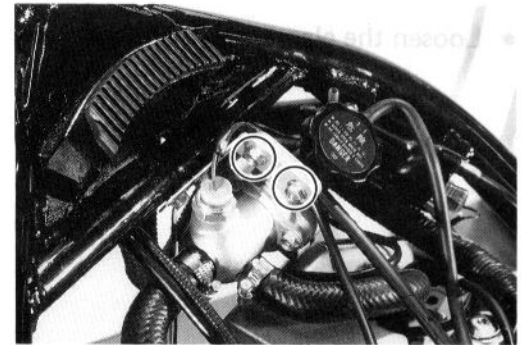
- Remove the cooling fan.



- Loosen the clamp screws and disconnect water hoses from the cylinder head.

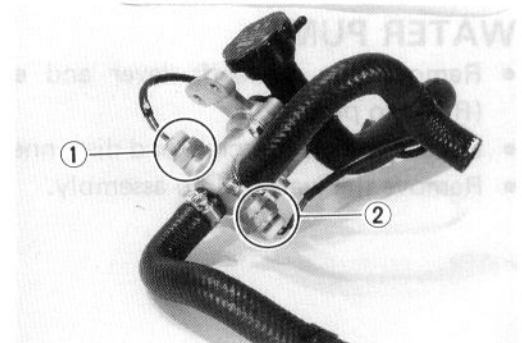


- Remove the thermostat case along with the water hoses.

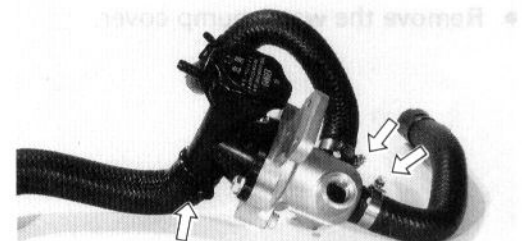


WATER THERMO-SWITCH AND COOLING FAN THERMO-SWITCH

- Remove the water thermo-switch ① and cooling fan thermo-switch ②.



- Loosen the clamp screws and disconnect the water hoses.

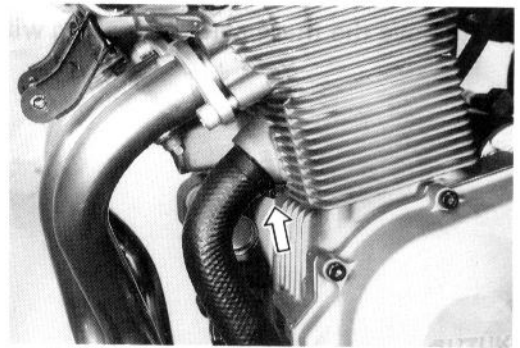


THERMOSTAT

- Separate the thermostat case into halves and remove the thermostat.

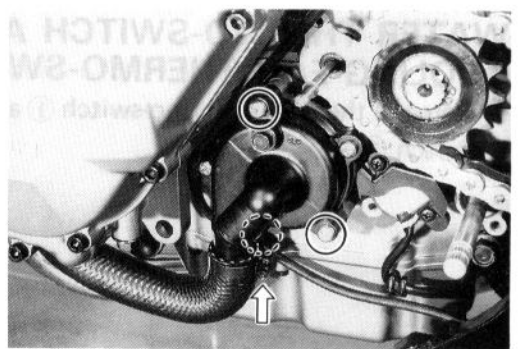


- Loosen the clamp screw and disconnect the water hose.

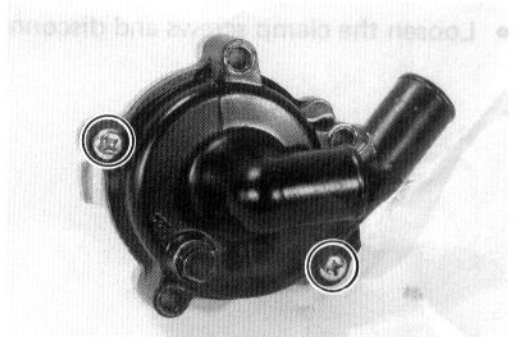


WATER PUMP

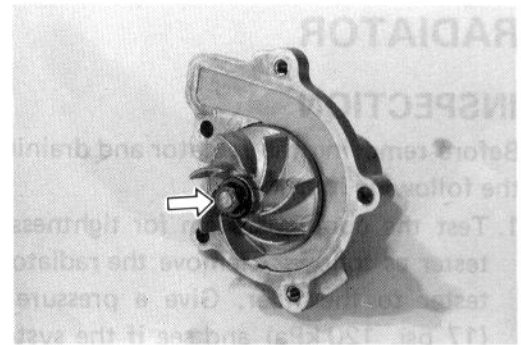
- Remove the gearshift lever and engine sprocket cover. (Refer to page 3-6.)
- Loosen the clamp screw and disconnect the water hose.
- Remove the water pump assembly.



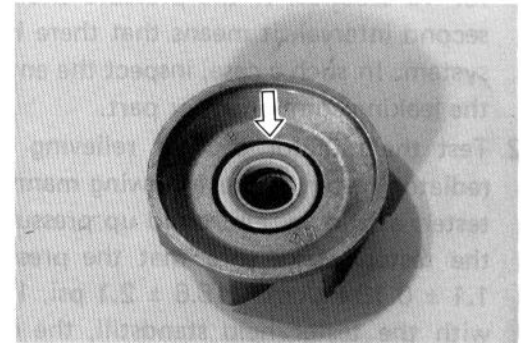
- Remove the water pump cover.



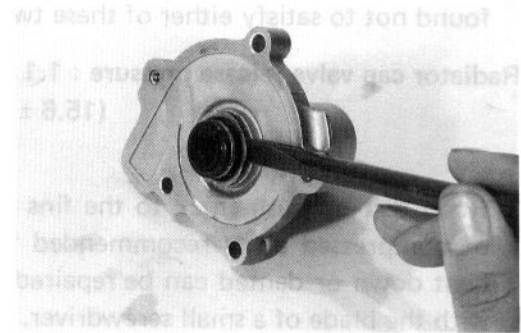
- Remove the impeller securing bolt by holding the impeller shaft with a water pump pliers.



- Remove the mechanical seal ring.



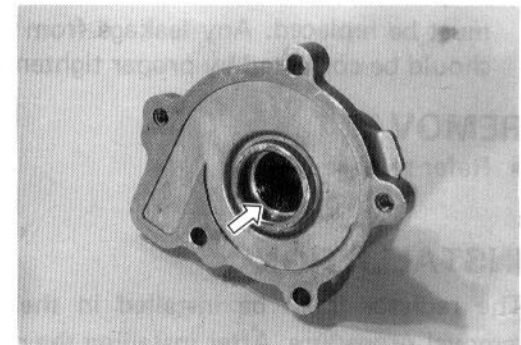
- Remove the circlip from the impeller shaft.
- Remove the impeller shaft.
- Remove the mechanical seal.



- Remove the oil seal.

CAUTION:

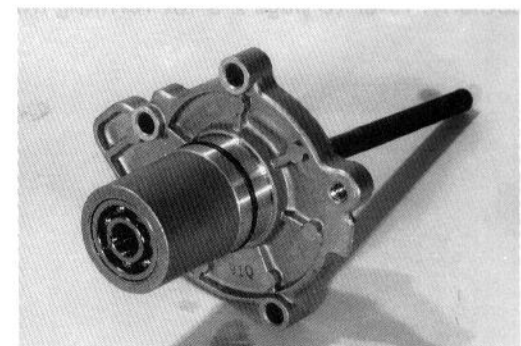
The removed mechanical seal or oil seal should be replaced with a new one.



- Drive out the bearing using a suitable bar.

CAUTION:

The removed bearing should be replaced with a new one.



RADIATOR

INSPECTION

Before removing the radiator and draining the coolant, inspect the following items.

1. Test the cooling system for tightness by using the radiator tester as follows: Remove the radiator cap, and connect the tester to the filler. Give a pressure of about 1.2 kg/cm^2 (17 psi, 120 kPa) and see if the system holds this pressure for 10 seconds. If the pressure should fall during this 10-second interval, it means that there is a leaking point in the system. In such a case, inspect the entire system and replace the leaking component or part.
2. Test the radiator cap for relieving pressure by using the radiator tester in the following manner: Fit the cap to the tester, as shown, and build up pressure slowly by operating the tester. Make sure that the pressure build-up stops at $1.1 \pm 0.15 \text{ kg/cm}^2$ ($15.6 \pm 2.1 \text{ psi}$, $110 \pm 15 \text{ kPa}$) and that, with the tester held standstill, the cap is capable of that pressure for at least 10 seconds. Replace the cap if it is found not to satisfy either of these two requirements.

**Radiator cap valve release pressure : $1.1 \pm 0.15 \text{ kg/cm}^2$
($15.6 \pm 2.1 \text{ psi}$, $110 \pm 15 \text{ kPa}$)**

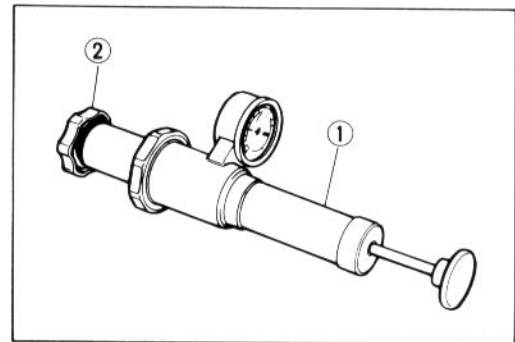
3. Road dirt or trash stuck to the fins must be removed. Use of compressed air is recommended for this cleaning. Fins bent down or dented can be repaired by straightening them with the blade of a small screwdriver.
4. Any water hose found in a cracked condition or flattened must be replaced. Any leakage from the connecting section should be corrected by proper tightening.

REMOVAL

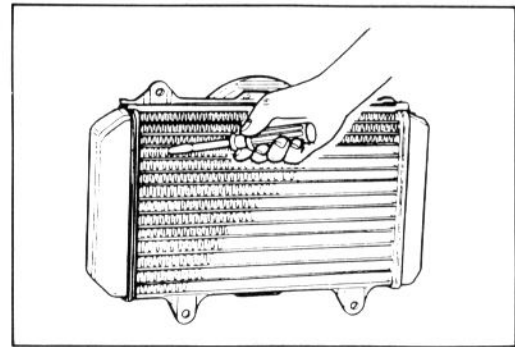
- Refer to page 5-5.

INSTALLATION

The radiator is to be installed in the reverse order of the removal procedure. After installing the radiator, be sure to add coolant: refer to page 2-9 for refilling information.



① Radiator cap tester ② Radiator cap



WATER THERMO-SWITCH

REMOVAL

- Refer to page 5-6.

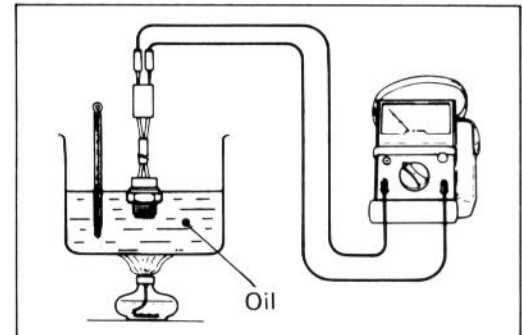
INSPECTION

The water thermo-switch must be checked for its temperature-initiated closing action at the specification value of 117°C (243°F) by testing it at the bench as shown in the illustration. Connect the switch to the pocket tester and raise the temperature of the oil in the pan, and read the column thermometer when the switch closes.

09900-25002 : Pocket tester

Water thermo-switch specification

OFF → ON	Approx. 117°C (243°F)
ON → OFF	Approx. 110°C (230°F)



REASSEMBLY

NOTE:

Do not forget the new O-ring.

Tightening torque

Water thermo-switch : 9.0 – 14 N·m
(0.9 – 1.4 kg·m, 6.5 – 10.0 lb-ft)

CAUTION:

Take special care when handling the water thermo-switch. It may cause damage if water thermo-switch gets a sharp impact. Replace the O-ring with a new one.

- Fill the specified coolant (See page 2-9).

COOLING FAN

REMOVAL

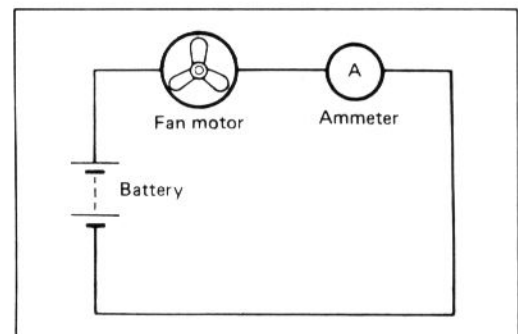
- Refer to page 5-6.

INSPECTION

Test the cooling fan drive motor for load current with an ammeter connected as shown in the illustration.

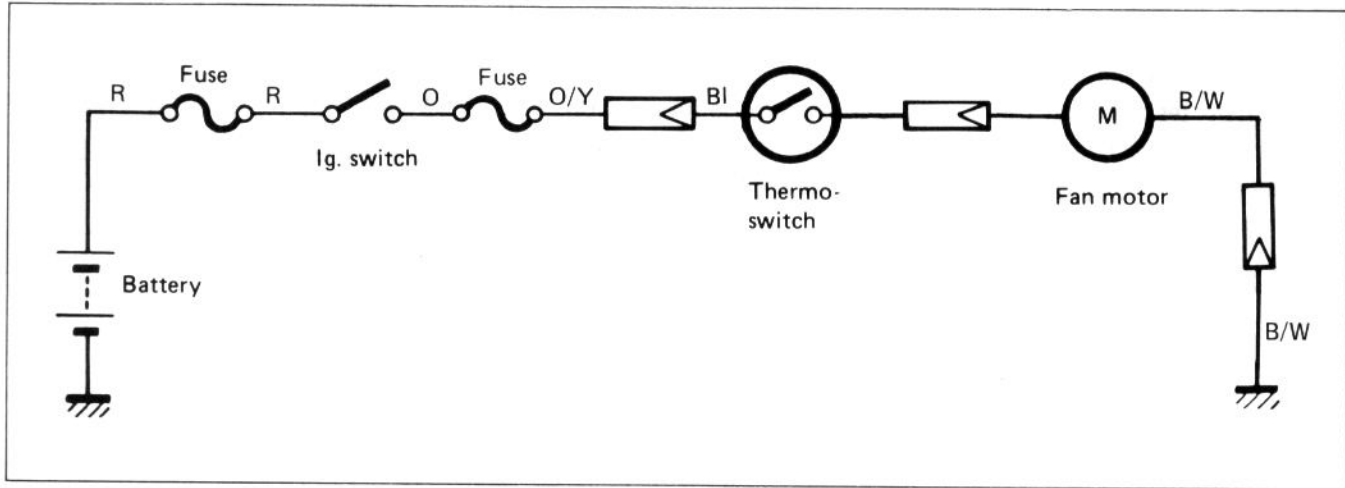
The voltmeter is for making sure that the battery applies 12 volts to the motor. With the motor with electric motor fan running at full speed, the ammeter should be indicating not more than 5 amperes.

If the fan motor does not turn, replace the motor assembly with a new one.



COOLING FAN THERMO-SWITCH

The cooling fan, being located behind the radiator, is secured to the radiator by three bolts. The fan drive motor is automatically controlled by the thermo-switch. This switch remains open when the temperature of coolant is low, but it closes at about 95°C (203°F) of rising water temperature to set the fan in motion.



REMOVAL

- Refer to page 5-6.

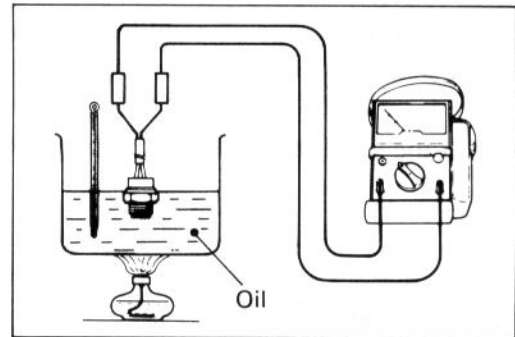
INSPECTION

- The thermo-switch must be checked for its temperature-initiated closing action at the specification value of 95°C (203°F) by testing it at the bench as shown in the figure. Connect the switch to a circuit tester and raise the temperature of the oil in the pan, and read the column thermometer when the switch closes.

09900-25002 : Pocket tester

Thermo-switch specification

OFF → ON	Approx. 95°C (203°F)
ON → OFF	Approx. 88°C (190.4°F)



REASSEMBLY

NOTE:

Do not forget the new O-ring.

Tightening torque

Thermo-switch : 9.0 – 14 N·m
(0.9 – 1.4 kg·m, 6.5 – 10.0 lb·ft)

CAUTION:

Take special care when handling the thermo-switch. It may cause damage if thermo-switch gets a sharp impact.

Replace the O-ring with a new one.

THERMOSTAT

REMOVAL

- Refer to page 5-7.

INSPECTION

Inspect the thermostat pellet for signs of cracking.

Test the thermostat at the bench for control action, in the following manner.

- Pass a string between flange, as shown in the illustration.
- Immerse the thermostat in the water contained in a beaker, as shown in the illustration. Note that the immersed thermostat is in suspension. Heat the water by placing the beaker on a stove and observe the rising temperature on a thermometer.
- Read the thermometer just when the thermostat drops to the bottom of the pan. This reading, which is the temperature level at which the thermostat valve begins to open, should be anywhere between 74.5°C (166.1°F) and 78.5°C (173.3°F).

**Thermostat valve opening temperature : 74.5 – 78.5°C
(166.1 – 173.3°F)**

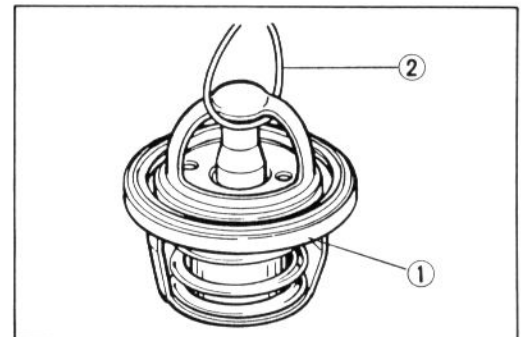
- Keep on heating the water to raise its temperature to and beyond 90°C (194°F).
- Just when the water reaches 90°C (194°F), the thermostat valve should have lifted by at least 7.0 mm (0.28 in).

**Thermostat valve lift : Over 7.0 mm at 90°C
(Over 0.28 in at 194°F)**

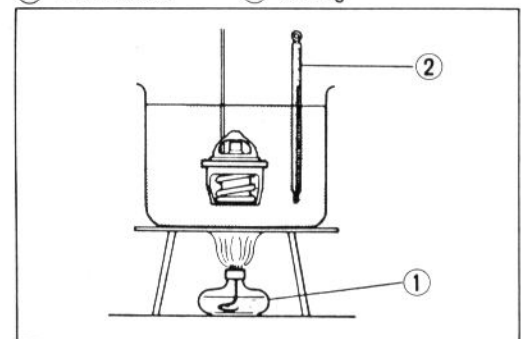
- A thermostat failing to satisfy either of the two requirements (start-to-open temperature and valve lift) must be replaced.

REASSEMBLY

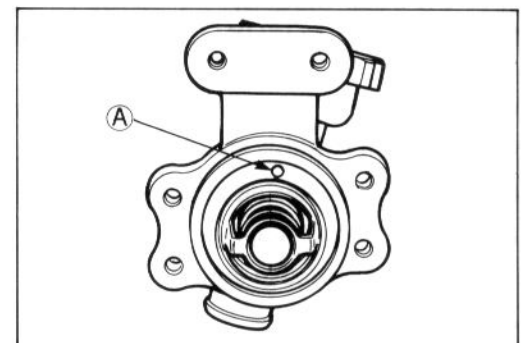
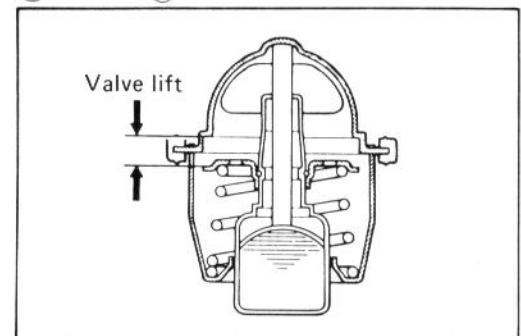
- The air bleeder hole (A) of the thermostat faces upside.



① Thermostat ② String



① Stove ② Thermometer



WATER PUMP

REMOVAL AND DISASSEMBLY

- Refer to page 5-7 for the water pump removal and disassembly procedures.

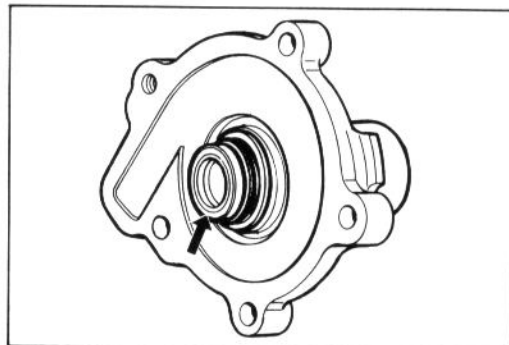
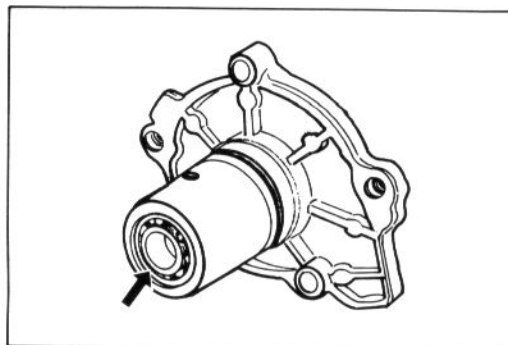
INSPECTION

WATER PUMP BEARING

Turn the inner race and check the bearing play. If abnormal noise occurs or any sign of stickiness is noted, replace the bearing with a new one.

MECHANICAL SEAL

Visually inspect the mechanical seal for damage, with particular attention given to the sealing face. Replace the mechanical seal that shows indications of leakage. Also replace the oil seal if necessary.

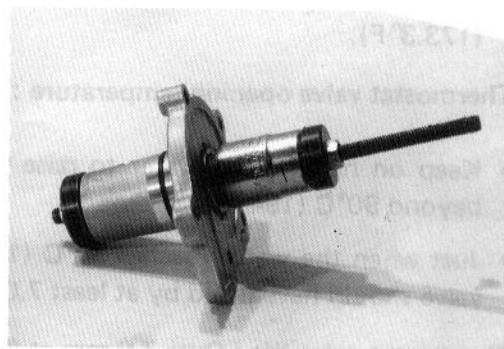


REASSEMBLY

Reassemble and remount the water pump in the reverse order of removal and disassembly. Pay attention to the following points:

- Press the new bearing into the stuffing box with the special tool and a suitable size sleeve etc.

09924-84521: Bearing installer



- Apply grease to the oil seal lip before installing.

(For U.S.A. model)

99000-25030 : SUZUKI SUPER GREASE "A"

(For the other models)

99000-25010 : SUZUKI SUPER GREASE "A"

- Press the new oil seal into the stuffing box with the special tool and a suitable size sleeve etc.

09924-84521: Bearing installer

- Press the new mechanical seal into the stuffing box with a suitable size sleeve etc.

NOTE:

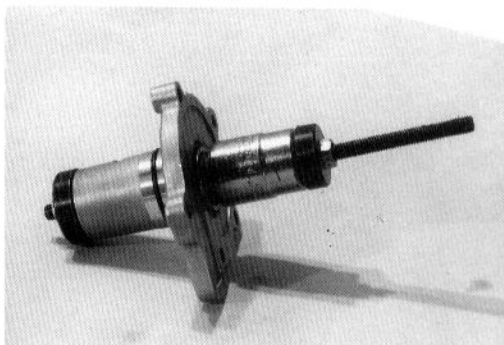
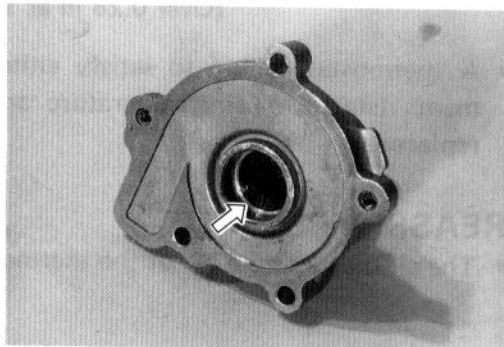
When installing the mechanical seal, apply SUZUKI BOND NO. 1207B to its outer surface.

(For U.S.A. model)

99104-31140: SUZUKI BOND NO. 1207B

(For the other models)

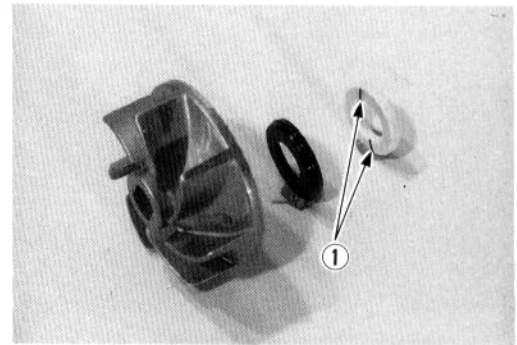
99000-31140: SUZUKI BOND NO. 1207B



- Replace the O-ring and water seal with new ones when re-assembling the water pump.

NOTE:

The mechanical seal ring must be assembled with marked face ① of the ring toward the impeller.



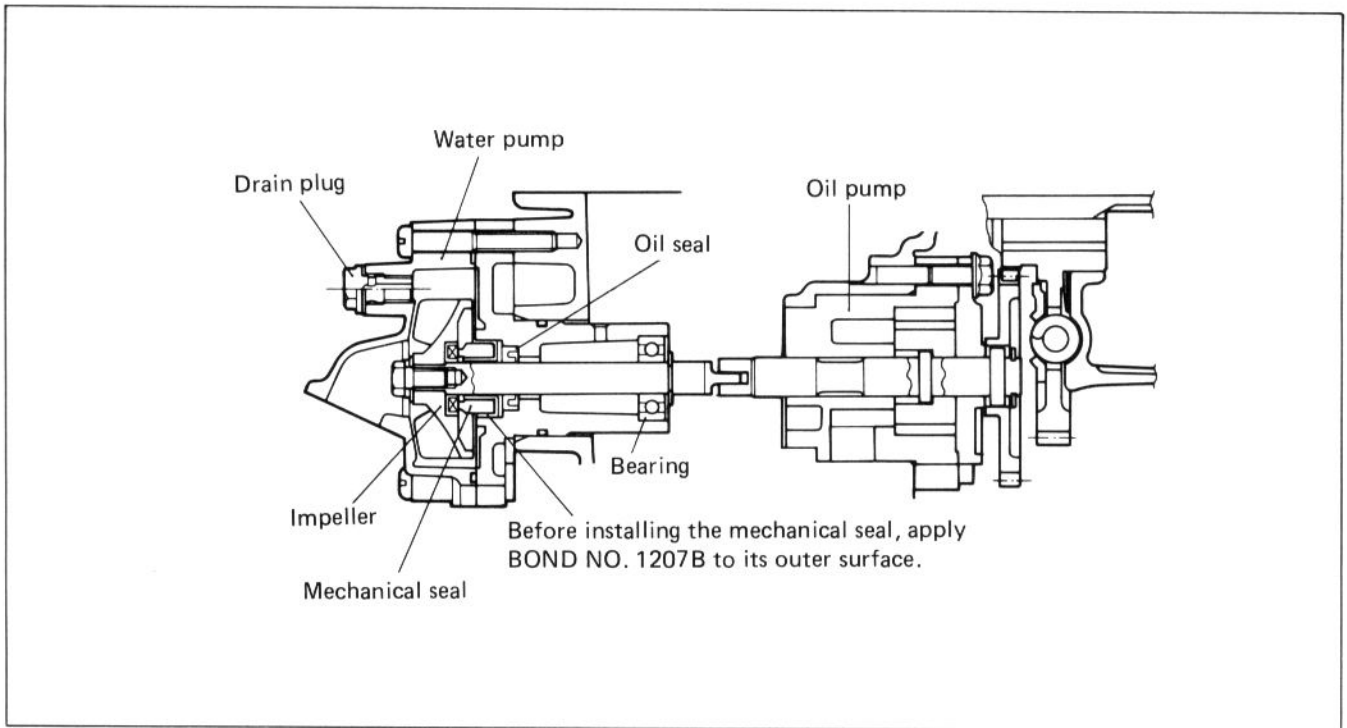
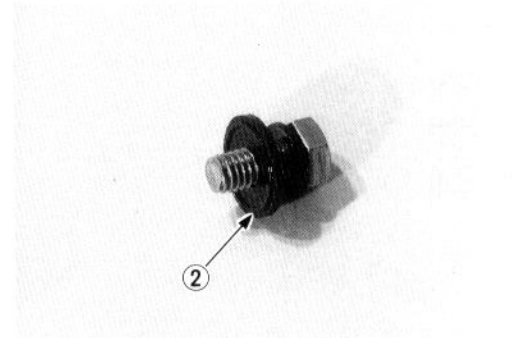
- Tighten the impeller securing bolt to the specified torque.

Tightening torque: 7 – 9 N·m

(0.7 – 0.9 kg·m, 5.0 – 6.5 lb-ft)

NOTE:

The seal lip side ② faces impeller.



Refer to page 8-17 for the radiator hose routing.

ELECTRICAL SYSTEM

CONTENTS

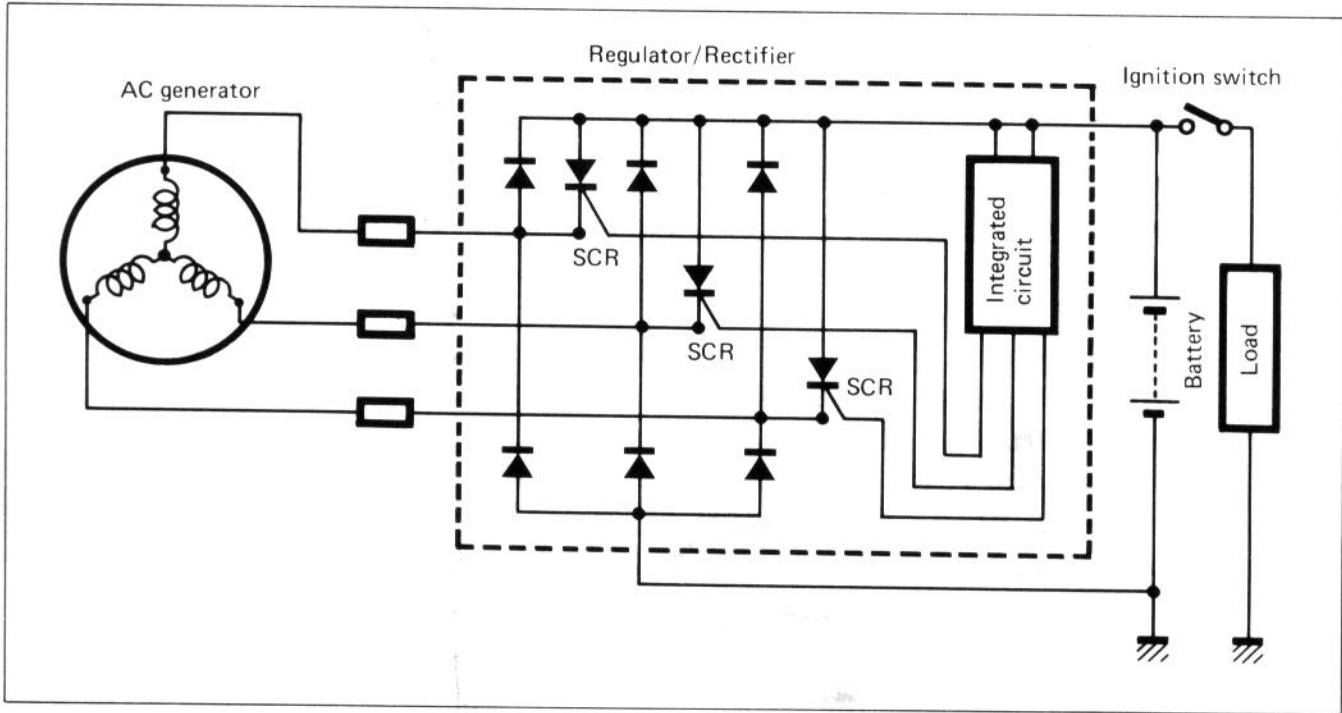
CHARGING SYSTEM	6- 1
DESCRIPTION	6- 1
INSPECTION	6- 3
IGNITION SYSTEM	6- 5
DESCRIPTION	6- 5
INSPECTION	6- 6
STARTER SYSTEM	6-10
DESCRIPTION	6-10
REMOVAL AND DISASSEMBLY	6-10
INSPECTION	6-11
REASSEMBLY	6-12
STARTER RELAY INSPECTION	6-13
SIDE-STAND/IGNITION INTERLOCK SYSTEM	6-13
DESCRIPTION	6-13
INSPECTION	6-15
COMBINATION METER	6-16
REMOVAL AND DISASSEMBLY	6-16
INSPECTION	6-17
LAMPS	6-18
HEADLIGHT	6-18
TAIL/BRAKE LIGHT	6-18
TURN SIGNAL LIGHT	6-19
SWITCHES	6-19
RELAY	6-20
STARTER RELAY	6-20
SIDE-STAND RELAY	6-20
TURN SIGNAL RELAY	6-20
BATTERY	6-21
SPECIFICATIONS	6-21
INITIAL CHARGING	6-21
SERVICING	6-22
RECHARGING OPERATION	6-23

CHARGING SYSTEM

DESCRIPTION

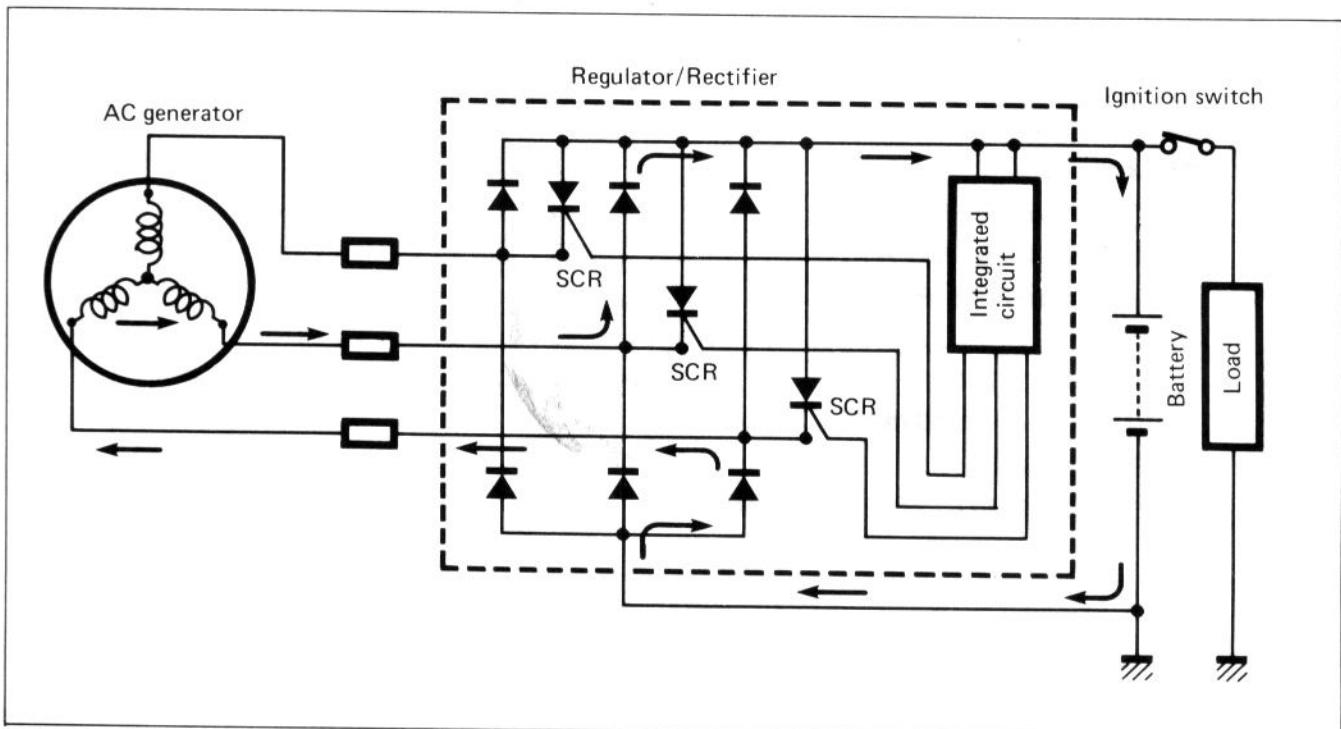
The circuit of the charging system is indicated in the figure, which is composed of an AC generator, regulator/rectifier unit and battery.

The AC current generated from the AC generator is rectified by the rectifier and is turned into DC current, then it charges the battery.



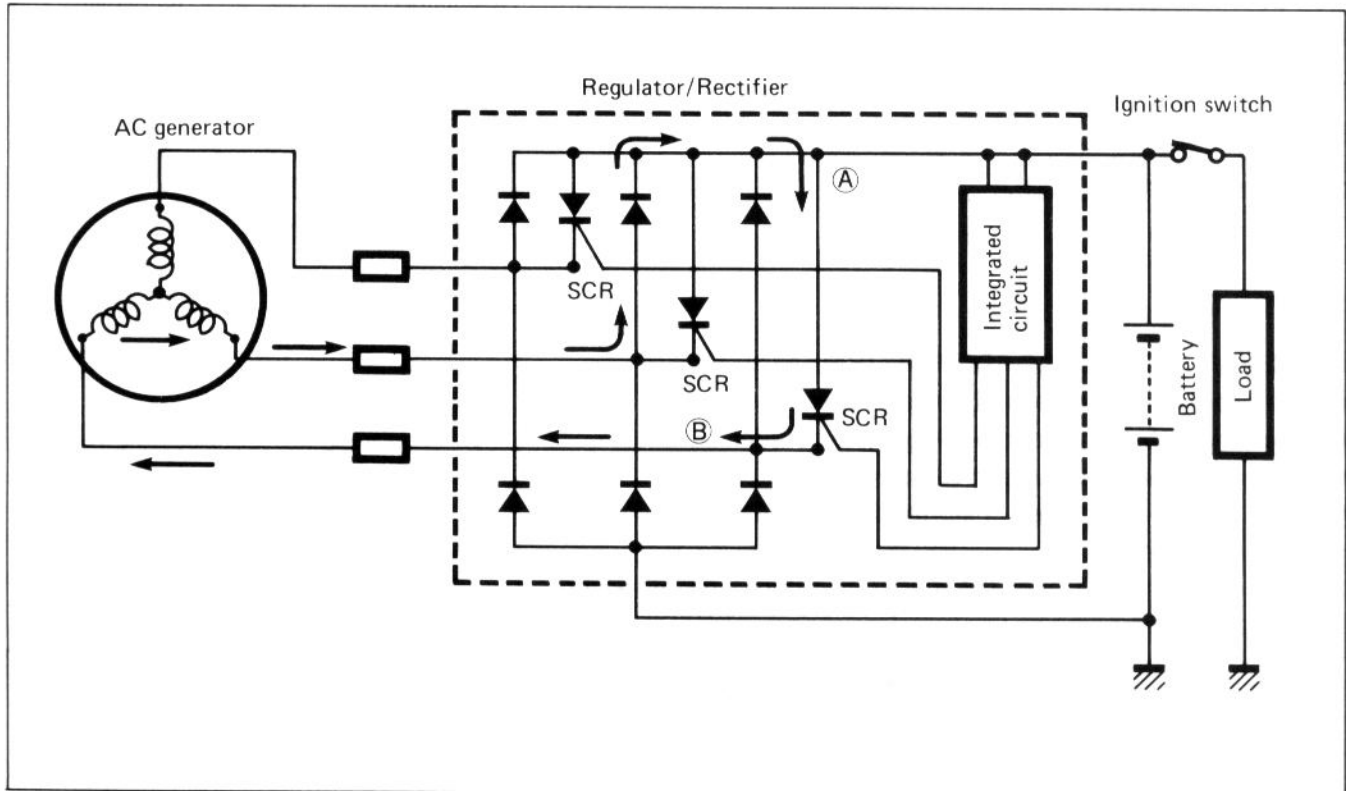
FUNCTION OF REGULATOR

While the engine r/min is low and the generated voltage of the AC generator is lower than the adjusted voltage of regulator, the regulator does not function. However, the generated current charges the battery directly at this time.



When the engine r/min becomes higher, the generated voltage of the AC generator also becomes higher and the voltage between the battery terminals becomes high accordingly. When it reaches the adjusted voltage of the I.C. (Integrated Circuit) and it is turned "ON", a signal will be sent to the SCR (Thyristor) gate probe and the SCR will be turned "ON".

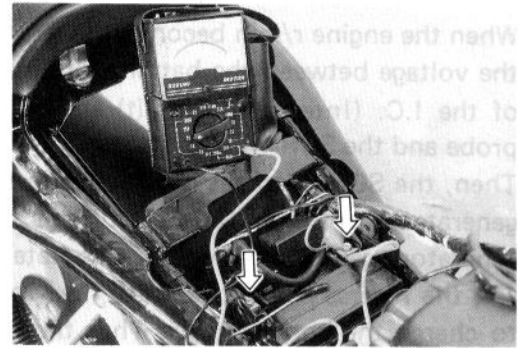
Then, the SCR becomes conductive in the direction from point (A) to point (B). At this time, the current generated from the AC generator gets through the SCR without charging the battery and returns to AC generator again. At the end of this state, since the AC current generated from AC generator flows to point (B), the reverse current tends to flow to SCR. Then, the circuit of SCR turns to the OFF mode and begins to charge the battery again. Thus these repetitions maintain charging voltage and current to the battery constant and protect it from overcharging.



INSPECTION

CHARGING OUTPUT CHECK

- Remove the seat.
- Start the engine and keep it running at 5 000 r/min with lighting switch turned ON and dimmer switch turned HI position.
- Using the pocket tester, measure the DC voltage between the battery terminals, ⊕ and ⊖.
If the tester reads under 13.5V or over 15.5V, check the AC generator no-load performance and regulator/rectifier.

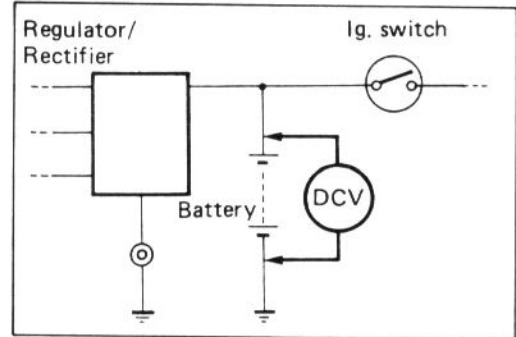


NOTE:

When making this test, be sure that the battery is fully-charged condition.

STD charging output : 13.5 – 15.5V (DC) at 5 000 r/min

09900-25002 : Pocket tester

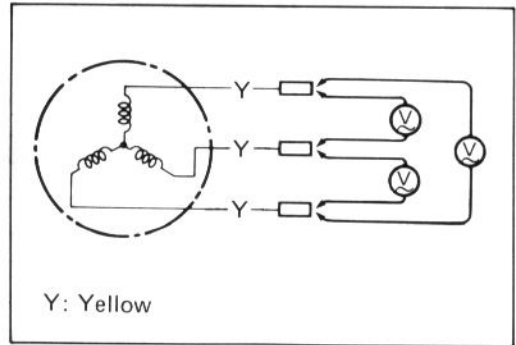


AC GENERATOR NO-LOAD PERFORMANCE

- Remove the seat and left air cleaner side cover.
- Disconnect the AC generator lead wire coupler.
- Start the engine and keep it running at 5 000 r/min.
- Using the pocket tester, measure the AC voltage between the three lead wires.
If the tester reads under the specified voltage, the AC generator is faulty.

STD no-load performance: More than 70V (AC) at 5000 r/min (When engine cold.)

09900-25002 : Pocket tester



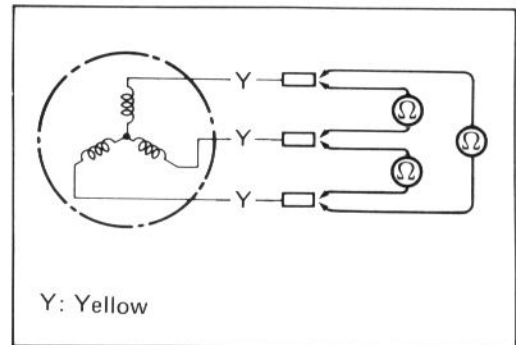
AC GENERATOR CONTINUITY CHECK

- Using the pocket tester, check the continuity between the three lead wires.
Check that there is no continuity between the lead wires and ground.

09900-25002 : Pocket tester

NOTE:

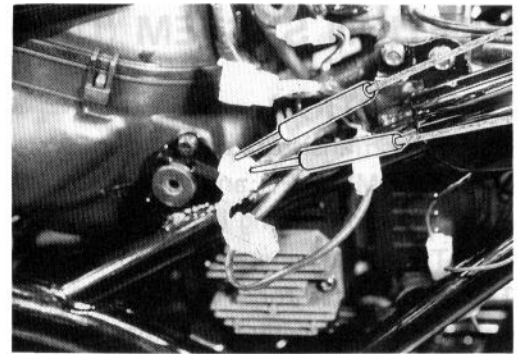
When making above test, it is not necessary to remove the AC generator.



REGULATOR/RECTIFIER

- Remove the seat and left air cleaner side cover.
- Disconnect the AC generator lead wire coupler.
- Using the pocket tester (x 1 k Ω range), measure the resistance between the lead wires in the following table.
If the resistance checked is incorrect, replace the regulator/rectifier.

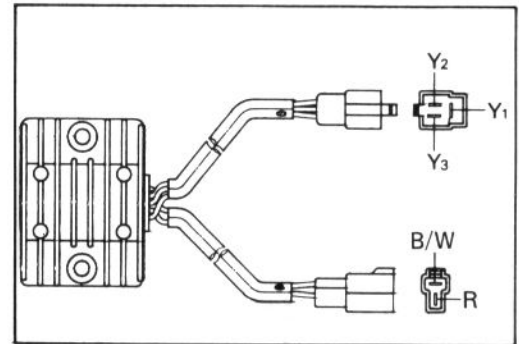
09900-25002 : Pocket tester

Unit: Approx. k Ω

⊖ Probe of tester to:	⊕ Probe of tester to:				
	Y ₁	Y ₂	Y ₃	R	B/W
Y ₁		∞	∞	3.5	∞
Y ₂	∞		∞	3.5	∞
Y ₃	∞	∞		3.5	∞
R	∞	∞	∞		∞
B/W	3.5	3.5	3.5	6	

Y: Yellow, R: Red, B/W: Black with White tracer, ∞ : Infinity**NOTE:**

As transistors, capacitors, Zener diodes, etc. are used inside this regulator/rectifier, the resistance values will differ when an ohmmeter other than the SUZUKI pocket tester is used.



IGNITION SYSTEM (DIGITAL IGNITOR)

DESCRIPTION

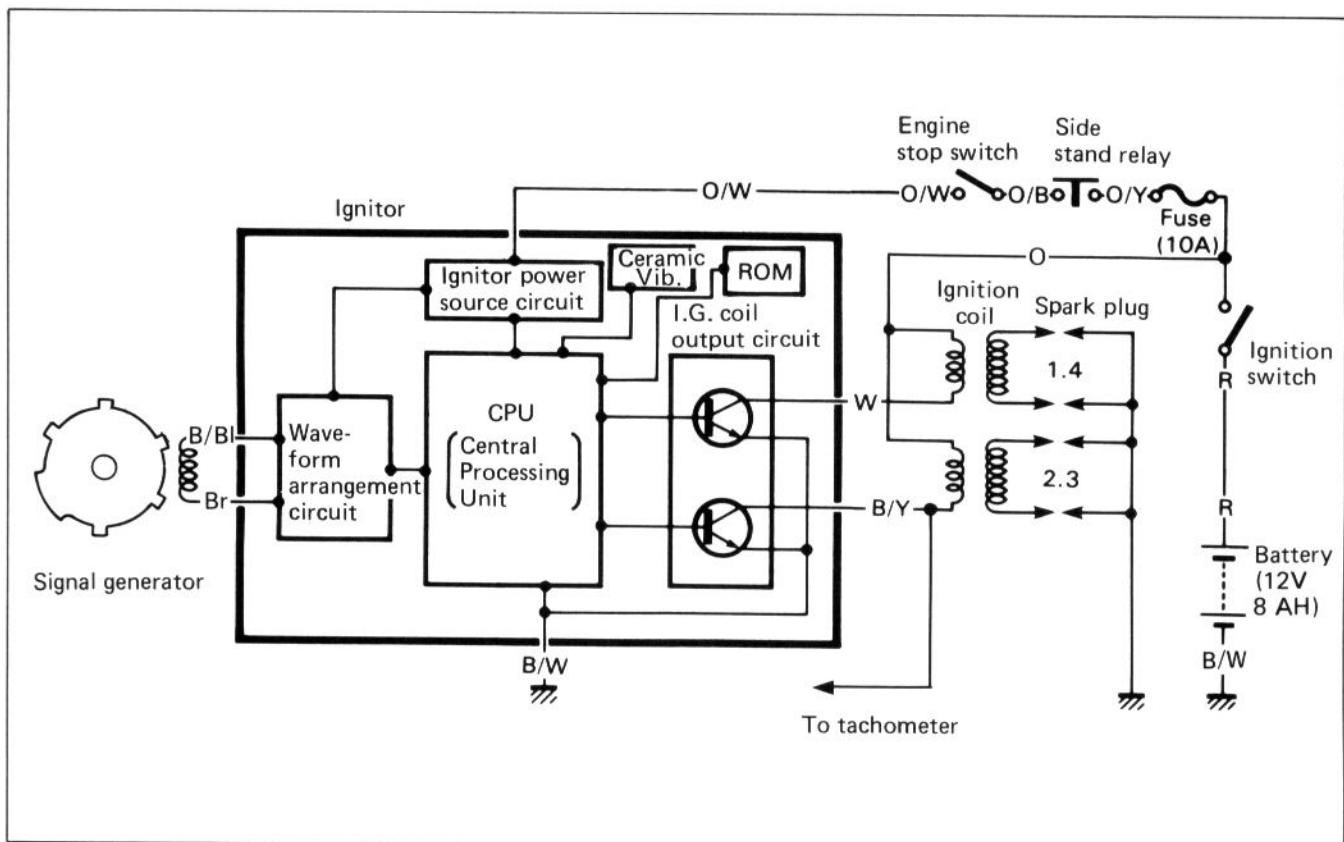
The fully transistorized ignition system consists of a signal generator, ignitor unit (including 8-BIT MICROCOMPUTER and CERAMIC 4MHZ VIBRATOR), ignition coils and spark plugs. The characteristic of the ignition timing is programmed and stored in the "ROM" (READ ONLY MEMORY) of the ignitor unit. The signal generator comprises the rotor tips and pickup coil.

The signal generator is mounted at the starter clutch. The induced signal in the signal generator is sent to wave-form arrangement circuit, and CPU receives this signal and calculates the best ignition timing from the signal of ceramic vibrator and data stored in the ROM. The CPU outputs signal to the transistor of the I.G. coil output circuit which is connected to the primary windings of the ignition coil which is turned OFF and ON accordingly, thus it induces the secondary current on the ignition coil secondary windings and produce the spark between spark plug gaps.

Ignition cut-off circuit is incorporated in the ignitor unit to prevent over-running engine. If engine r/min. reaches 13500 r/min., this circuit cuts off the ignition primary current for all spark plugs.

CAUTION:

Engine can run over 13500 r/min. without load, even if the ignition cut-off circuit is effective, and it may cause engine damage. Do not run the engine without load over 13500 r/min. at anytime.



INSPECTION

IGNITION COIL (Checking with Electro Tester)

- Remove the seat and both sides of the air cleaner side covers.
- Remove the fuel tank.
- Remove the ignition coils, left and right.

NOTE:

Make sure that the three-needle sparking distance of electro tester is set at 8 mm (0.3 in).

- With the tester and jumper wire, test the ignition coil for sparking performance in accordance with the following two steps.

STEP ①: Connect the jumper wire to the spark plug cap and ignition coil ground.

STEP ②: Switch over the jumper wire to the other plug cap and ground.

If no sparking or orange color sparking occurs in the above conditions, it may be caused by defective coil.

09900-28106: Electro tester

Spark performance: Over 8 mm (0.3 in)

IGNITION COIL (Checking with Pocket Tester)

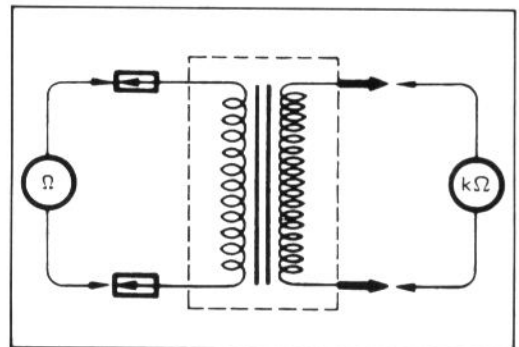
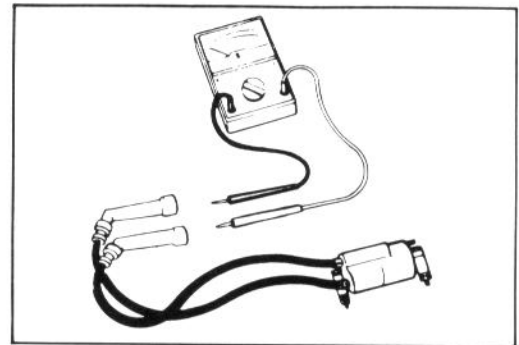
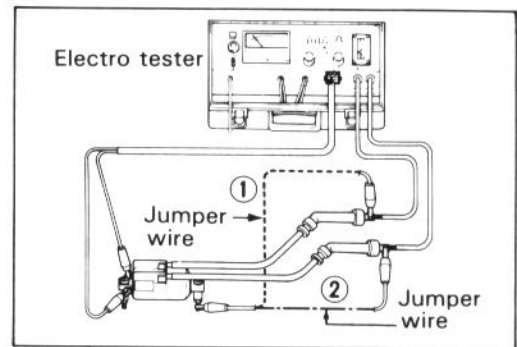
- A SUZUKI pocket tester or an ohm meter may be used, instead of the electro tester. In either case, the ignition coil is to be checked for continuity in both primary and secondary windings. Exact ohmic readings are not necessary, but, if the windings are in sound condition, their continuity will be noted with these approximate ohmic values.

09900-25002: Pocket tester

Ignition coil resistance

Primary : \oplus tap – \ominus tap 2.5 – 3.8 Ω
Tester range: (x 1 Ω)

Secondary : Plug cap – Plug cap 30 – 50 k Ω
Tester range: (x 1 k Ω)

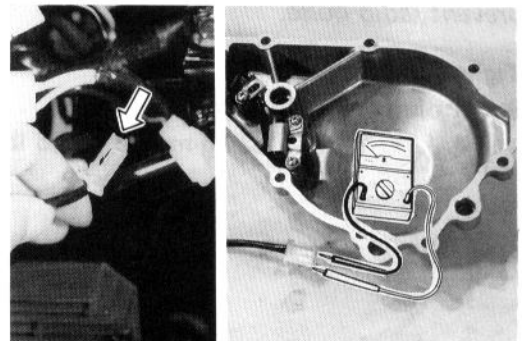


SIGNAL GENERATOR (Checking with Pocket Tester)

- Remove the seat and left air cleaner side cover.
- Disconnect the signal generator lead wire coupler.
- Measure the resistance between lead wires. If the resistance is infinity or less than the specifications, the signal generator must be replaced.

09900-25002: Pocket tester

Signal coil resistance : 80 – 120 Ω
(Brown – Black with Blue tracer)
Tester range : (x 10 Ω)



NOTE:

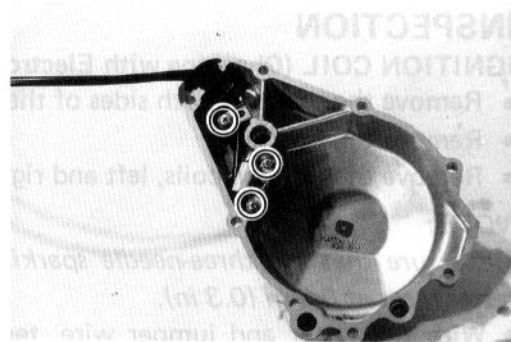
When replacing the signal generator coil, apply a small quantity of **THREAD LOCK SUPER "1322"/"1333B"** to its mounting screws and lead wire guide screws.

(For U.S.A. model)

99000-32020: THREAD LOCK SUPER "1333B"

(For the other models)

99000-32110: THREAD LOCK SUPER "1322"

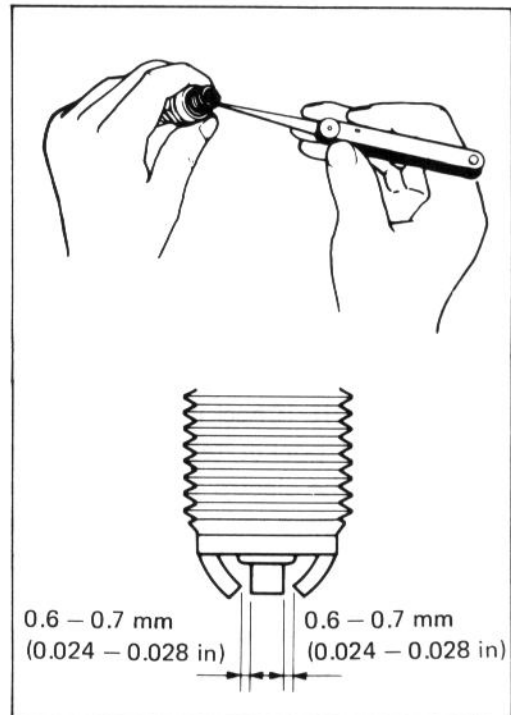


SPARK PLUG

- Clean the plug with a wire brush and pin. Use the pin to remove carbon, taking care not to damage the porcelain.

- Check the gap with a thickness gauge.

Spark plug gap: **0.6 – 0.7 mm (0.024 – 0.028 in)**



Recommended spark plug

- ND: U24ETR Standard
- ND: U22ETR Hot type
- ND: U27ETR Cold type
- NGK: CR8EK Standard
- NGK: CR7EK Hot type
- NGK: CR9EK Cold type

NOTE:

"R" type spark plug is installed for some specifications. "R" type spark plug has a resistor located at the center electrode to prevent radio noise.

Tightening torque

Spark plug: **10 – 12 N·m**
(1.0 – 1.2 kg·m, 7.0 – 8.5 lb·ft)

IGNITOR UNIT (Checking with Digital Ignitor Checker)

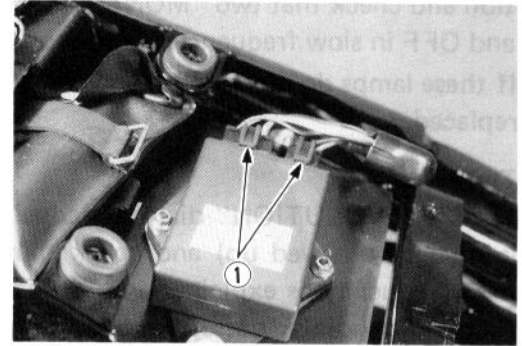
This section explains the checking procedure for the ignitor unit using Digital Ignitor Checker (special tool). With this checker, the ignitor unit can be checked either on the machine or off the machine. The following explains the checking procedure on the machine.

09931-94430: Digital ignitor checker

09931-94460: Adaptor

WIRING PROCEDURE:

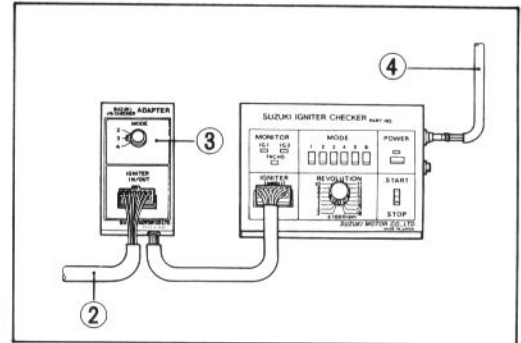
- Remove the seats, front and rear.
- Disconnect two ignitor lead wire couplers ① at the ignitor unit.



- Prepare the ignitor checker lead wire "MODE 2" ② and adaptor ③ which comes supplied with the ignitor checker and connect their ends to the ignitor unit and checker.
- Connect the power source leads ④ to the battery.

CAUTION:

- * Be sure that the **BLACK** lead is connected to the battery \ominus terminal and **RED** lead to the \oplus terminal.
- * Before connecting the power source leads, make sure that both "POWER" button and "START" switch are in "off" position (POWER button not depressed)

**NOTE:**

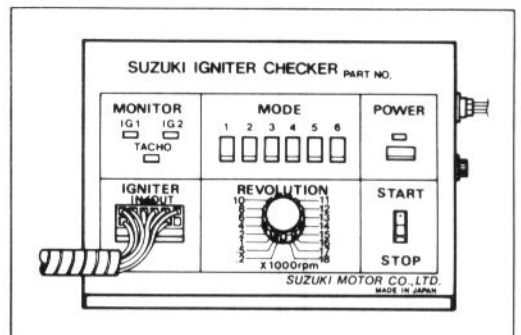
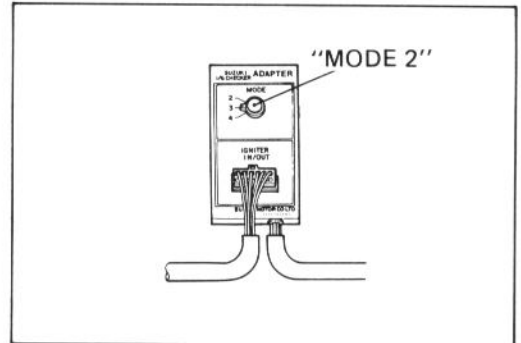
Be sure that the battery used is in fully-charged condition.

CHECK PROCEDURE:

With all the lead wires properly connected, check the ignitor unit in the following four steps.

First Step:

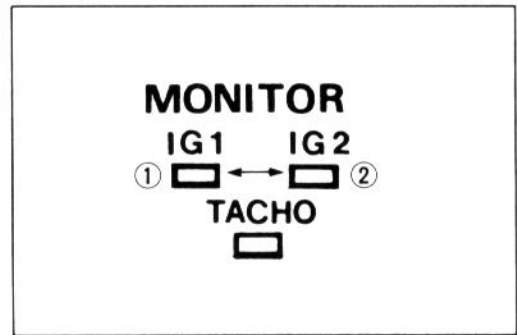
Set "MODE" switch on the adaptor to "2" position and depress "MODE 2" button then "POWER" button. This time, "POWER" lamp should come on, if not, battery is undercharged.



Second Step:

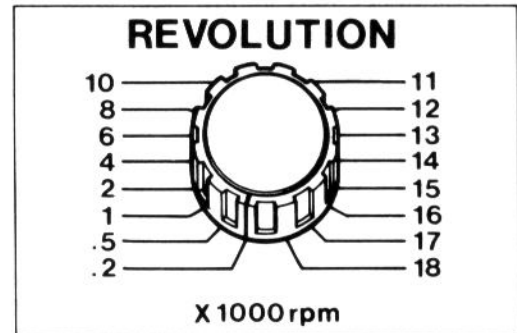
Set "REVOLUTION" dial pointer to "4" position in which the checker produces the ignition primary current pulses simulating 4000 r/min of engine revolution when "START" switch is turned on. With "START" switch is turned to ON position, check that two "MONITOR" lamps ① and ② turn ON. Then, turn back "REVOLUTION" dial pointer to ".2" position and check that two "MONITOR" lamps ① and ② turn ON and OFF in slow frequency in order of ① – ② as illustrated.

If these lamps do not turn on and off, the ignitor unit should be replaced.



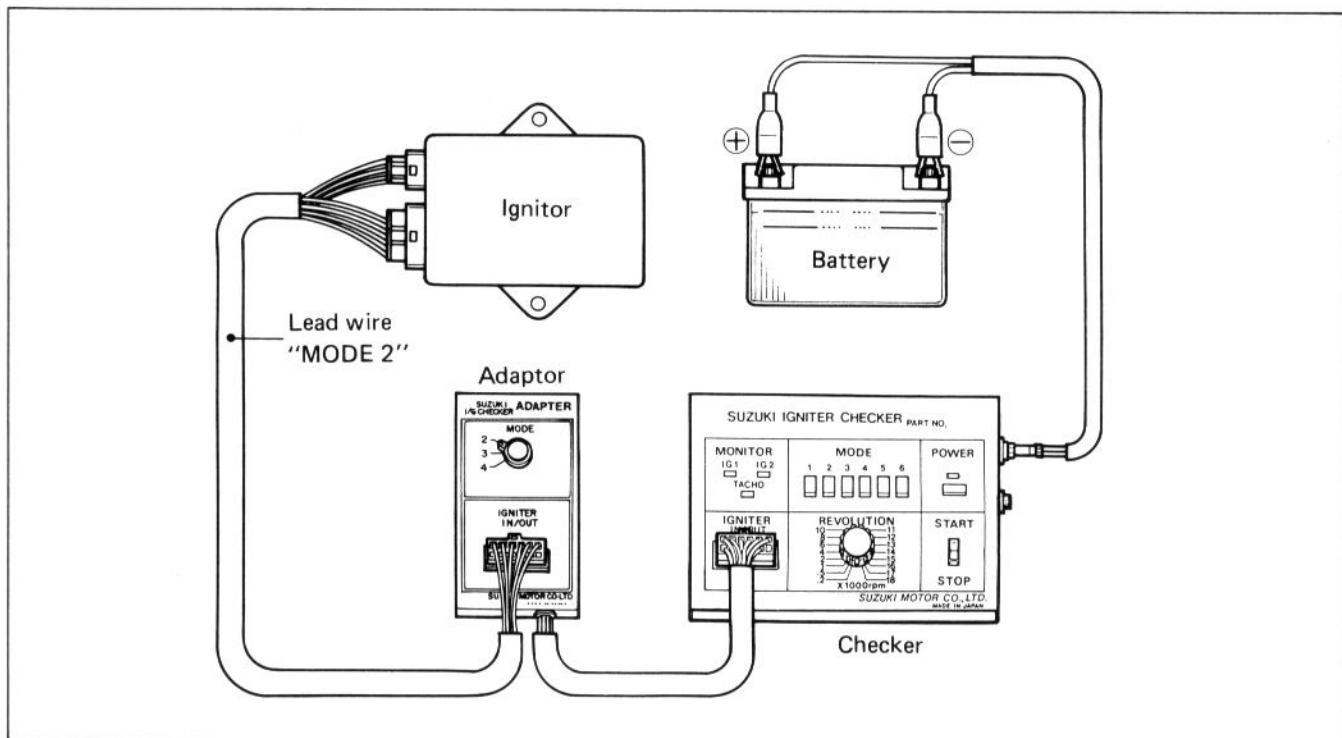
Third Step:

Turn "REVOLUTION" dial up gradually (assuming the engine is gradually revved up) and check that the MONITOR lamps flash frequency as explained in the second step above increases. As the dial pointer passes beyond the graduation "4" (4000 r/min), the two lamps should shown continuously lighted. When REVOLUTION dial pointer reaches between "13" and "14" (13000 – 14000 r/min), MONITOR ① lamp should show go off. This is because the ignition "cut-off" provided in the ignition system functions at 13500 ± 50 r/min. If the lamp go off at the graduation below "13", the engine can not perform properly and therefore the ignitor unit must be replaced.



Fourth Step:

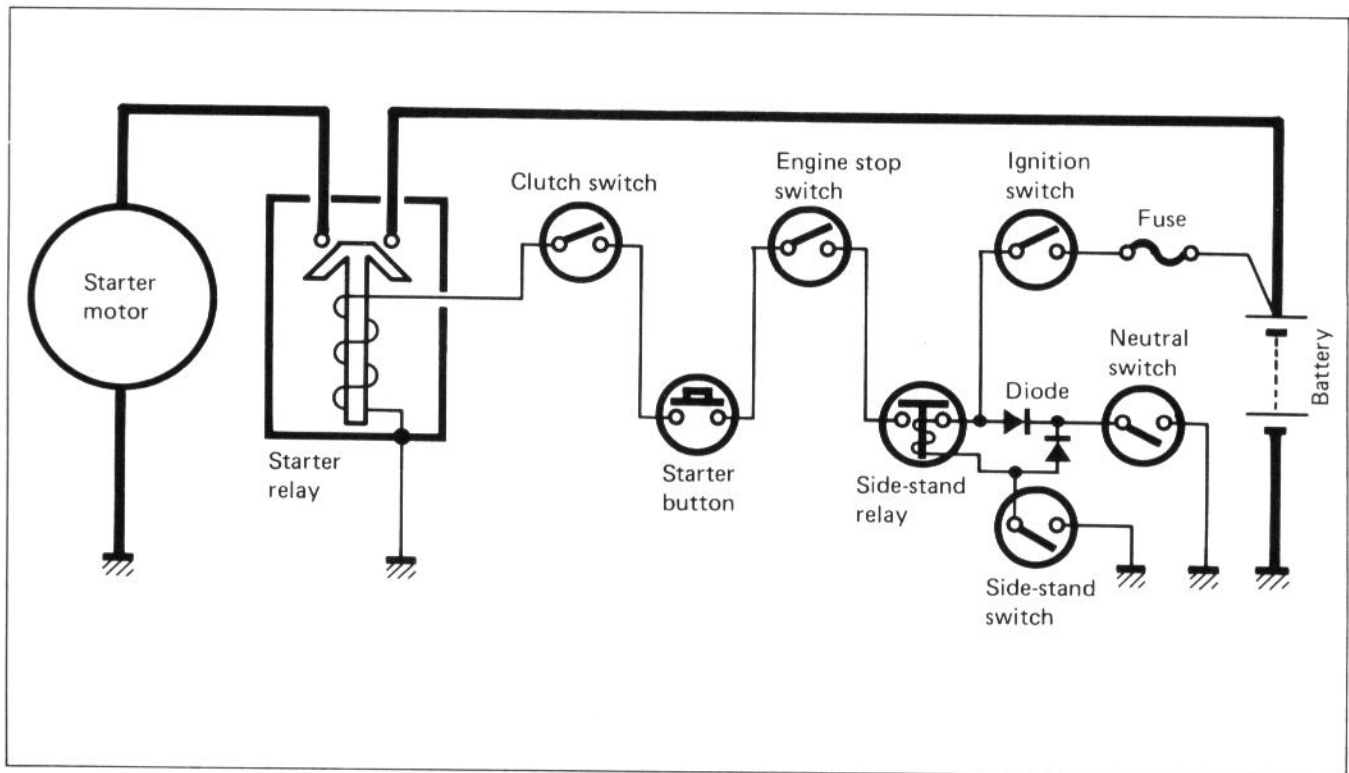
Turn "START" switch to STOP position. If the "IG1" or "IG2", or both lamps remain light more than 5 seconds, the ignitor unit must be replaced.



STARTER SYSTEM

DESCRIPTION

The starter system is shown in the diagram below: namely, the starter motor, starter relay, side stand relay, clutch switch, starter button, engine stop switch, side stand switch, IG switch and battery. Depressing the starter button (on the right handlebar switch box) energizes the relay, causing the contact points to close which connects the starter motor to the battery. The motor draws about 80 amperes to start the engine.

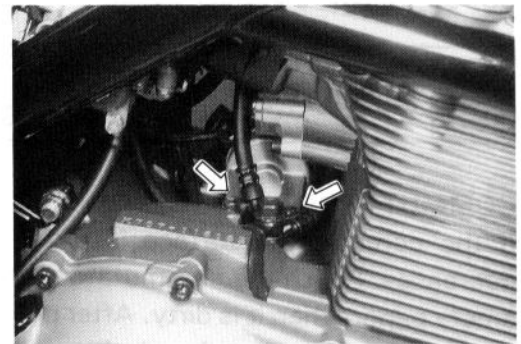


REMOVAL AND DISASSEMBLY

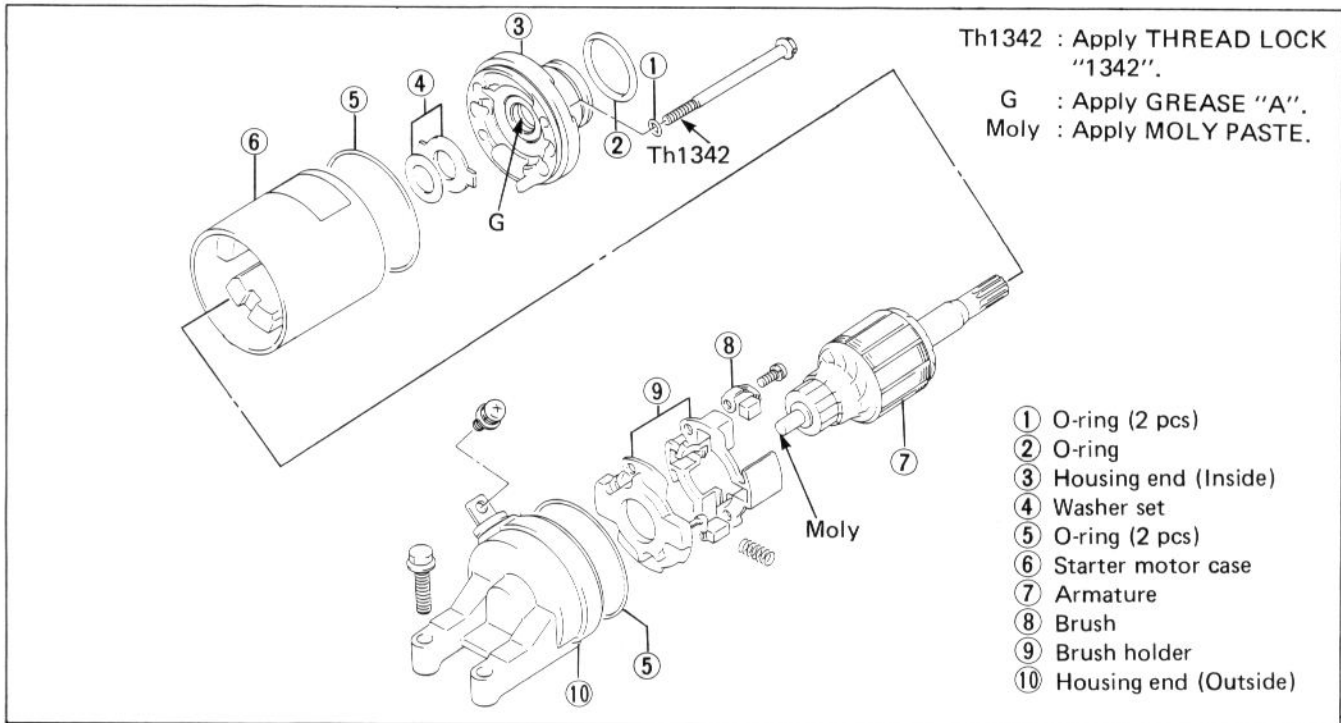
- Disconnect the starter motor lead wire and remove the starter motor. (Refer to pages 3-7 and 3-12.)

NOTE:

If it is difficult to remove the starter motor, loosen the oil hose union bolt on the upper crankcase to provide additional clearance.



- Disassemble the starter motor as shown in the illustration.



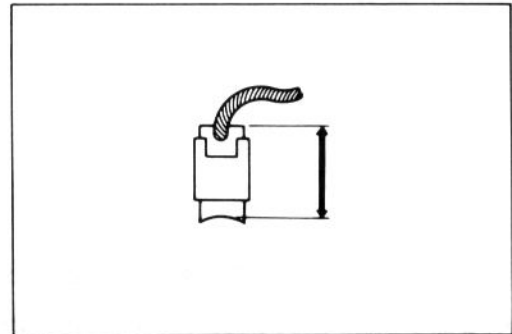
INSPECTION

CARBON BRUSH

When the brushes are worn, the motor will be unable to produce sufficient torque, and the engine will be difficult to turn over. To prevent this, periodically, measure the length of the brushes with a vernier calipers, replacing them when they are too short or chipping.

09900-20102 : Vernier calipers (200 mm)

Brush length	Service Limit
	3.5 mm (0.14 in)



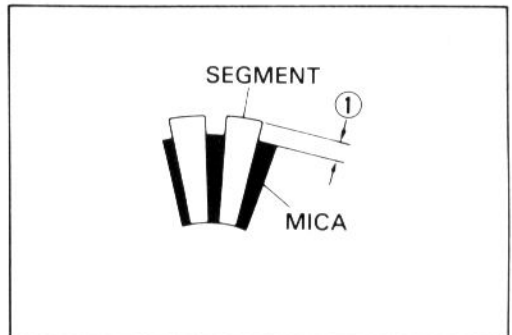
COMMUTATOR

If the commutator surface is dirty, starting performance decreases. Polish the commutator with # 400 or similar fine emery paper when it is dirty. After polishing it, wipe the commutator with a clean dry cloth.

Measure the commutator under cut ① with a vernier calipers.

09900-20102 : Vernier calipers (200 mm)

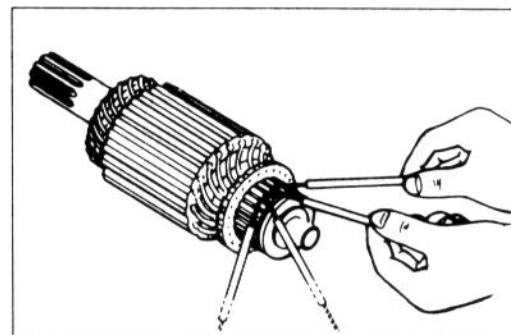
Commutator under-cut	Service Limit
	0.5 mm (0.02 in)



ARMATURE COIL

Using a pocket tester, check the coil for open and ground by placing probe pins on each commutator segment and rotor core (to test for ground) and on any two segments at various places (to test for open), with the brushes lifted off the commutator surface.

If the coil is found to be open-circuited or grounded replace the armature. Continuous use of a defective armature will cause the starter motor to suddenly fail.



09900-25002 : Pocket tester

Tester knob indication : $\times 1\Omega$ range

OIL SEAL

Check the seal lip for damage or oil leakage. If any damage is found, replace it.

REASSEMBLY

Reassemble the starter motor in the reverse order of disassembly. Pay attention to the following points:

O-RING**CAUTION:**

Replace the O-rings with new ones to prevent oil leakage and moisture.

HOUSING END (Inside)

- Apply grease to the lip of oil seal. (Refer to page 6-11.)

(For U.S.A. model)

99000-25030 : SUZUKI SUPER GREASE "A"

(For the other models)

99000-25010 : SUZUKI SUPER GREASE "A"

HOUSING END (Outside)

- Apply a small quantity of SUZUKI MOLY PASTE to the armature end. (Refer to page 7-11.)

99000-25140 : SUZUKI MOLY PASTE

- Apply a small quantity of THREAD LOCK "1342" to the starter motor housing bolts. (Refer to page 6-11.)

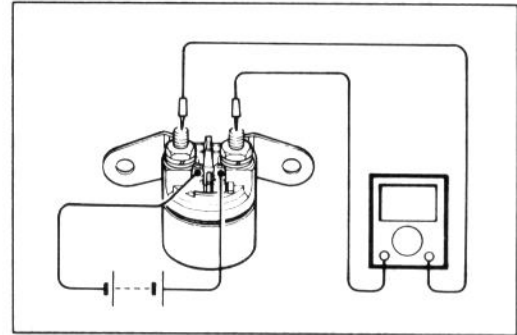
99000-32050 : THREAD LOCK "1342"

STARTER RELAY INSPECTION

- Disconnect the lead wire of starter motor at starter relay which is located battery holder of right side.
- Turn on the ignition switch, inspect the continuity between the terminals, positive and negative, when squeezing the clutch lever and pushing the starter button.
If the starter relay is in sound condition, continuity is found.

09900-25002 : Pocket tester

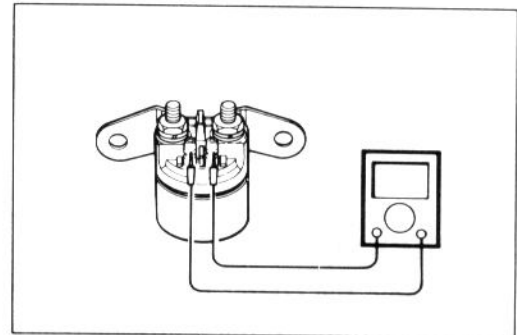
Tester knob indication : $\times 1\Omega$ range



- Disconnect the lead wires from the starter relay.
- Check the coil for "open", "ground" and ohmic resistance.
The coil is in good condition if the resistance is as follows.

09900-25002 : Pocket tester

Tester knob indication : $\times 1\Omega$ range

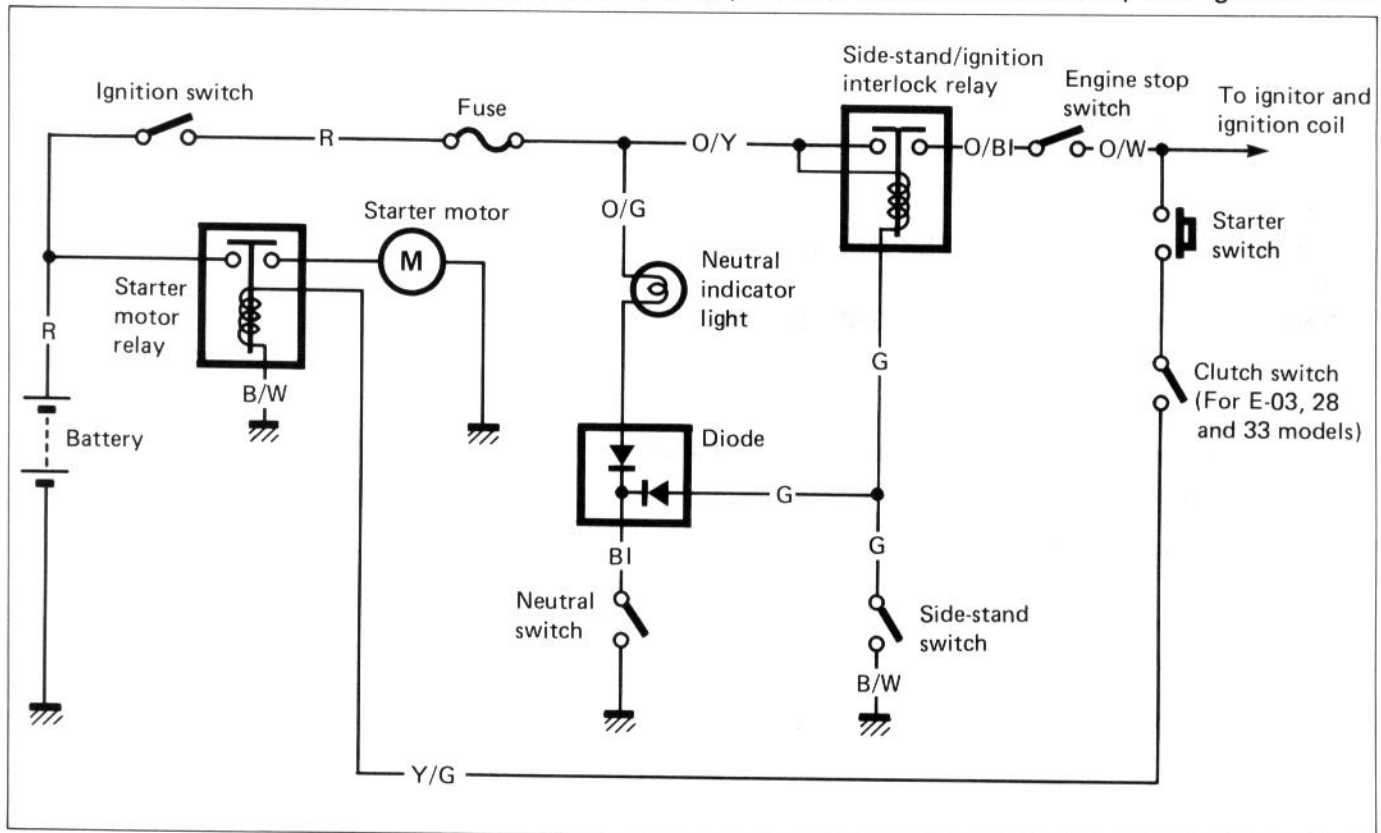


Starter relay resistance	Standard
	3 – 5Ω

SIDE-STAND/IGNITION INTERLOCK SYSTEM

DESCRIPTION

This side-stand/ignition interlock system is to prevent starting the motorcycle with the side-stand left down. The system is operated by an electric circuit provided between the battery and ignition coil.



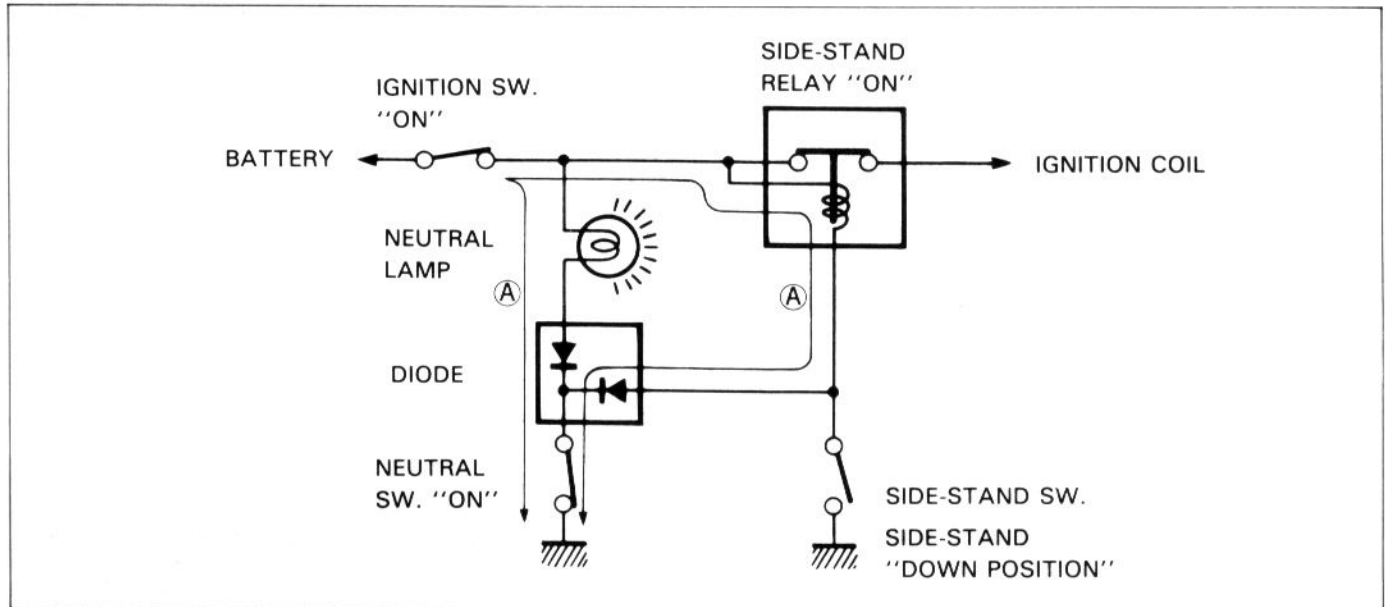
The circuit consists of relay, lamp, diode and switches and decides to live the ignition coil depending on the position of the TRANSMISSION and SIDE-STAND with the neutral and side-stand switches working mutually.

The ignition coil lives only in two situations as follows:

1. Transmission: "NEUTRAL (ON)" Side-stand: "DOWN (OFF)"

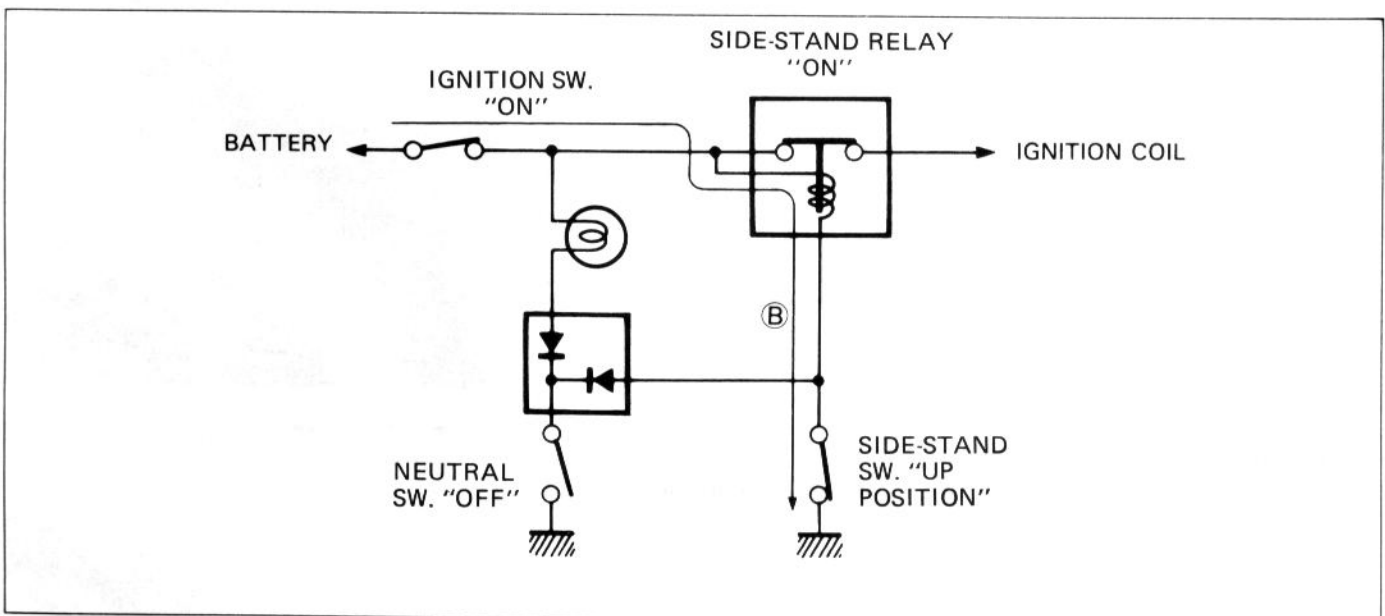
The current flow (A) turns "ON" the relay and the ignition coil lives even the side-stand is kept down.

This is for warming up the engine.



2. Side-stand: "UP (ON)"

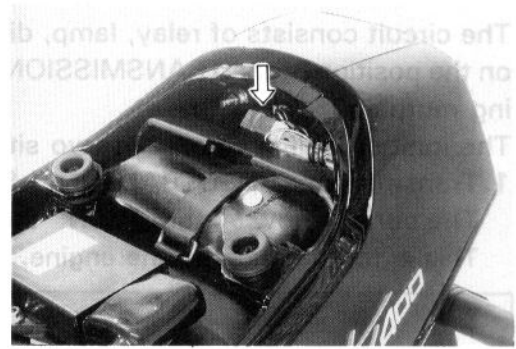
The current flow (B) turns "ON" the relay and the ignition coil lives. The engine can be easily started at any transmission position.



INSPECTION

If the interlock system does not operate properly, check each component. If any abnormality is found, replace the component with a new one.

09900-25002 : Pocket tester

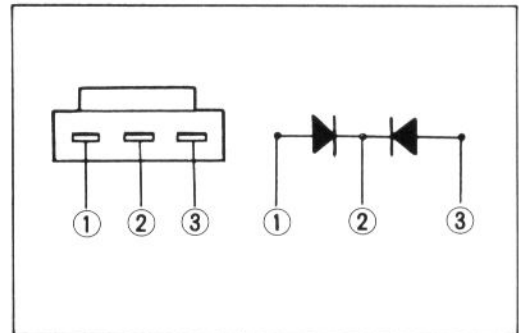


Diode

The diode is located behind the tool bag.

The diode can pass current only in one direction.

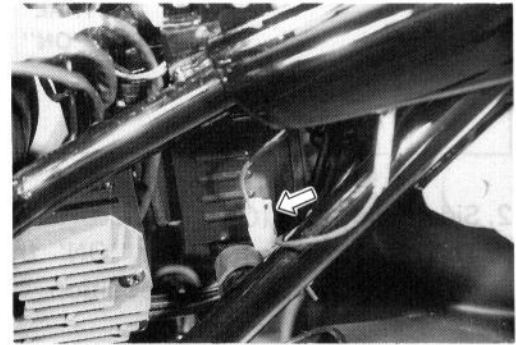
- Check the continuity between ① and ②. If one way continuity the diode is in good condition.
- Also check the continuity between ② and ③ as required.



Neutral switch

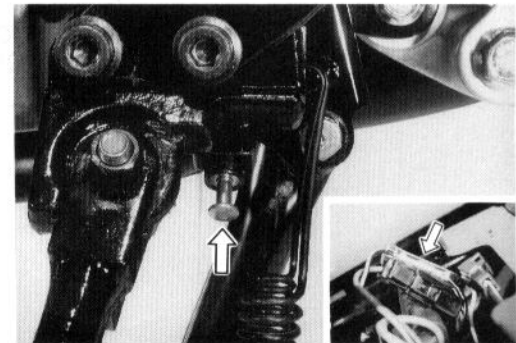
The neutral lead wire coupler is located behind the battery holder.

- Disconnect the neutral switch lead and check the continuity between BI and ground with the transmission in "NEUTRAL".



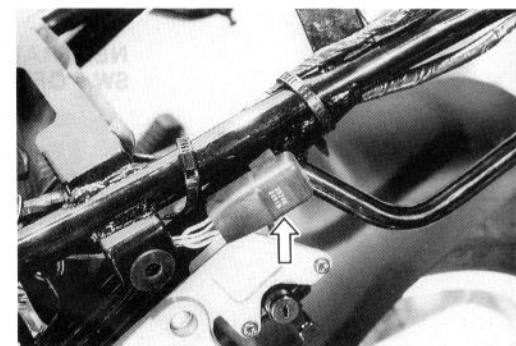
Side-stand switch

	G	B/W
ON (UP position)	○	○
OFF (Down position)		



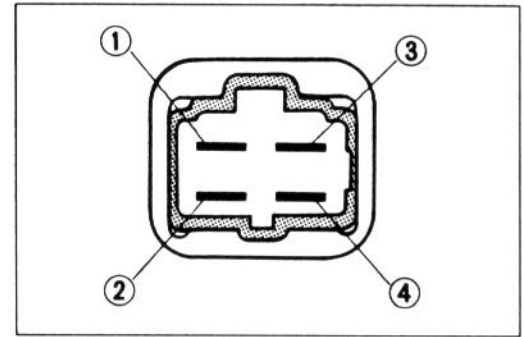
Side-stand/ignition interlock relay

The side-stand/ignition interlock relay is located on the left frame back side.



First, check the insulation between ① and ② terminals with pocket tester. Then apply 12 volts to ③ and ④ terminals, \oplus to ③ and \ominus to ④, and check the continuity between ① and ②.

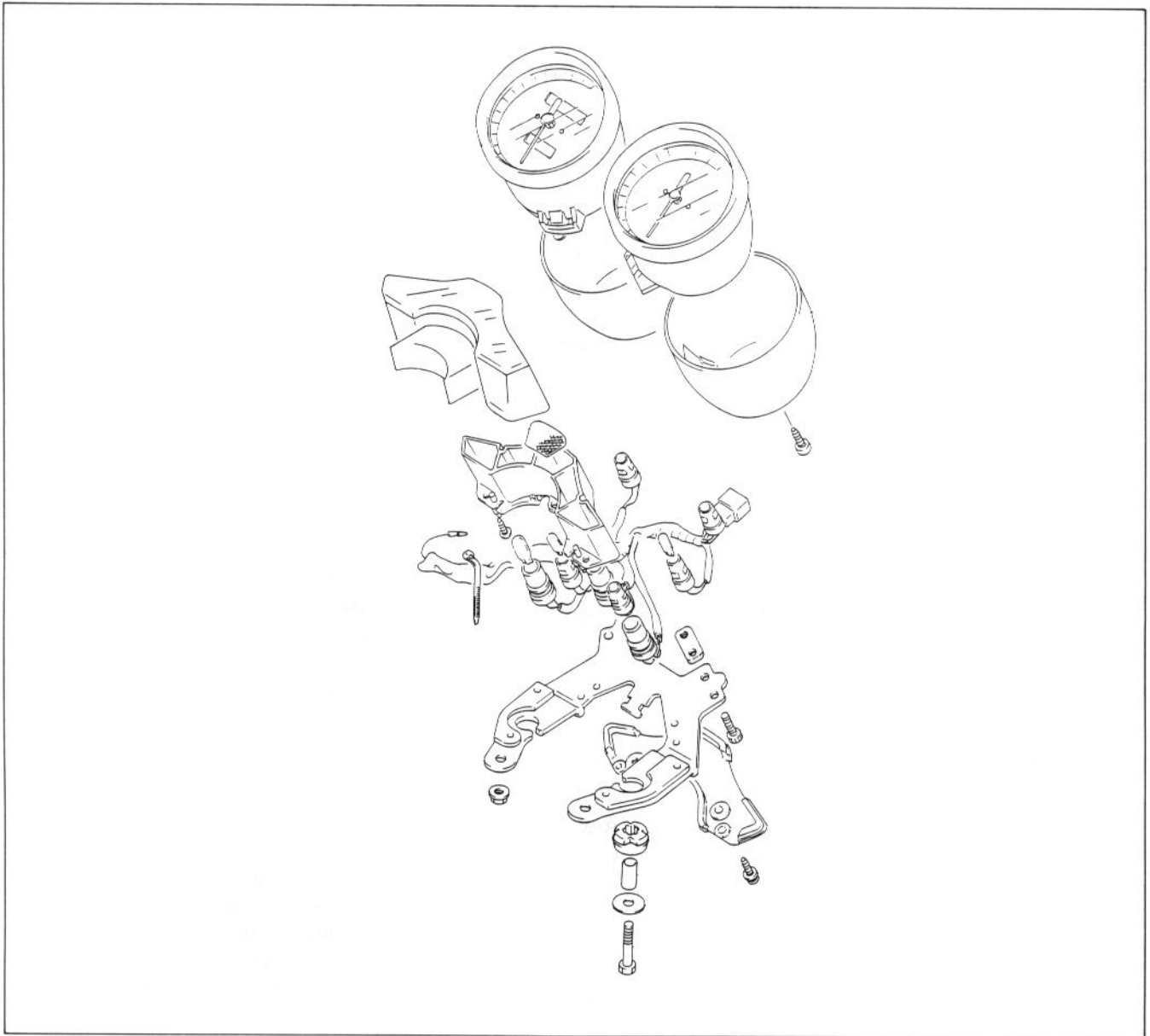
If there is no continuity, replace it with a new one.



COMBINATION METER

REMOVAL AND DISASSEMBLY

- Disassemble the combination meter as follows.



INSPECTION

Using the pocket tester, check the continuity between lead wires in the diagram as shown below.

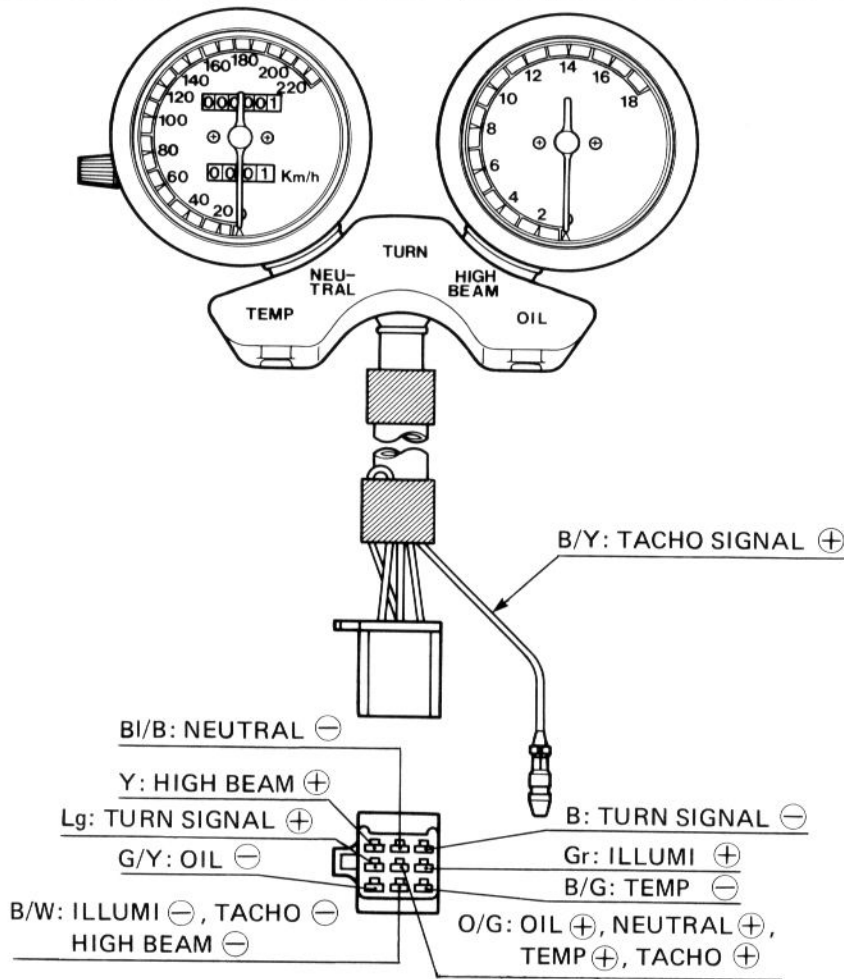
If the continuity measured is incorrect, replace the respective parts.

09900-25002 : Pocket tester

Tester knob indication : $\times 1\Omega$ range

NOTE:

When making this test, it is not necessary to remove the combination meter.

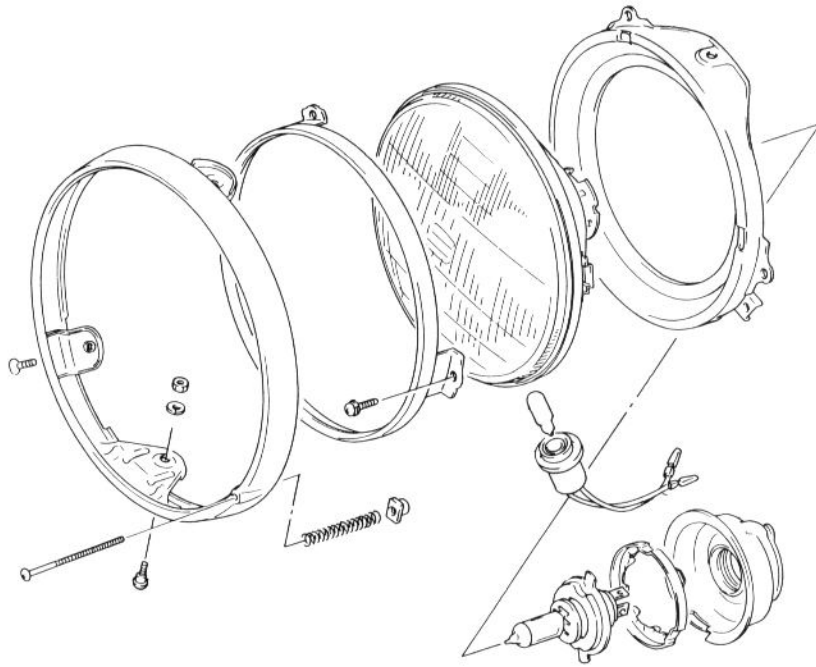


ITEM	⊕ Probe of tester to:	⊖ Probe of tester to:
TURN SIGNAL	Lg	B
ILLUMI	Gr	B/W
HIGH BEAM	Y	B/W
OIL	O/G	G/Y
NEUTRAL	O/G	BI/B
TEMP	O/G	B/G
TACHO	O/G and B/Y	B/W

- WIRE COLOR**
- B : Black
 - Lg : Light green
 - Gr : Gray
 - Y : Yellow
 - O/G : Orange with Green tracer
 - BI/B : Blue with Black tracer
 - B/W : Black with White tracer
 - G/Y : Green with Yellow tracer
 - B/G : Black with Green tracer
 - B/Y : Black with Yellow tracer

LAMPS

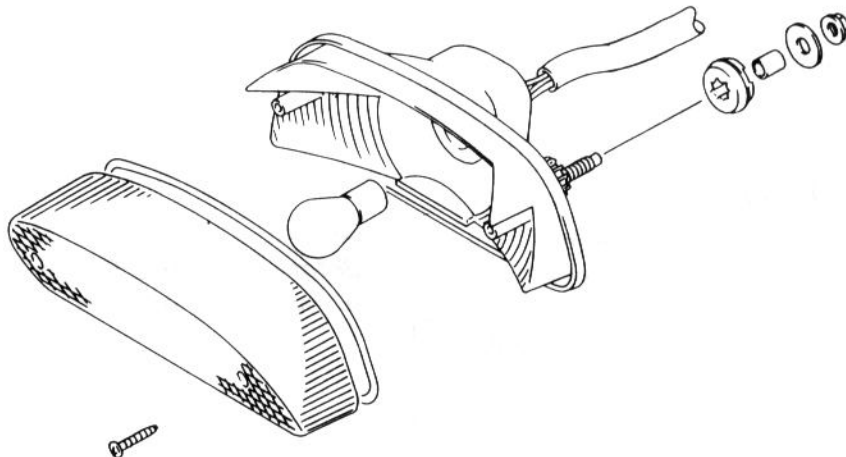
HEADLIGHT



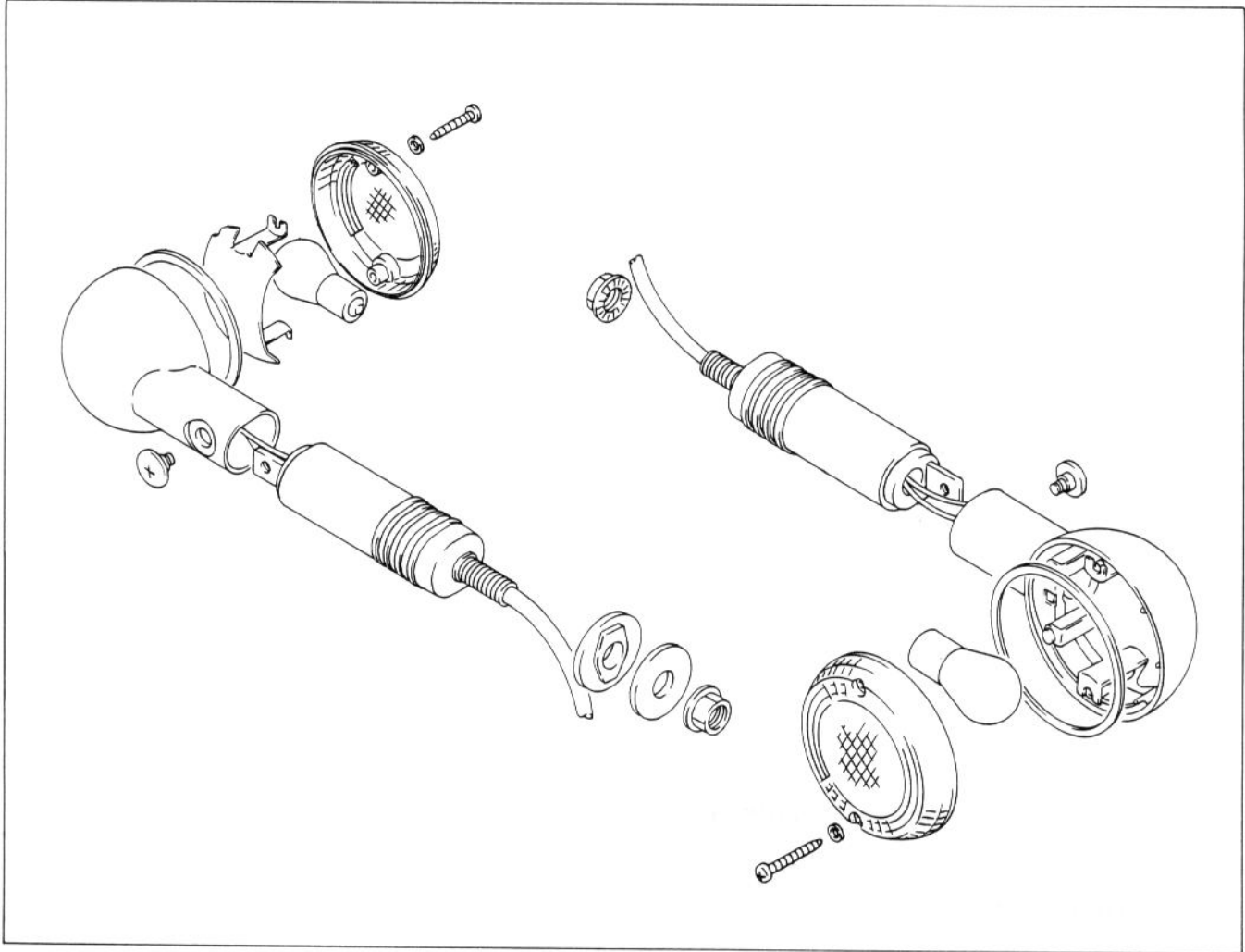
NOTE:

Adjust the headlight, both vertical and horizontal, after reassembling.

TAIL/BRAKE LIGHT



TURN SIGNAL LIGHT



SWITCHES

Inspect each switch for continuity with the pocket tester referring to the wiring diagram. If any abnormality is found, replace the respective switch assemblies with new ones. (Refer to the chapter 8 of wiring diagram.)

09900-25002 : Pocket tester

Tester knob indication : $\times 1\Omega$ range

OIL PRESSURE SWITCH

- Continuity, when engine is stopped.
- No continuity, when engine is running.

NOTE:

Before inspecting the oil pressure switch, check if the engine oil level is enough.

	B/G	Ground
ON	○ — ○	○ — ○
OFF		

RELAY

STARTER RELAY

The starter relay is located behind the battery. (Refer to page 6-13 for details.)

SIDE-STAND RELAY

The side-stand relay is located on the left frame back side. (Refer to page 6-13 for details.)

TURN SIGNAL RELAY

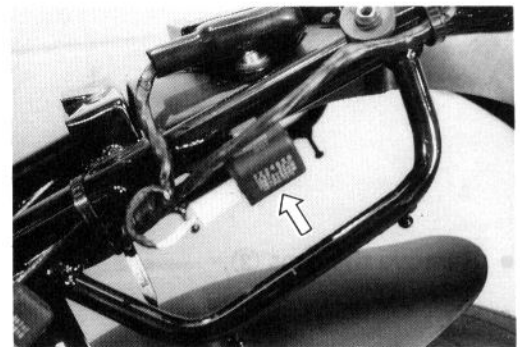
The turn signal relay is located on the left frame back side.

If the turn signal light does not light, inspect the bulb or repair the circuit connection.

If the bulb and circuit connection checked are correct, the turn signal relay may be faulty, replace it with a new one.

NOTE:

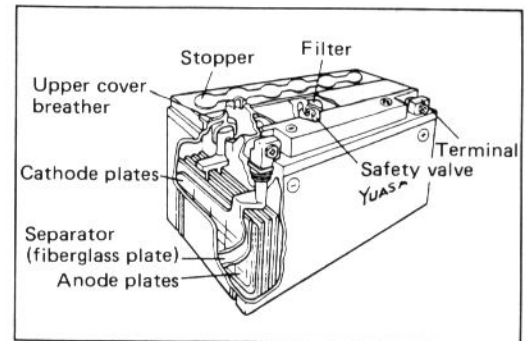
Be sure that the battery used is in fully-charged condition.



BATTERY

SPECIFICATIONS

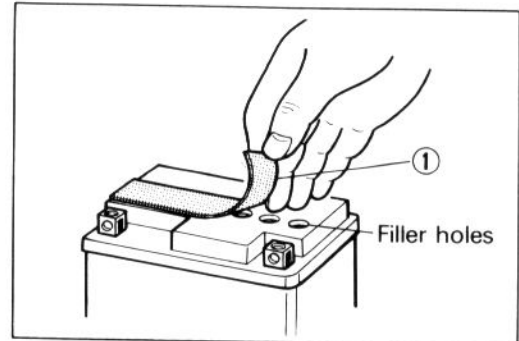
Type designation	YTX9-BS
Capacity	12V 28.8 kC (8 Ah)/10HR
Standard electrolyte S.G.	1.320 at 20°C (68°F)



INITIAL CHARGING

Filling electrolyte

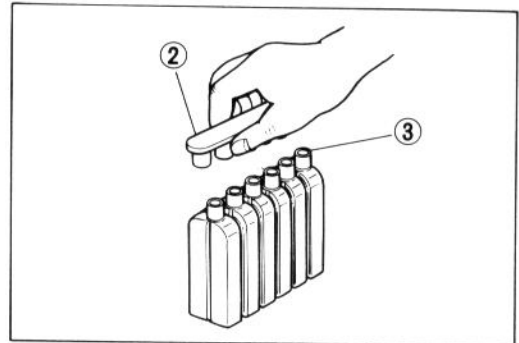
- Remove the aluminum tape ① sealing the battery electrolyte filler holes.



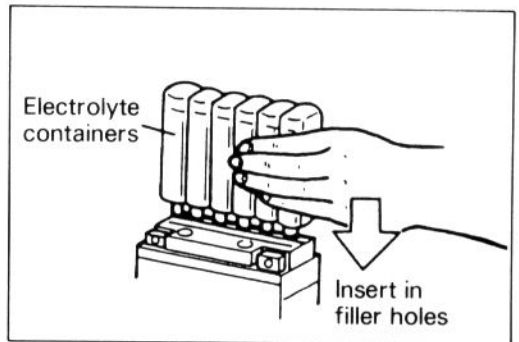
- Remove the caps ②.

NOTE:

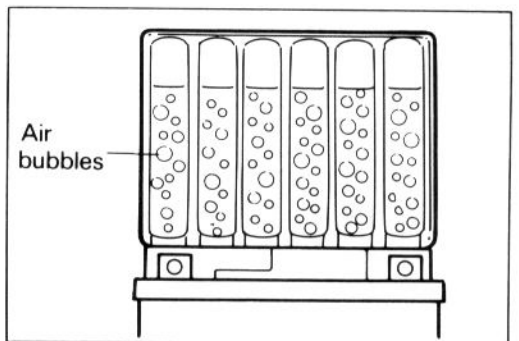
- * After filling the electrolyte completely, use the removed cap ② as the sealed caps of battery-filler holes.
- * Do not remove or pierce the sealed areas ③ of the electrolyte container.



- Insert the nozzles of the electrolyte container into the battery's electrolyte filler holes, holding the container firmly so that it does not fall. Take precaution not to allow any of the fluid to spill.



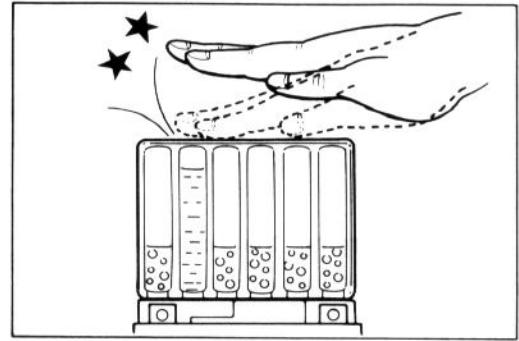
- Make sure air bubbles are coming up each electrolyte container, and leave in this position for about more than 20 minutes.



NOTE:

If no air bubbles are coming up from a filler port, tap the bottom of the two or three times.

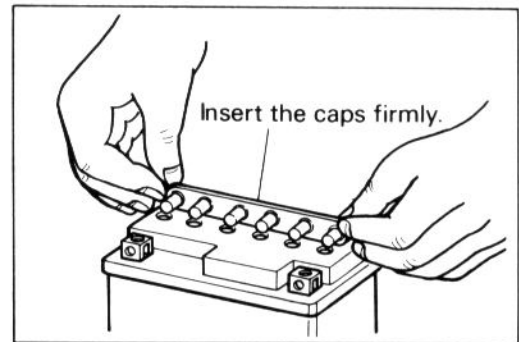
Never remove the container from the battery.



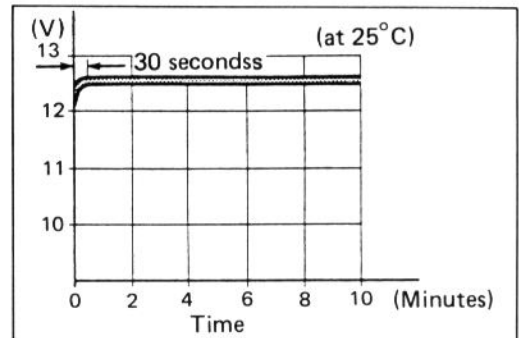
- After confirming that the electrolyte has entered the battery completely, remove the electrolyte containers from the battery. Wait for around 20 minutes.
- Insert the caps into the filler holes, pressing in firmly so that the top of the caps do not protrude above the upper surface of the battery's top cover.

CAUTION:

- * Never uses anything except the specified battery.
- * Once install the caps to the battery; do not remove the caps.



- Using SUZUKI pocket tester, measure the battery voltage. The tester should indicate more than 12.5 – 12.6 V (DC) as shown in the Fig. If the battery voltage is lower than the specification, charge the battery with a battery charger. (Refer to the recharging operation.)

**NOTE:**

Initial charging for a new battery is recommended if two years have elapsed since the date of manufacture.

SERVICING

Visually inspect the surface of the battery container. If any signs of cracking or electrolyte leakage from the sides of the battery have occurred, replace the battery with a new one. If the battery terminals are found to be coated with rust or an acidic white powdery substance, then this can be cleaned away with sandpaper.

RECHARGING OPERATION

- Using the pocket tester, check the battery voltage. If the voltage reading is less than the 12.0V (DC), recharge the battery with a battery charger.

CAUTION:

When recharging the battery, remove the battery from the motorcycle.

NOTE:

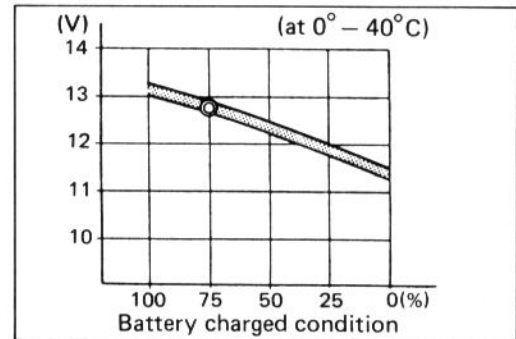
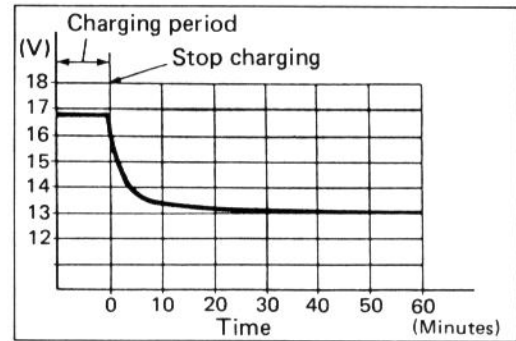
Do not remove the stoppers on the battery top while recharging.

Recharging time: 4A for one hour or 0.9A for 5 hours

CAUTION:

Be careful not to permit the charging current to exceed 4A at any time.

- After recharging, wait for more than 30 minutes and check the battery voltage with a pocket tester.
- If the battery voltage is less than the 12.5V, recharge the battery again.
- If battery voltage is still less than 12.5V, after recharging, replace the battery with a new one.
- When a battery is left for a long term without using, it is subject to discharge. When the motorcycle is not used for more than 1 month (especially during the winter season), recharge the battery once a month at least.

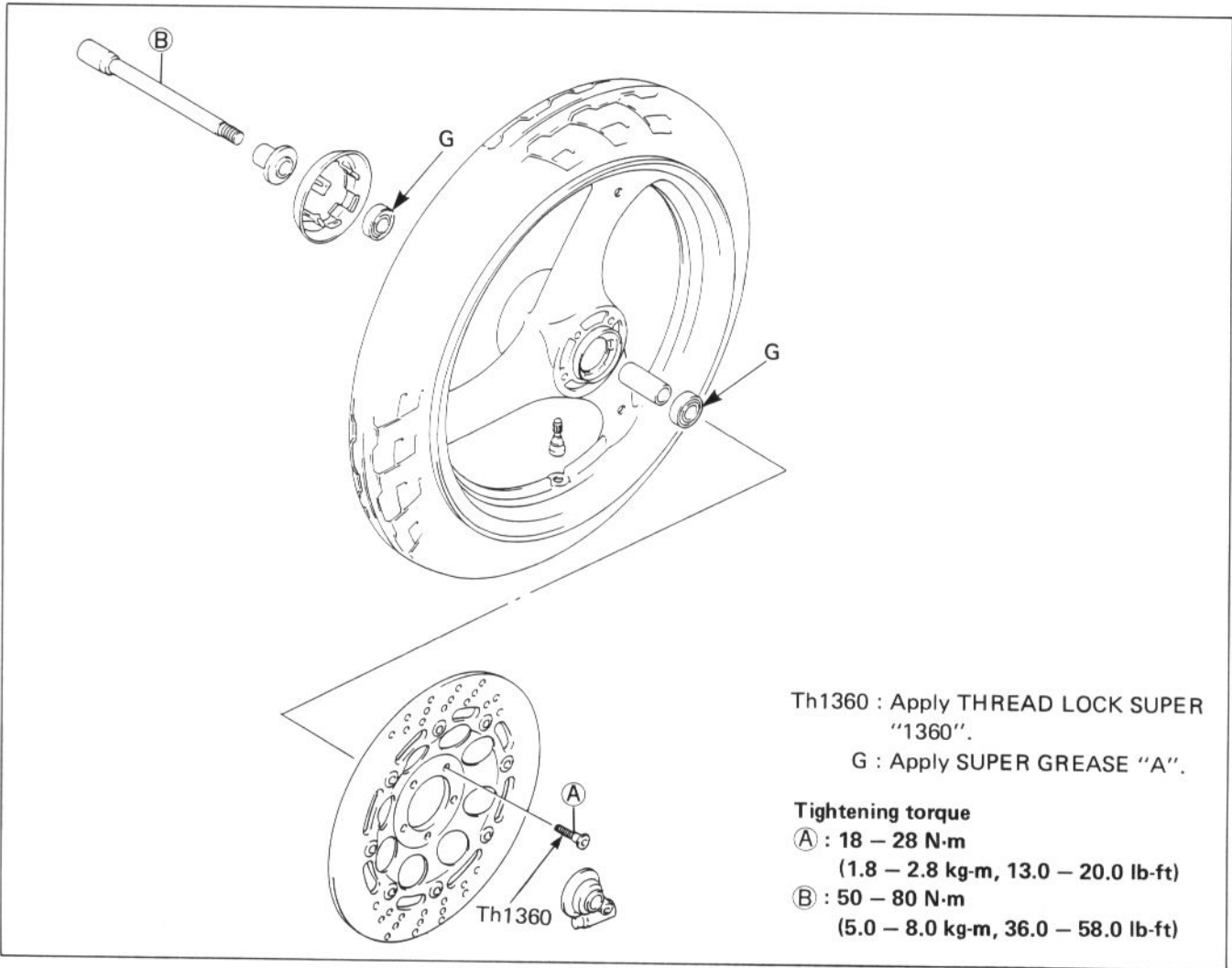


CHASSIS

CONTENTS

FRONT WHEEL	7- 1
REMOVAL	7- 1
INSPECTION AND DISASSEMBLY	7- 2
REASSEMBLY AND REMOUNTING	7- 3
FRONT BRAKE	7- 6
BRAKE PAD REPLACEMENT	7- 6
CALIPER REMOVAL AND DISASSEMBLY	7- 7
CALIPER AND DISC INSPECTION	7- 7
CALIPER REASSEMBLY AND REMOUNTING	7- 8
MASTER CYLINDER REMOVAL AND DISASSEMBLY	7- 8
MASTER CYLINDER INSPECTION	7-10
MASTER CYLINDER REASSEMBLY AND REMOUNTING	7-10
FRONT FORK	7-11
REMOVAL	7-11
DISASSEMBLY	7-12
INSPECTION	7-13
REASSEMBLY AND REMOUNTING	7-14
STEERING	7-16
REMOVAL	7-17
DISASSEMBLY	7-17
INSPECTION	7-18
REASSEMBLY AND REMOUNTING	7-18
STEERING TENSION ADJUSTMENT	7-19
IGNITION SWITCH	7-20
REAR BRAKE	7-21
BRAKE PAD REPLACEMENT	7-21
CALIPER REMOVAL AND DISASSEMBLY	7-22
CALIPER AND DISC INSPECTION	7-23
CALIPER REASSEMBLY AND REMOUNTING	7-23
MASTER CYLINDER REMOVAL AND DISASSEMBLY	7-24
MASTER CYLINDER INSPECTION	7-25
MASTER CYLINDER REASSEMBLY AND REMOUNTING	7-26
REAR WHEEL	7-27
REMOVAL	7-27
INSPECTION AND DISASSEMBLY	7-29
REASSEMBLY AND REMOUNTING	7-30
TIRE AND WHEEL	7-33
TIRE REMOVAL	7-33
INSPECTION	7-35
TIRE MOUNTING	7-36
REAR SUSPENSION	7-38
SWINGARM	7-38
SHOCK ABSORBER AND CUSHION LEVER	7-39
REMOVAL	7-40
INSPECTION	7-41
DISASSEMBLY	7-42
REASSEMBLY INFORMATION	7-44
REASSEMBLY AND REMOUNTING	7-45
FINAL INSPECTION AND ADJUSTMENT	7-46
SHOCK ABSORBER SPRING PRE-LOAD	7-46

FRONT WHEEL



REMOVAL

- Support the motorcycle with the center stand and jack.
- Remove the brake caliper by removing the mounting bolts.

09900-00410 : Hexagon wrench set

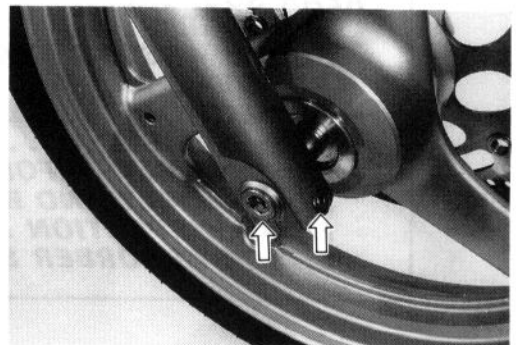
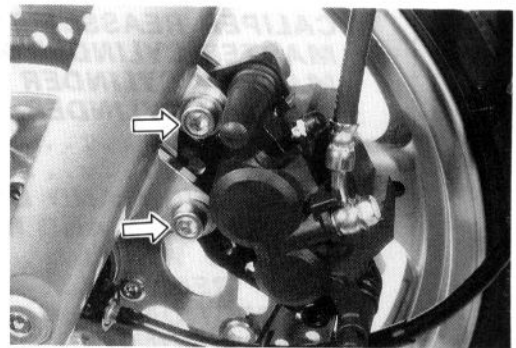
NOTE:

Do not operate the brake lever while removing the front wheel.

CAUTION:

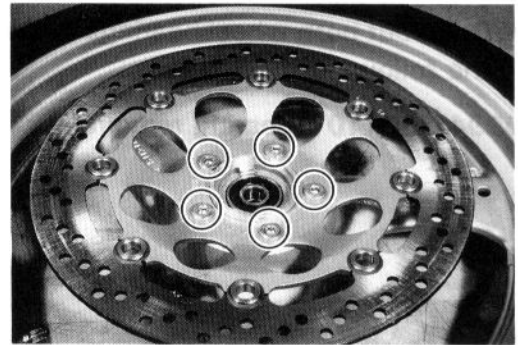
Hang the brake caliper from the motorcycle frame by using the string, etc., taking care not to bend the brake hose.

- Loosen the axle pinch bolt.
- Remove the axle shaft and front wheel.



- Remove the brake disc off the front wheel by removing the mounting bolts.

09900-00410 : Hexagon wrench set



INSPECTION AND DISASSEMBLY SPEEDOMETER GEAR BOX DUST SEAL

Inspect the lip of dust seal for damage.

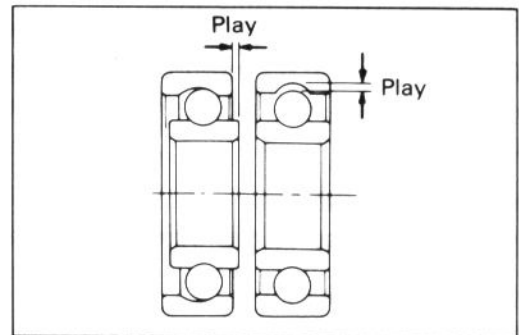
TIRE

Refer to page 7-33.



WHEEL BEARINGS

Inspect the play of the wheel bearings by hand while they are in the wheel. Rotate the inner race by hand to inspect for abnormal noise and smooth rotation. Replace the bearing if there is anything unusual.



AXLE SHAFT

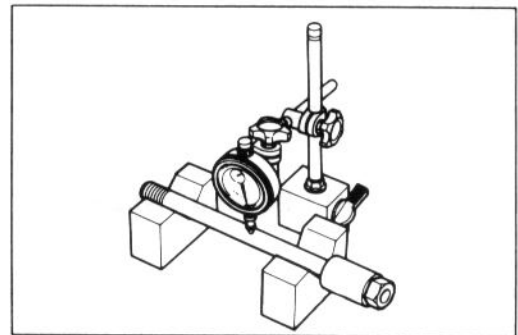
Using a dial gauge, check the axle shaft for runout and replace it if the runout exceeds the limit.

09900-20606 : Dial gauge (1/100)

09900-20701 : Magnetic stand

09900-21304 : V-block set (100 mm)

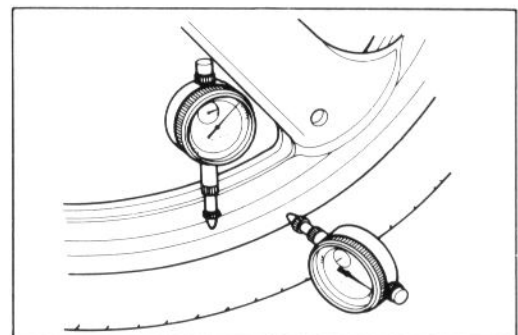
Service limit : 0.25 mm (0.010 in)



WHEEL

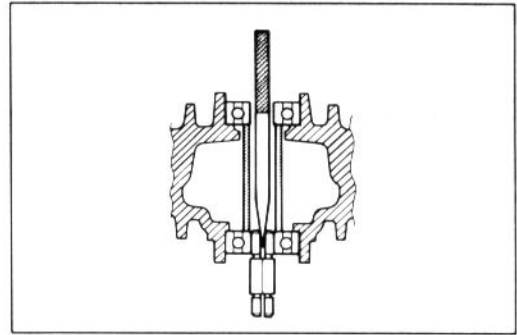
Make sure that the wheel runout checked as shown does not exceed the service limit. An excessive runout is usually due to worn or loosen wheel bearings and can be reduced by replacing the bearings. If bearing replacement fails to reduce the runout, replace the wheel.

Service limit (Axial and Radial) : 2.0 mm (0.08 in)



- Drive out both wheel bearings by using the special tool in the following procedures.

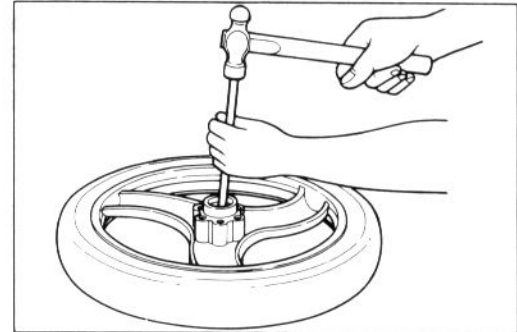
09941-50110 : Bearing remover



- Insert the adaptor into the wheel bearing.
- After inserting the wedge bar from the opposite side, lock the wedge bar in the slit of the adaptor.
- Drive out the wheel bearing by knocking the wedge bar.

CAUTION:

The removed bearings should be replaced with new ones.



REASSEMBLY AND REMOUNTING

Reassemble and remount the front wheel in the reverse order of removal and disassembly. Pay attention to the following points:

WHEEL BEARING

- Apply grease to the bearing before installing.

(For U.S.A. model)

99000-25030 : SUZUKI SUPER GREASE "A"

(For the other models)

99000-25010 : SUZUKI SUPER GREASE "A"

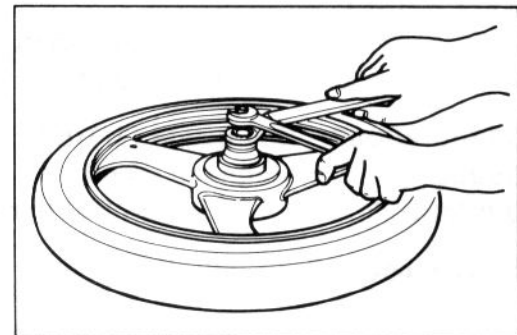


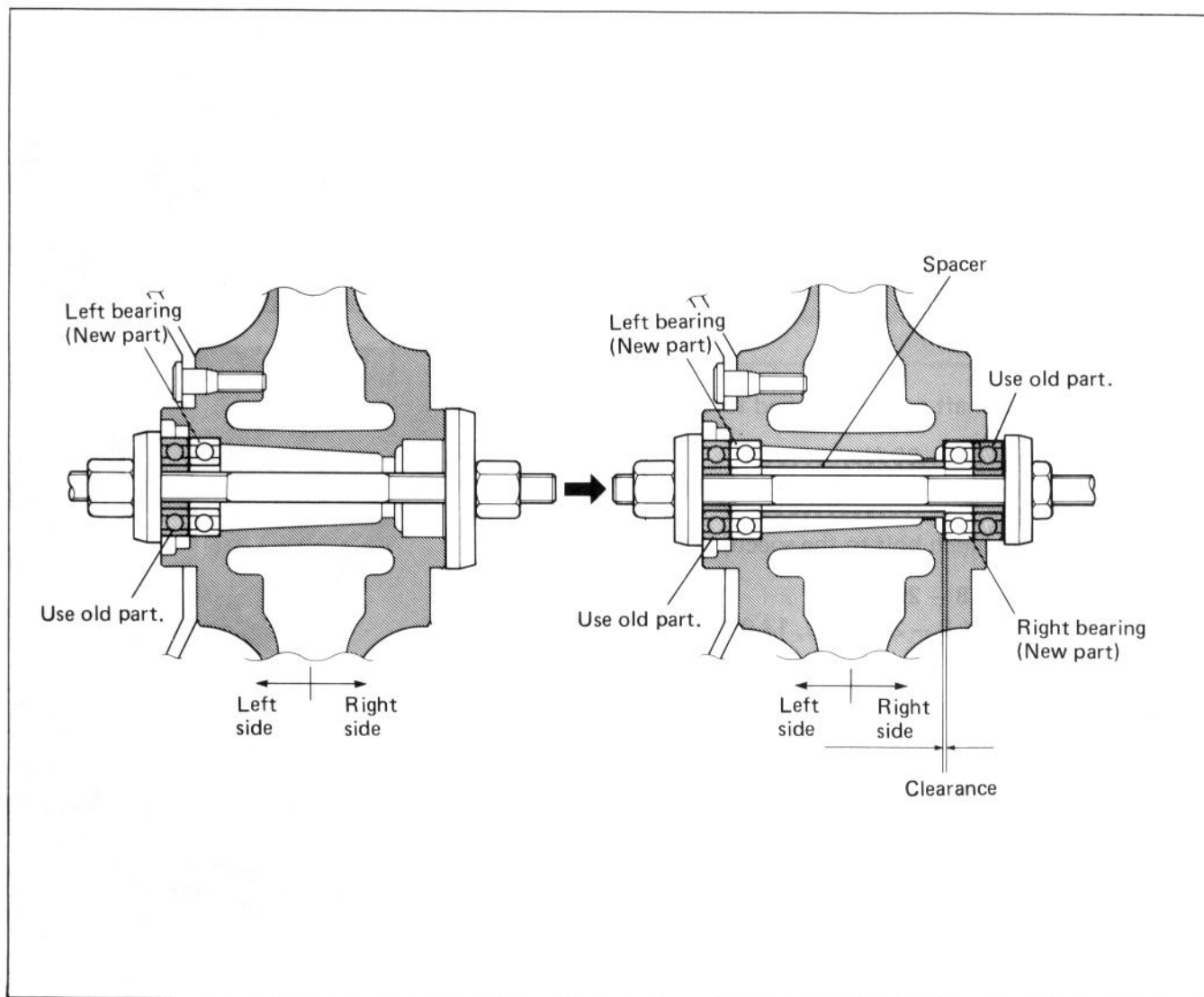
- Install the wheel bearings as follows by using the special tool.

09924-84510 : Bearing installer set

NOTE:

First install the left wheel bearing, then install the right wheel bearing. The sealed cover on the bearing is positioned outside. Refer to the illustration on next page.



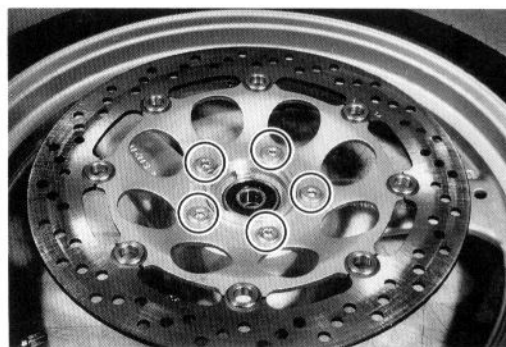


BRAKE DISC

- Make sure that the brake disc is clean and free of any greasy matter. Apply **THREAD LOCK SUPER "1360"** to the disc mounting bolts and tighten them to the specified torque.

Tightening torque : 18 – 28 N·m
(1.8 – 2.8 kg·m, 13.0 – 20.0 lb-ft)

99000-32130 : THREAD LOCK SUPER "1360"



SPEEDOMETER GEARBOX

- Before installing the speedometer gearbox, apply grease to its dust seal lip.

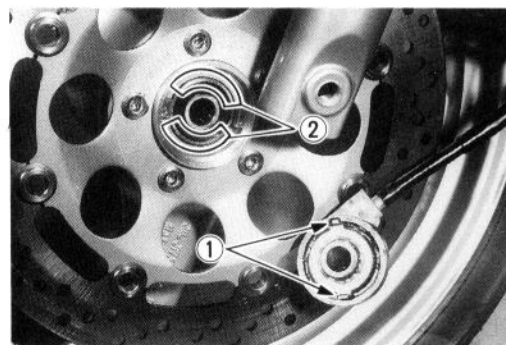
(For U.S.A. model)

99000-25030 : SUZUKI SUPER GREASE "A"

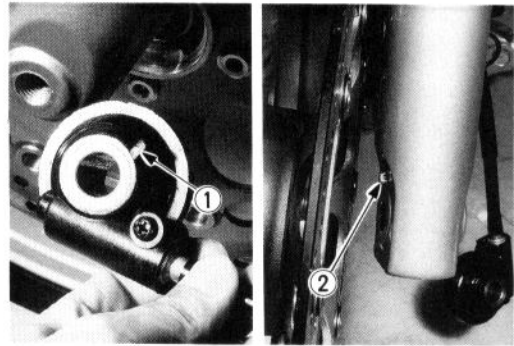
(For the other models)

99000-25010 : SUZUKI SUPER GREASE "A"

- Fit the drive lugs ① into the recesses ② of the wheel hub.



- Set the stopper ① on the speedometer gearbox to lug ② on the left front fork.
- When tightening the front axle, make sure that the speedometer gearbox is in position and the speedometer cable does not bend sharply.



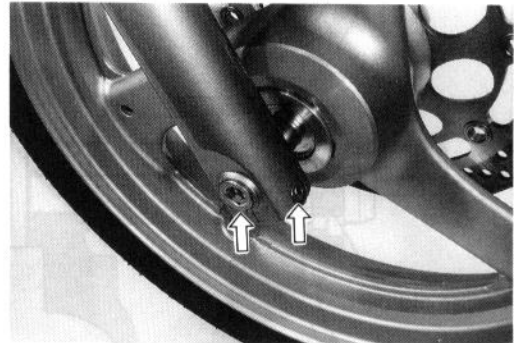
AXLE SHAFT

- Tighten the axle shaft to the specified torque.

Tightening torque : 50 – 80 N·m
(5.0 – 8.0 kg-m, 36.0 – 58.0 lb-ft)

- Tighten the axle pinch bolt to the specified torque.

Tightening torque : 18 – 28 N·m
(1.8 – 2.8 kg-m, 13.0 – 20.0 lb-ft)



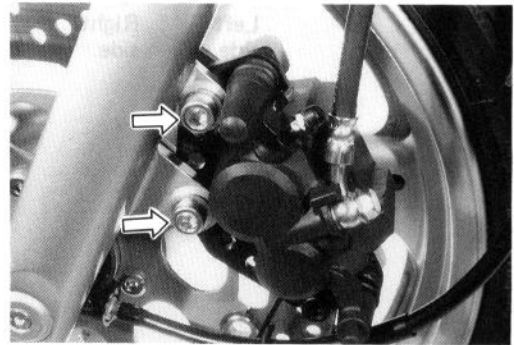
BRAKE CALIPER

- Tighten the brake caliper mounting bolts to the specified torque.

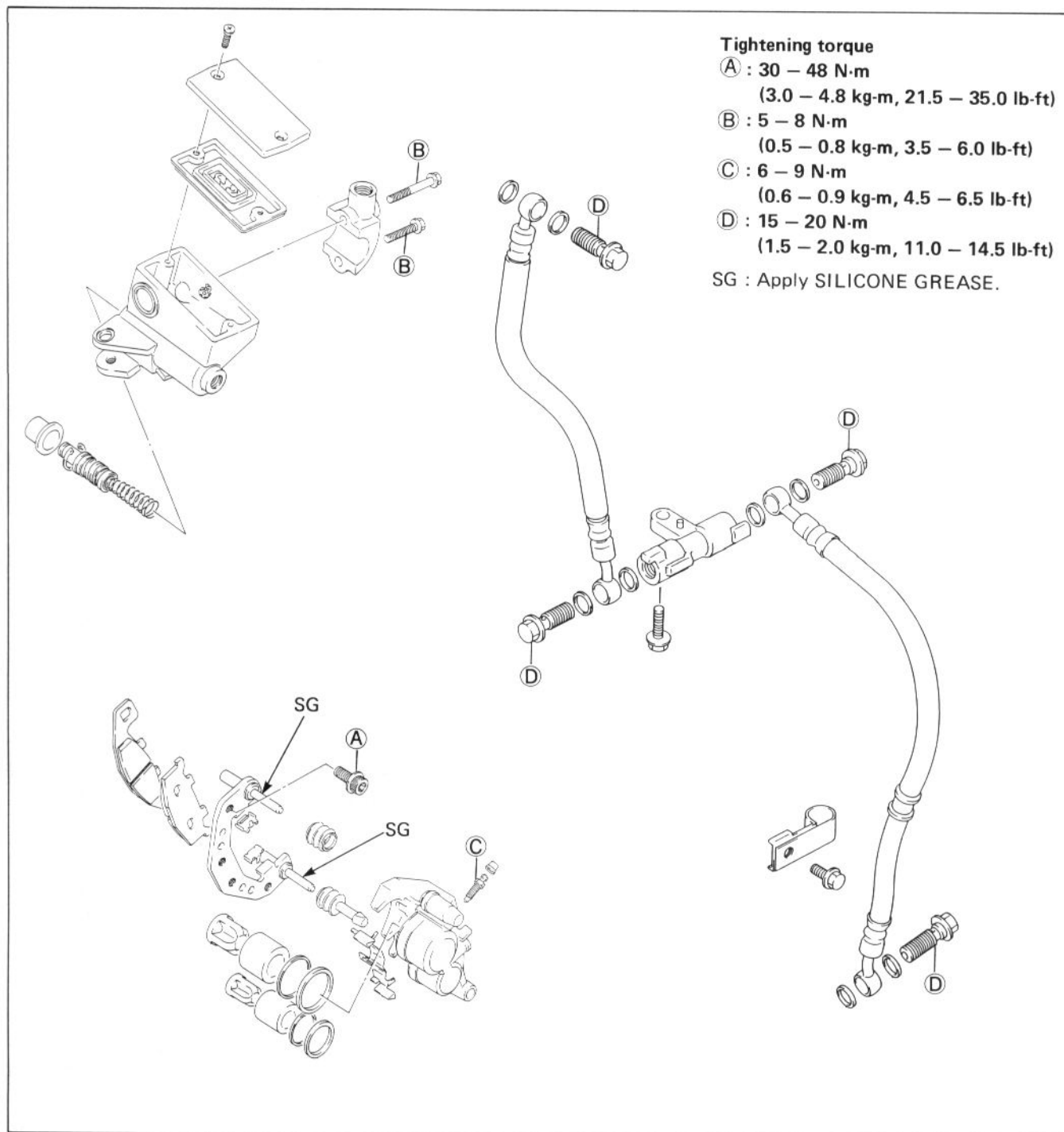
Tightening torque : 30 – 48 N·m
(3.0 – 4.8 kg-m, 21.5 – 35.0 lb-ft)

NOTE:

Push the pistons all the way into the caliper and remount the caliper.



FRONT BRAKE

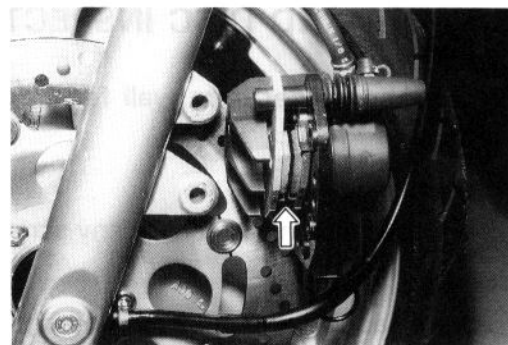


BRAKE PAD REPLACEMENT

- Remove the brake caliper by removing the mounting bolts.
- Remove the pads.

CAUTION:

- * Do not operate the brake lever while removing the pads.
- * Replace the brake pad as a set, otherwise braking performance will be adversely affected.



CALIPER REMOVAL AND DISASSEMBLY

- Disconnect the brake hose by removing the union bolt and catch the brake fluid in a suitable receptacle.

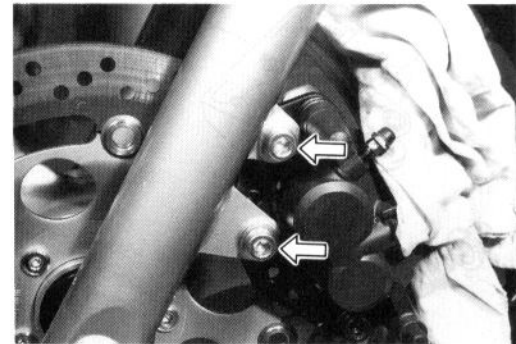
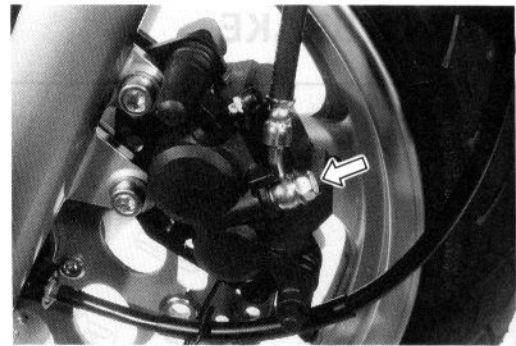
CAUTION:

Never re-use the brake fluid left over from the previous servicing and stored for long periods.

WARNING:

Brake fluid, if it leaks, will interfere with safe running and discolor painted surfaces. Check the brake hose and hose joints for cracks and oil leakage.

- Remove the caliper mounting bolts and take off the caliper.
- Remove the pads.



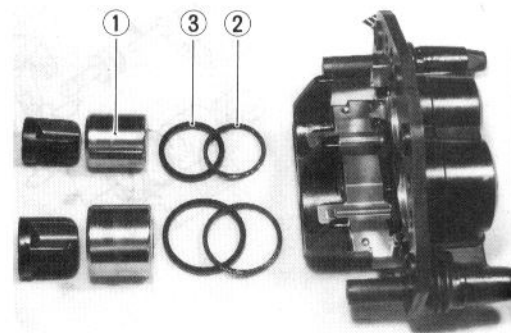
- Place a rag over the pistons to prevent them from popping out and push out the piston by using an air gun.

CAUTION:

Do not use high pressure air to prevent piston damage.



- Remove the piston ①, dust seal ② and piston seal ③ out of the caliper.



CALIPER AND DISC INSPECTION

CALIPER

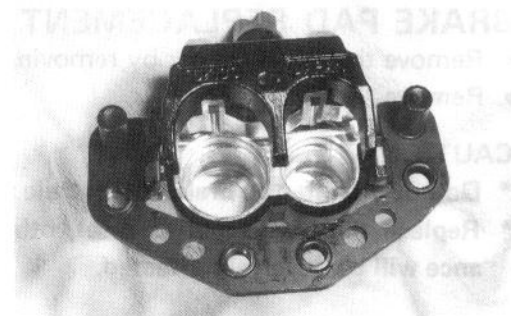
Inspect the caliper bore wall for nicks, scratches or other damage.

PISTON

Inspect the piston surface for any scratches or other damage.

RUBBER PARTS

Inspect each rubber part for damage and wear.

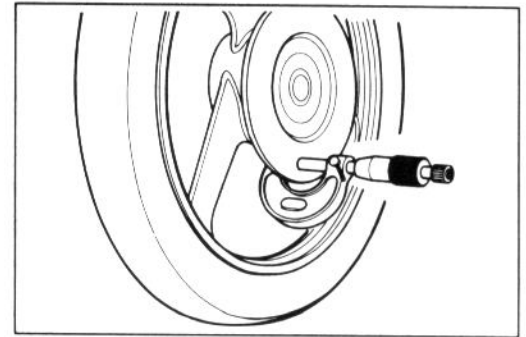


DISC

Using a micrometer, check the disc for wear, its thickness can be checked with disc and wheel in place. The service limits for the thickness of the discs are shown below.

09900-20205 : Micrometer (0 – 25 mm)

Service limit (Front) : 4.0 mm (0.16 in)
(Rear) : 5.5 mm (0.22 in)

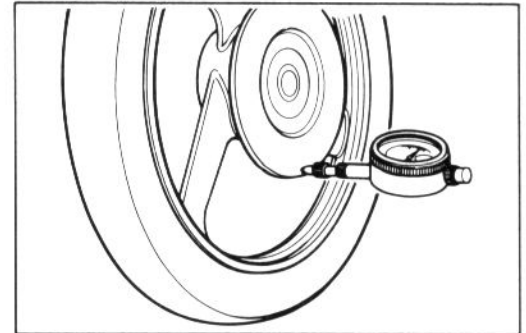


With the disc mounted on the wheel, check the disc for face runout with a dial gauge, as shown.

09900-20606 : Dial gauge (1/100 mm)

09900-20701 : Magnetic stand

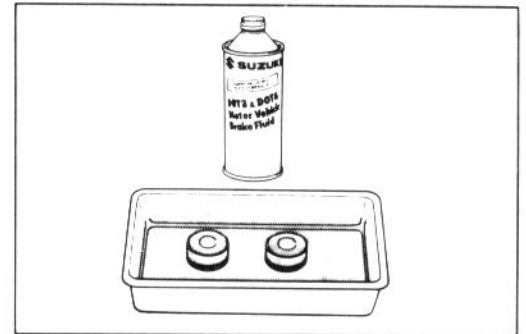
Service limit : 0.30 mm (0.012 in)

**CALIPER REASSEMBLY AND REMOUNTING**

Reassemble and remount the caliper in the reverse order of removal and disassembly. Pay attention to the following points:

CAUTION:

- * Wash the caliper components with fresh brake fluid before reassembly.
- * Never use cleaning solvent or gasoline to wash them.
- * Apply brake fluid to the caliper bore and piston to be inserted into the bore.

**CALIPER BOLTS**

Tighten each bolt to the specified torque.

(Refer to page 7-6.)

CAUTION:

Bleed air from the brake system after reassembling the caliper.
(Refer to page 2-14.)

NOTE:

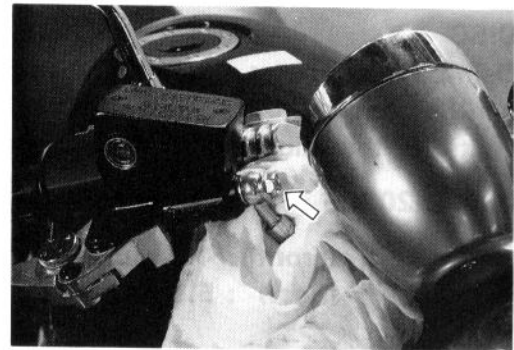
Before remounting the caliper, push the piston all the way into the caliper.

MASTER CYLINDER REMOVAL AND DISASSEMBLY

- Remove the front brake light switch.



- Place a rag underneath the union bolt on the master cylinder to catch spilled drops of brake fluid. Unscrew then union bolt and disconnect the brake hose/master cylinder joint.



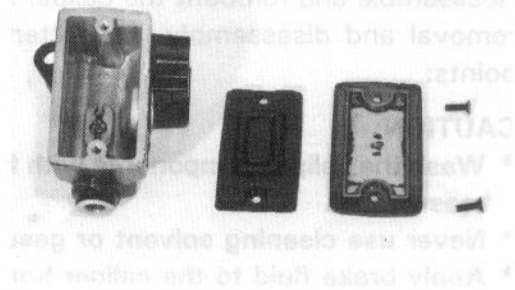
CAUTION:

Completely wipe off any brake fluid adhering to any parts of the motorcycle. The fluid reacts chemically with paint, plastics, rubber materials, etc.

- Remove the master cylinder assembly.

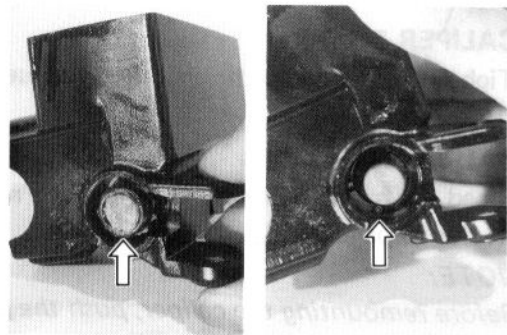


- Remove the front brake lever, reservoir cap and diaphragm.
- Drain brake fluid.



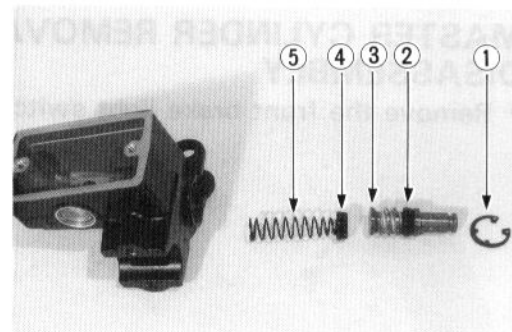
- Remove the dust seal, then remove the circlip by using the special tool.

09900-06108 : Snap ring pliers



- Remove the piston/secondary cup, primary cup and spring.

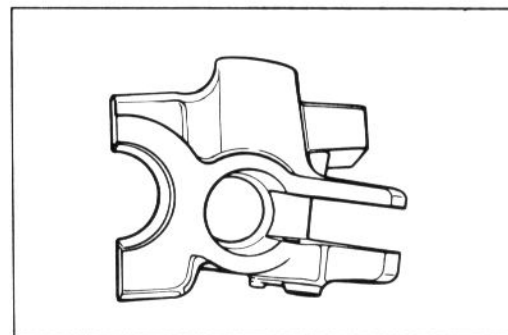
- ① Circlip
- ② Secondary cup
- ③ Piston
- ④ Primary cup
- ⑤ Return spring



MASTER CYLINDER INSPECTION

Inspect the master cylinder bore for any scratches or other damage.

Inspect the piston surface for any scratches or other damage. Inspect the primary cup, secondary cup and dust seal for wear or damage.



MASTER CYLINDER REASSEMBLY AND REMOUNTING

Reassemble and remount the master cylinder in the reverse order of removal and disassembly. Pay attention to the following points:

CAUTION:

Wash the master cylinder components with fresh brake fluid before reassembly. Never use cleaning solvent or gasoline to wash them. Apply brake fluid to the cylinder bore and all the parts to be inserted into the bore.

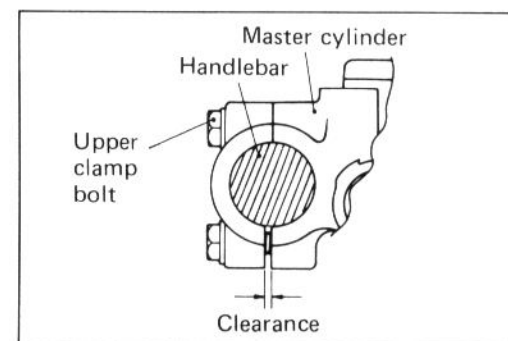
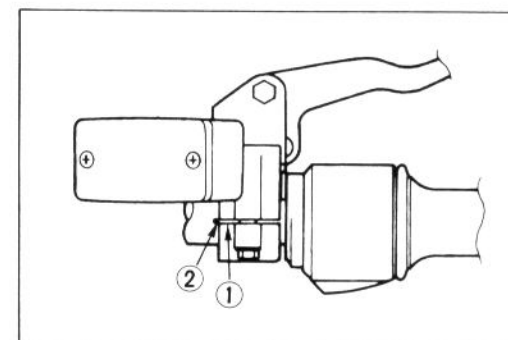
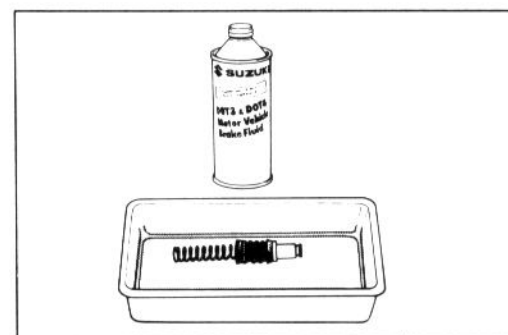
- When remounting the master cylinder on the handlebar, align the master cylinder holder's mating surface ① with punched mark ② on the handlebar and tighten the upper clamp bolt first as shown.

Tightening torque : 5 – 8 N·m
(0.5 – 0.8 kg·m, 3.5 – 6.0 lb·ft)

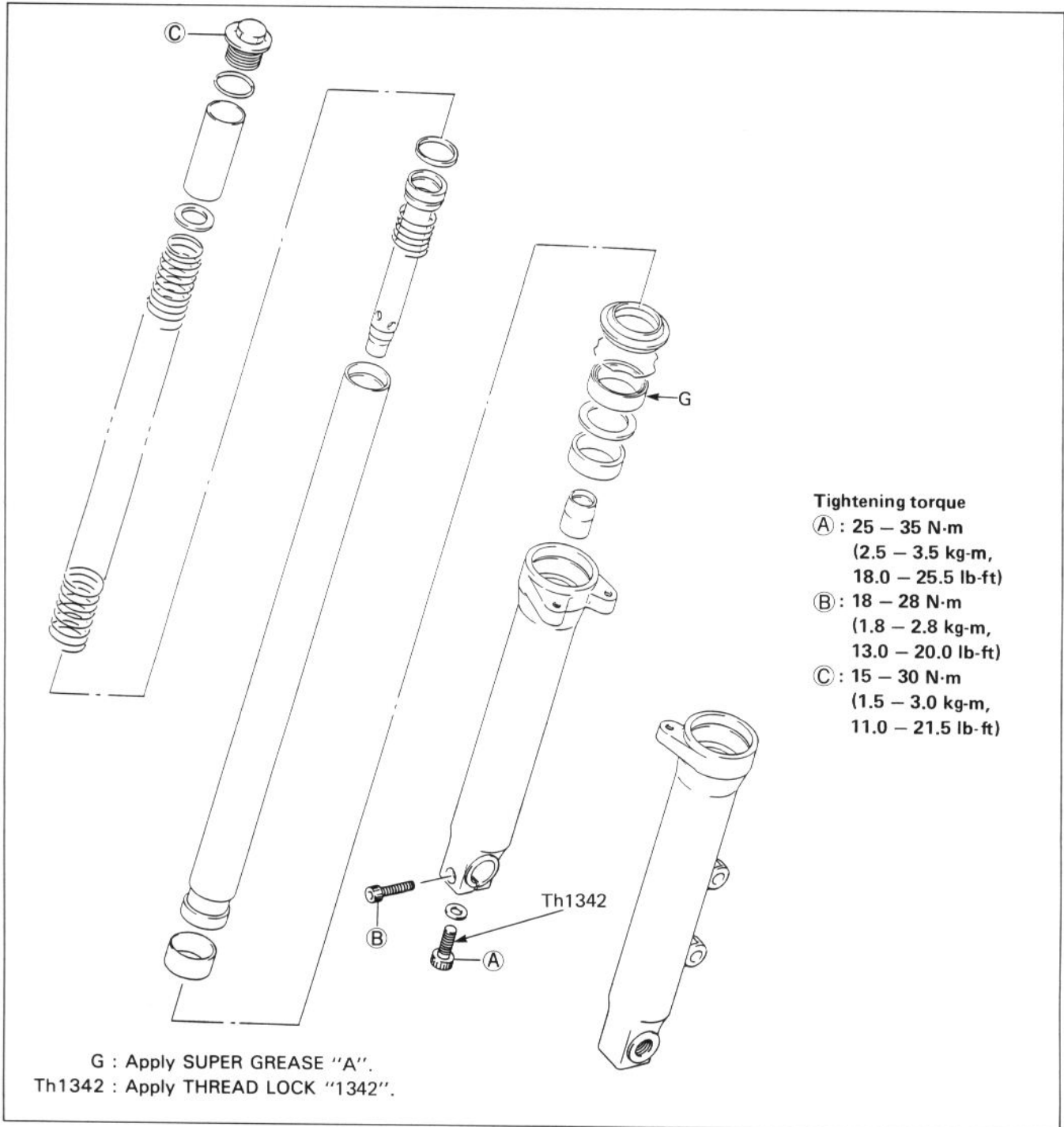
CAUTION:

Bleed air from the brake system after reassembling master cylinder. (Refer to page 2-14.)

Adjust the front brake light switch after installation.



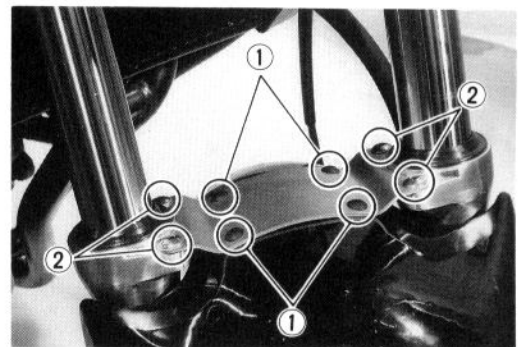
FRONT FORK



REMOVAL

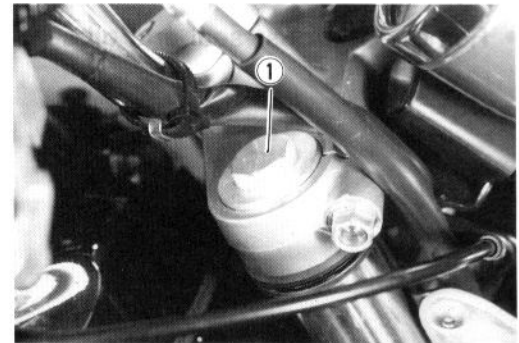
- Remove the front wheel. (Refer to page 7-1.)
- Remove the front fender by removing four screws ①.
- Remove the front fender brace by removing four screws ②.

09900-00401 : L-type hexagon wrench

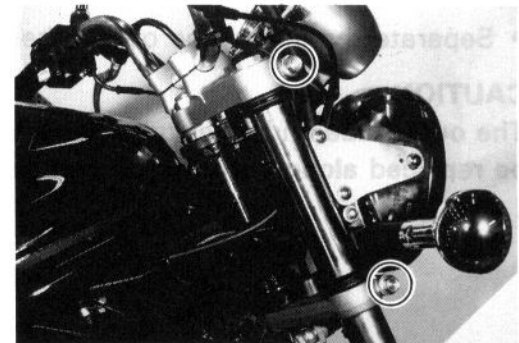


NOTE:

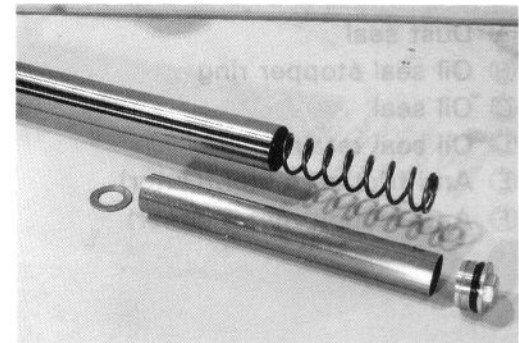
Slightly loosen the front fork cap bolt ① to facilitate later disassembly before loosening the front fork clamp bolt.



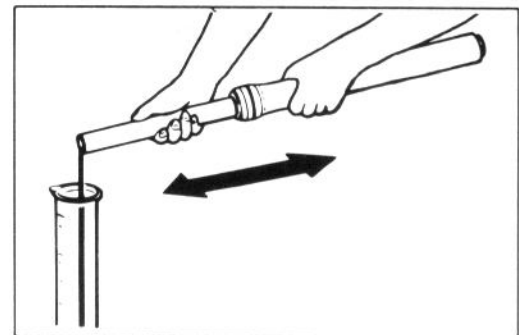
- Loosen the front fork upper and lower clamp bolts.
- Pull down the front forks.

**DISASSEMBLY**

- Remove the front fork cap bolt.
- Remove the spacer, spring seat and spring out of the inner tube.



- Invert the fork and stroke it several times to let out fork oil.
- Hold the fork inverted for a few minutes to drain oil.

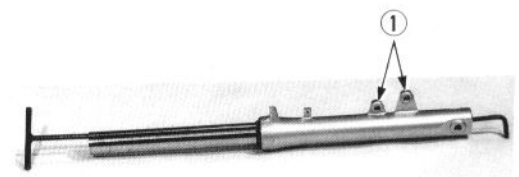


- While holding the caliper mounting portion ① by vise and remove the damper rod with the special tool and the hexagon wrench.

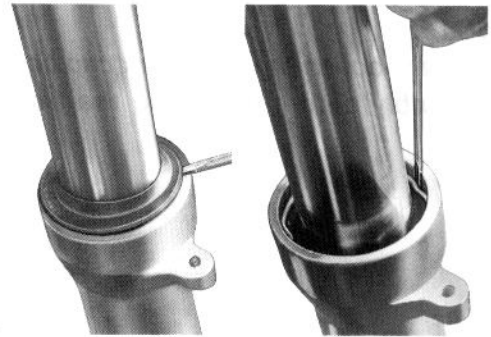
09900-00401 : "L" type hexagon wrench set

09940-34520 : T-handle

09940-34592 : Attachment "G"



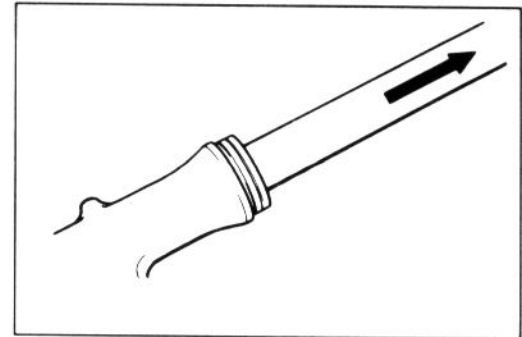
- Remove the dust seal and oil seal stopper ring.



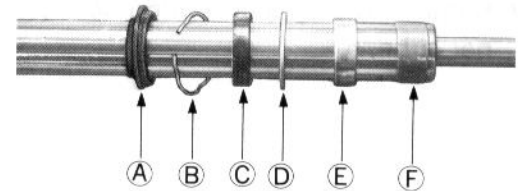
- Separate the inner tube out of the outer tube.

CAUTION:

The outer tube and inner tube "anti-friction" metals must be replaced along with the oil seal and dust seal.



- Ⓐ Dust seal
- Ⓑ Oil seal stopper ring
- Ⓒ Oil seal
- Ⓓ Oil seal retainer
- Ⓔ Anti-friction metal (Outer)
- Ⓕ Anti-friction metal (Inner)



- Remove the damper rod and rebound spring out of the inner tube.



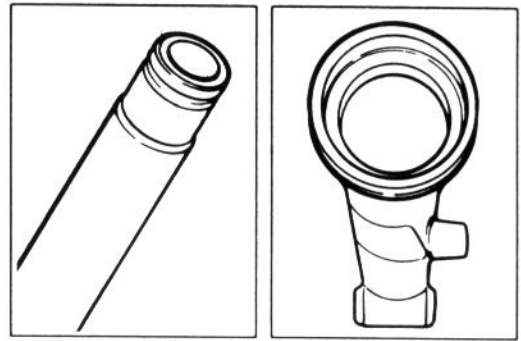
**INSPECTION
DAMPER ROD RING**

Inspect the damper rod ring for wear or damage.



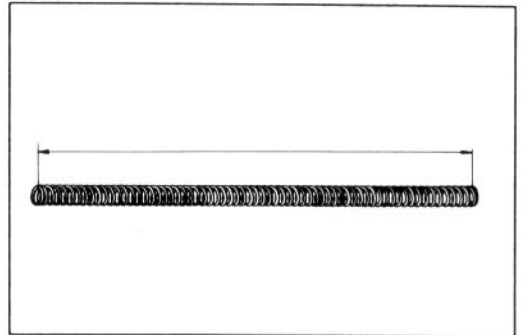
INNER AND OUTER TUBES

Inspect the inner tube sliding surface and outer tube sliding surface for any scuffing.

**FORK SPRING**

Measure the fork spring free length. If it is shorter than the service limit, replace it with a new one.

Service limit : 262 mm (10.3 in)

**REASSEMBLY AND REMOUNTING**

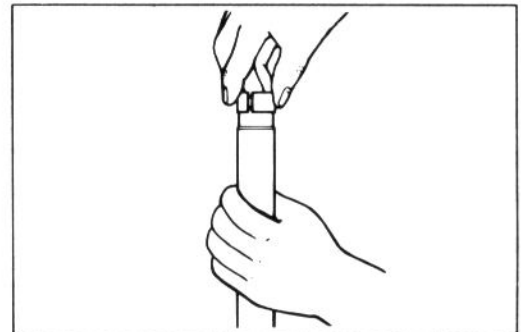
Reassemble and remount the front fork in the reverse order of removal and disassembly. Pay attention to the following points:

INNER TUBE METAL

- Hold the inner tube vertically and clean the metal groove and install the metal by hand as shown.

CAUTION:

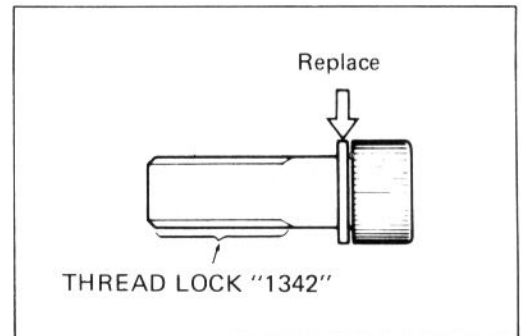
Use special care to prevent damage to the "Teflon" coated surface of the "anti-friction" metal when installing it.

**DAMPER ROD BOLT**

- Replace the gasket with a new one. Apply THREAD LOCK "1342" to the damper rod bolt and tighten it to the specified torque.

99000-32050 : THREAD LOCK "1342"

Tightening torque : 25 – 35 N·m
(2.5 – 3.5 kg·m, 18.0 – 25.5 lb-ft)

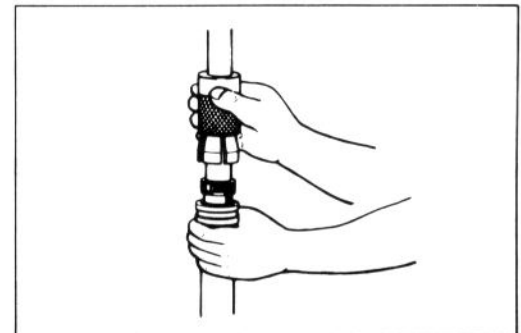
**OUTER TUBE METAL, OIL SEAL AND DUST SEAL**

- Clean the metal groove of outer tube and metal outer surface.
- Install the outer tube metal, oil seal retainer and oil seal.

09940-50113 : Front fork oil seal installer

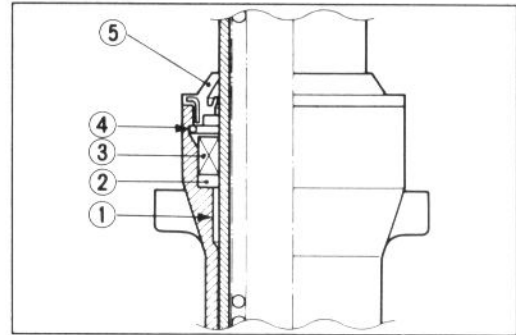
CAUTION:

Use special care to prevent damage to the "Teflon" coated surface of the "anti-friction" metal when installing it.



- After installing the oil seal, install the oil stopper ring and dust seal.

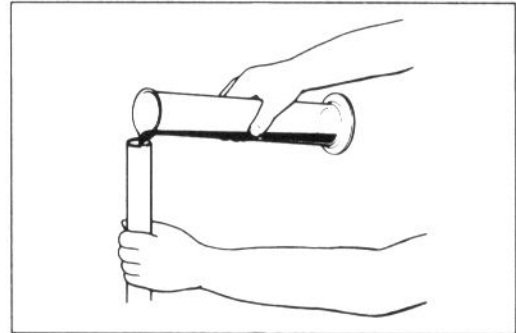
- ① Anti-friction metal
- ② Oil seal retainer
- ③ Oil seal
- ④ Oil seal stopper ring
- ⑤ Dust seal



FORK OIL

- Use fork oil whose viscosity rating meets the specifications below.

Fork oil type	For oil # 10
Fork oil capacity (For E-03, 28 and 33)	494 ml (16.7/17.4 US/Imp oz)
Fork oil capacity (For the others)	495 ml (16.7/17.4 US/Imp oz)



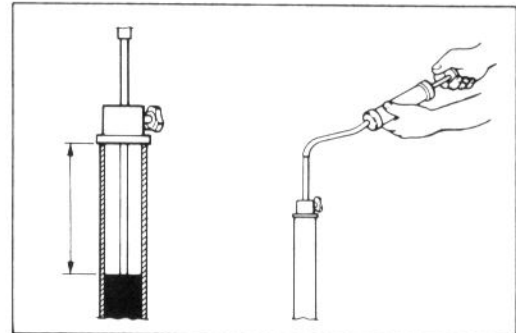
- Hold the front fork vertically and adjust the fork oil level with the special tool.

NOTE:

When adjusting oil level, remove the fork spring and compress the inner tube fully.

09943-74111 : Fork oil level gauge

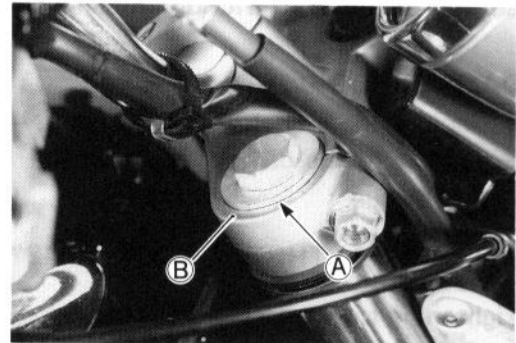
Fork oil level	For E-03, 28 and 33	106 mm (4.17 in)
	For the others	105 mm (4.13 in)



- Tighten the front fork cap bolt to the specified torque. (Refer to page 7-11.)

FRONT FORK REINSTALLATION

- When installing the front fork assembly, set the upper surface ① of inner tube to the upper surface ② of the steering stem head bracket.



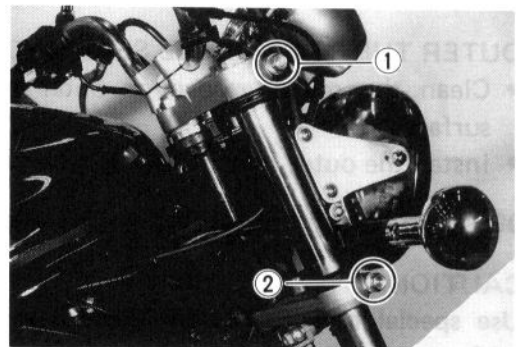
FRONT FORK CLAMP BOLTS

- Tighten the front fork upper and lower clamp bolts to the specified torque.

09900-00410 : Hexagon wrench set

TIGHTENING TORQUE

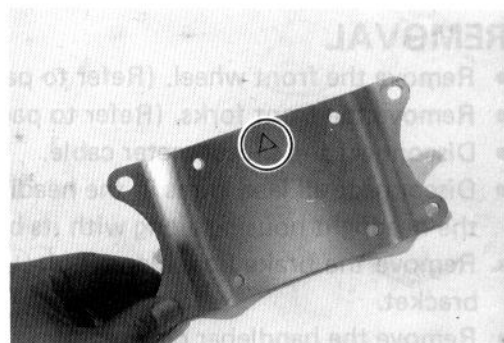
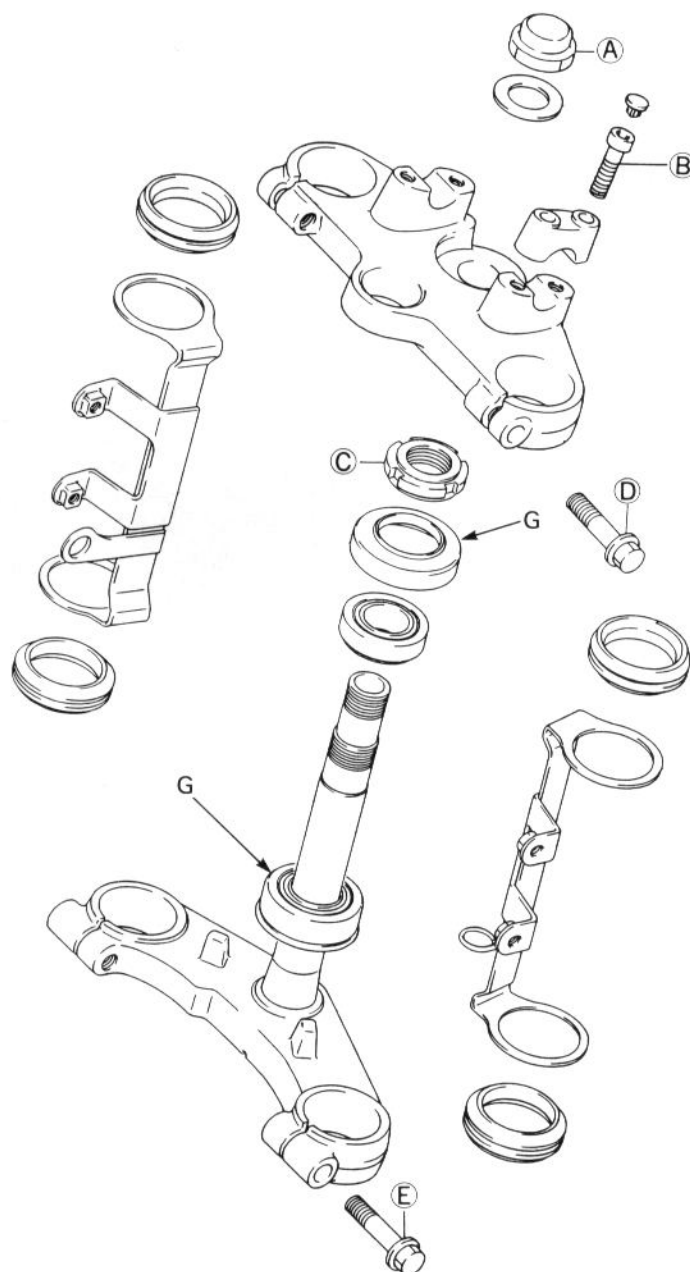
- ① (Front fork upper clamp bolt):
40 – 60 N·m (4.0 – 6.0 kg·m, 29.0 – 43.5 lb-ft)
- ② (Front fork lower clamp bolt):
28 – 44 N·m (2.8 – 4.4 kg·m, 20.0 – 32.0 lb-ft)



- The triangle mark on the fender brace faces front side.

NOTE:

Before tightening the front fender brace mounting screws, move the front fork up and down 4 or 5 times.

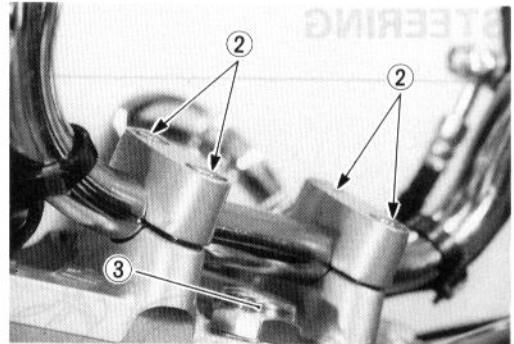
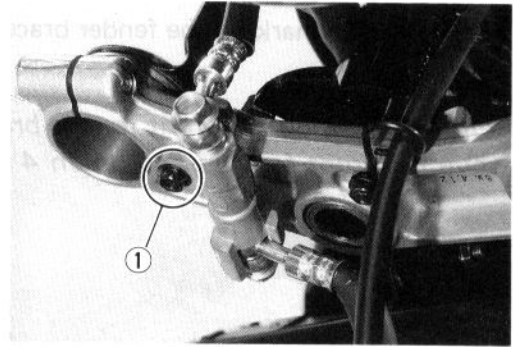
**STEERING****Tightening torque**

- Ⓐ : 50 – 80 N·m
(5.0 – 8.0 kg-m, 36.0 – 58.0 lb-ft)
- Ⓑ : 18 – 28 N·m
(1.8 – 2.8 kg-m, 13.0 – 20.0 lb-ft)
- Ⓒ : 40 – 50 N·m
(4.0 – 5.0 kg-m, 29.0 – 36.0 lb-ft)
- Ⓓ : 40 – 60 N·m
(4.0 – 6.0 kg-m, 29.0 – 43.5 lb-ft)
- Ⓔ : 28 – 44 N·m
(2.8 – 4.4 kg-m, 20.0 – 32.0 lb-ft)

G : Apply SUPER GREASE "A".

REMOVAL

- Remove the front wheel. (Refer to page 7-1.)
- Remove the front forks. (Refer to page 7-11.)
- Disconnect the speedometer cable.
- Disconnect all lead wires in the headlight housing and remove the headlight housing along with its brackets.
- Remove the brake hose clamp bolt ① from the steering lower bracket.
- Remove the handlebar clamp bolts ②.
- Remove the steering stem head nut ③.
- Remove the steering stem head bracket along with the tachometer, speedometer and ignition switch.

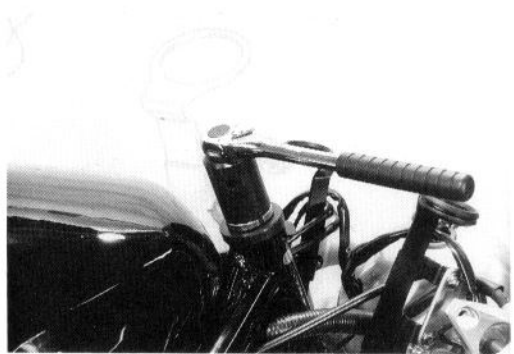


- Remove the steering stem nut by using the special tool, then remove the steering stem lower bracket.

09940-14911 : Steering stem nut wrench

NOTE:

Hold the steering stem lower bracket by hand to prevent it from falling.



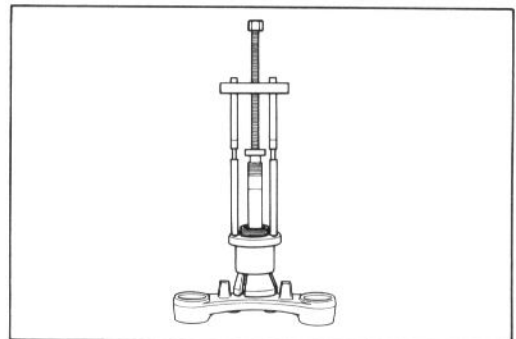
DISASSEMBLY

- Remove the steering stem lower bearing by using the special tools.

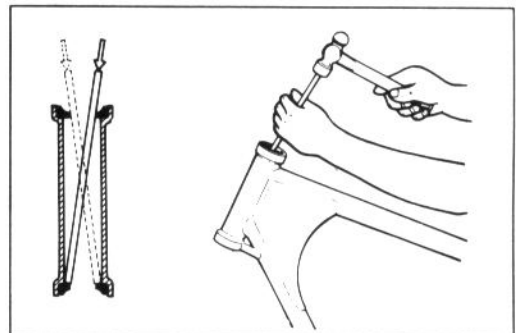
09941-84510 : Bearing remover

CAUTION:

The removed bearing should be replaced.



- Drive out the steering stem bearing races, upper and lower, by using an appropriate drift.



INSPECTION

Inspect the removed parts for the following abnormalities.

- * Handlebar distortion
- * Handlebar clamp wear
- * Race wear and brinelling
- * Bearing wear or damage
- * Abnormal noise of bearing
- * Distortion of steering stem

REASSEMBLY AND REMOUNTING

Reassemble and remount the steering stem in the reverse order of removal and disassembly. Pay attention to the following points:

OUTER RACES

- Press in the upper and lower outer races by using the special tool.

09941-34513 : Steering outer race installer

BEARING

- Place a washer on the bearing and press in the lower bearing by using the special tool.

09941-74910 : Steering bearing installer

- Apply grease to the upper and lower bearings before re-mounting the steering stem.

(For U.S.A. model)

99000-25030 : SUZUKI SUPER GREASE "A"

(For the other models)

99000-25010 : SUZUKI SUPER GREASE "A"

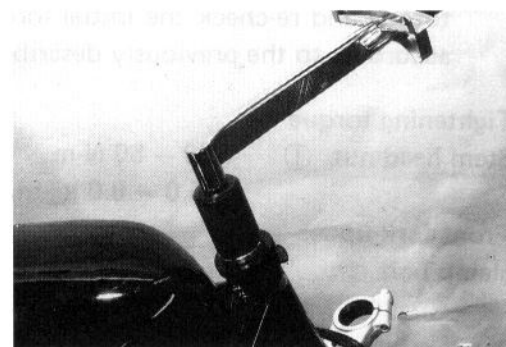
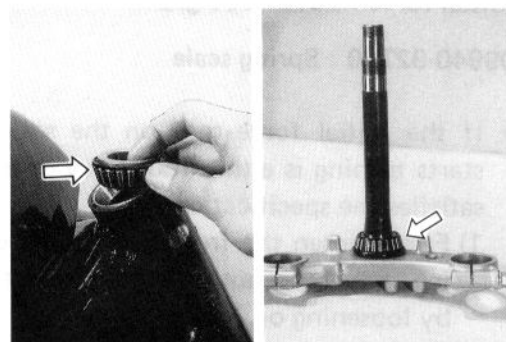
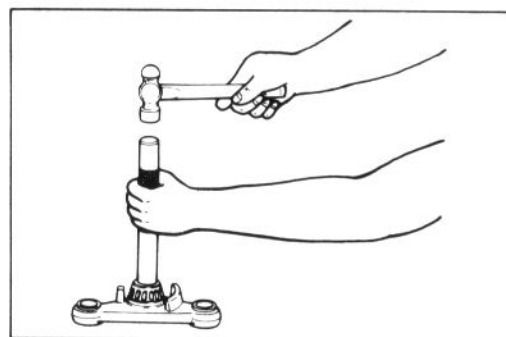
STEM NUT

- Tighten the steering stem nut to the specified torque.

09940-14911 : Steering stem nut wrench

Tightening torque : 40 – 50 N·m

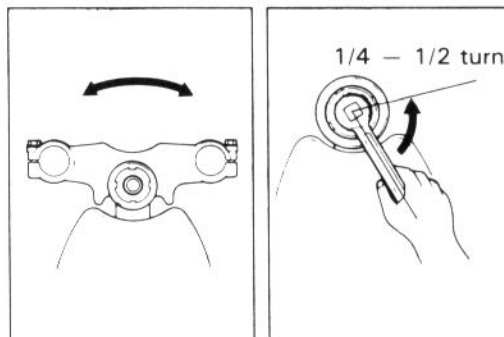
(4.0 – 5.0 kg-m, 29.0 – 36.0 lb-ft)



- Turn the steering stem lower bracket about five or six times to the left and right so that the taper roller bearing will be seated properly.
- Turn back the stem nut by 1/4 – 1/2 turn.

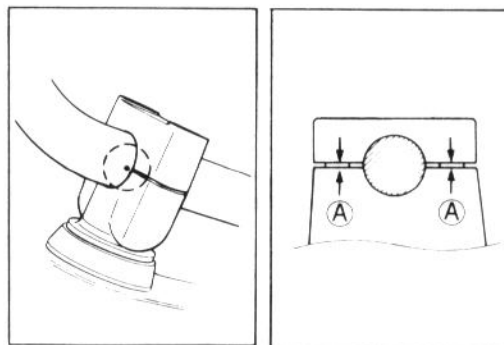
NOTE:

This adjustment will vary from motorcycle to motorcycle.



HANDLEBAR

- Set the handlebar to match its punched mark to the mating face of the holder.
- Secure the each handlebar clamp in such a way that the clearances (A) ahead and behind the handlebar are equalized.



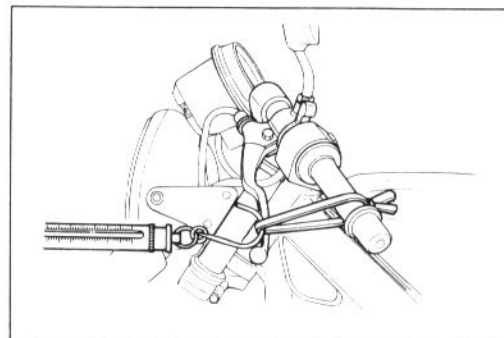
Tightening torque : 18 – 28 N·m

(1.8 – 2.8 kg·m, 13.0 – 20.0 lb-ft)

STEERING TENSION ADJUSTMENT

Check the steering movement in the following procedure.

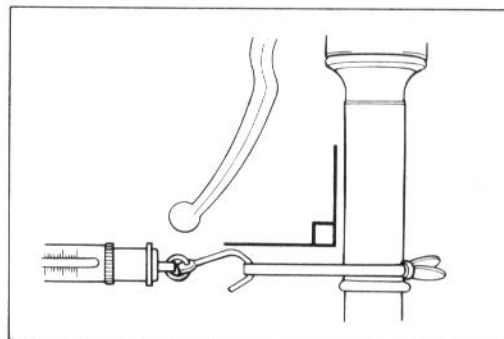
- By supporting the motorcycle with the center stand and a jack, lift the front wheel until it is off the floor by 20 – 30 mm (0.8 – 1.2 in).
- Check to make sure that the cables and wire harnesses are properly routed.
- With the front wheel in the straight ahead state, hitch the spring scale (special tool) on one handlebar grip end as shown in the figure and read the graduation when the handlebar starts moving. Do the same on the other grip end.



Initial force : 200 – 500 grams

09940-92710 : Spring scale

- If the initial force read on the scale when the handlebar starts turning is either too heavy or too light, adjust it till it satisfies the specification.
 - 1) First, loosen the front fork upper clamp bolts and steering stem head nut, and then adjust the steering stem nut by loosening or tightening it.
 - 2) Tighten the head nut and clamp bolts to the specified torque and re-check the initial force with the spring scale according to the previously described procedure.



Tightening torque

Stem head nut ① : 50 – 80 N·m
(5.0 – 8.0 kg·m, 36.0 – 58.0 lb-ft)

Front fork upper clamp bolt ② : 40 – 60 N·m
(4.0 – 6.0 kg·m, 29.0 – 43.5 lb-ft)

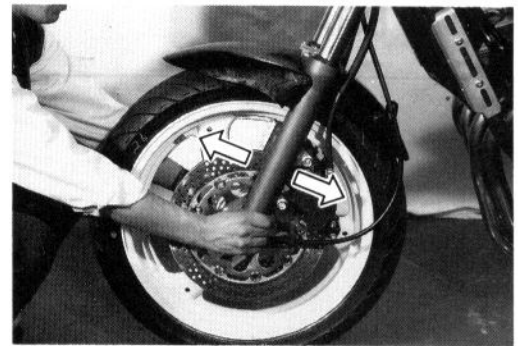
- 3) If the initial force is found within the specified range, adjustment has been completed.



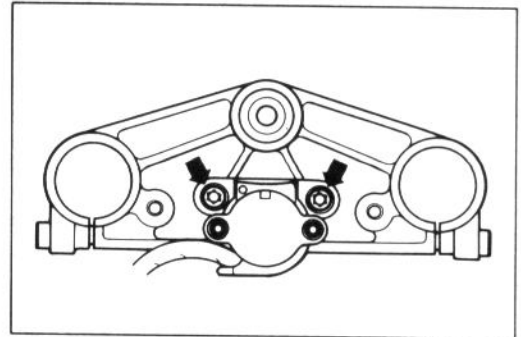
NOTE:

Hold the front fork legs, move them back and forth and make sure that the steering is not loose.

- Lower the jack.

**IGNITION SWITCH**

- To remove the ignition switch, remove the bolt to detach the ignition switch from the steering stem upper bracket by using a center punch and hammer.



- To install the ignition switch, always use the new special bolt and follow the procedures below.

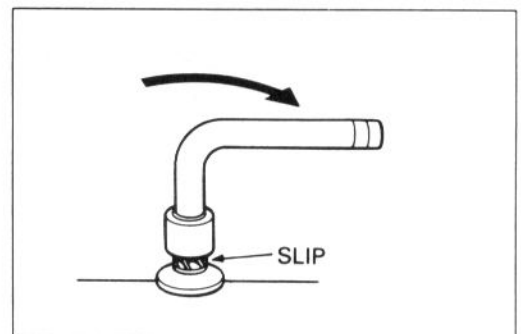
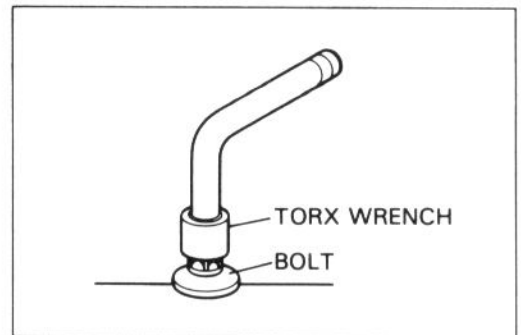
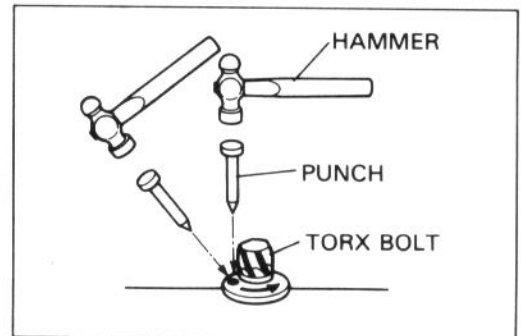
NOTE:

The spare ignition switch comes equipped with the special bolts, however, the bolt is also individually available as spare parts.

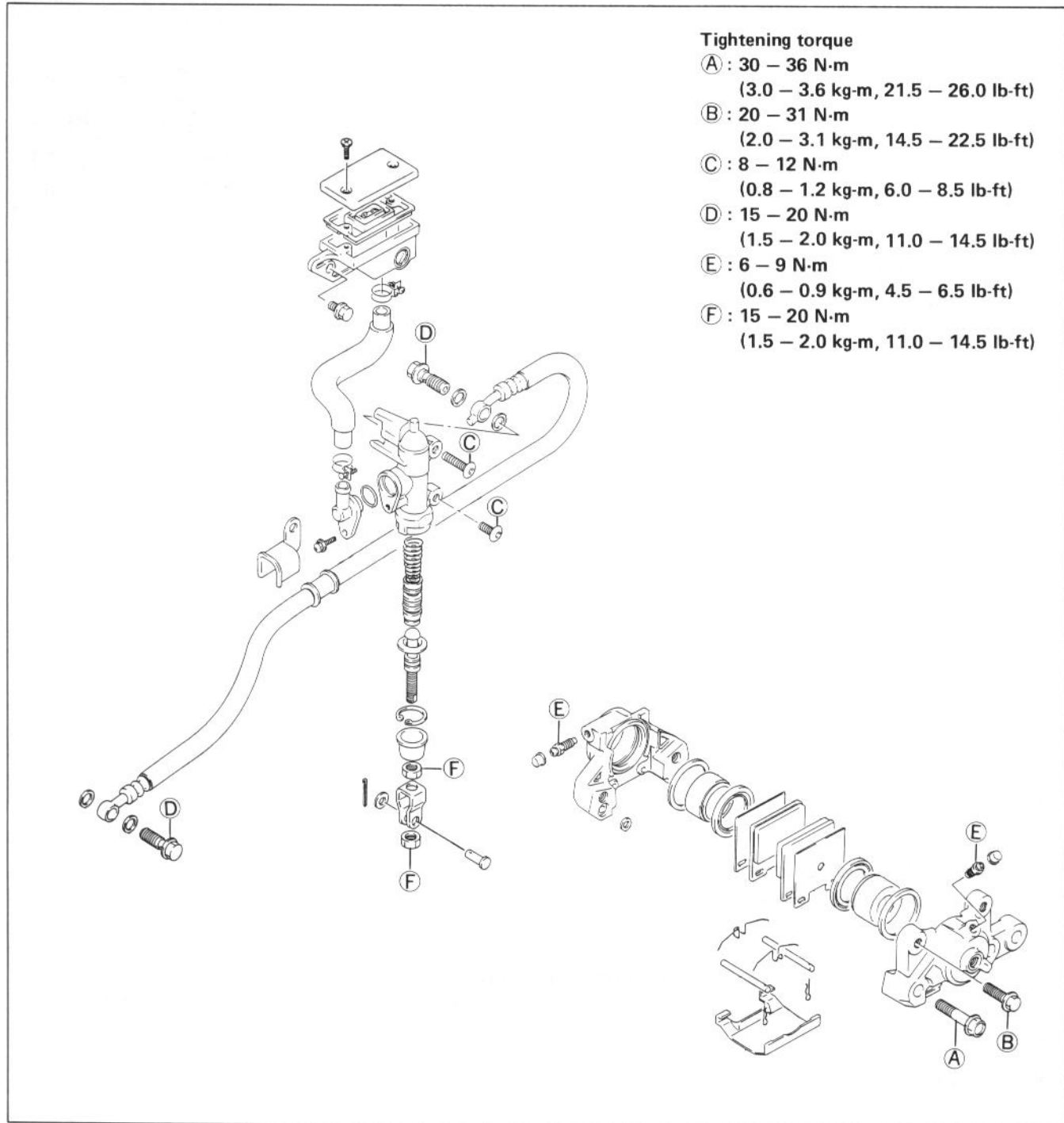
- Using the special bolts, attach the ignition switch on the steering stem upper bracket in place and run in the bolts with the special tool.

09930-11910 : Torx wrench

- Continue turning the tool until the tool slips from the bolt head or the bolt head breaks off, then the bolt has become tightened to the proper specification.



REAR BRAKE

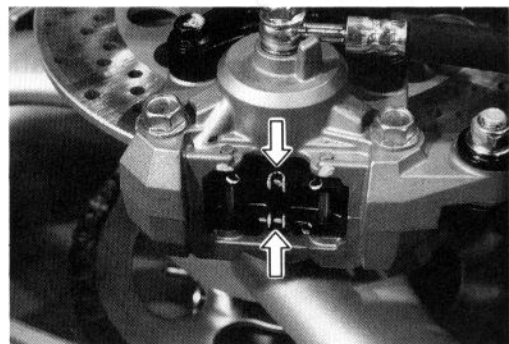


BRAKE PAD REPLACEMENT

- Remove the dust seal cover.
- Remove the clips, pins and springs.
- Remove the pads.

CAUTION:

- * Do not operate the brake pedal while removing the pads.
- * Replace the brake pad as a set, otherwise braking performance will be adversely affected.



CALIPER REMOVAL AND DISASSEMBLY

- Remove the brake hose union bolt and catch the brake fluid in a suitable receptacle.
- Remove the caliper mounting bolts.
- Remove the torque link bolt and nut, and take off the caliper.

NOTE:

Slightly loosen the caliper housing bolts to facilitate later disassembly before removing the caliper mounting bolts.

- Remove the pads. (Refer to page 7-21.)
- Remove the caliper housing bolts and separate the caliper halves.

- Remove the O-ring.

NOTE:

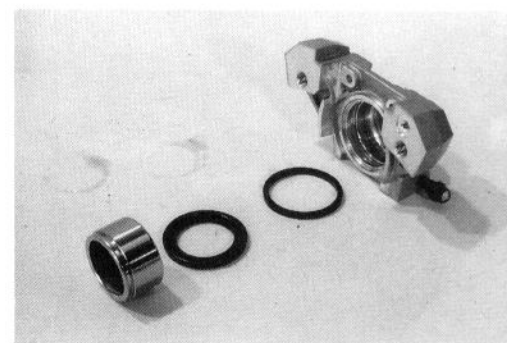
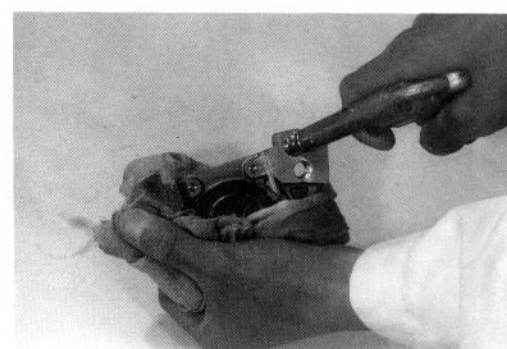
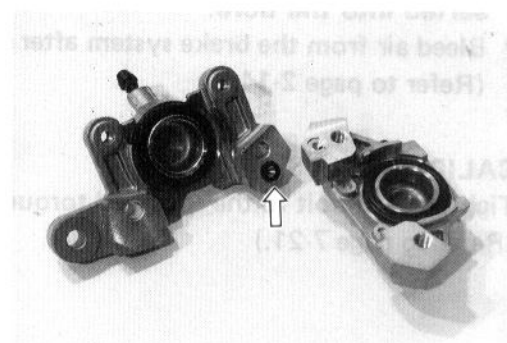
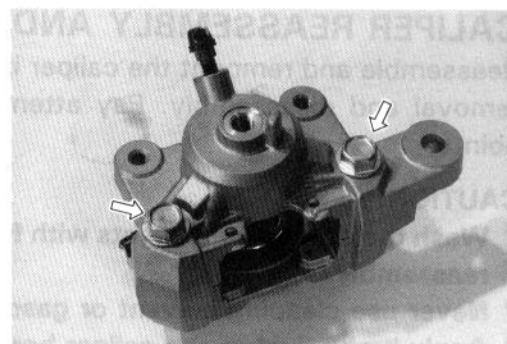
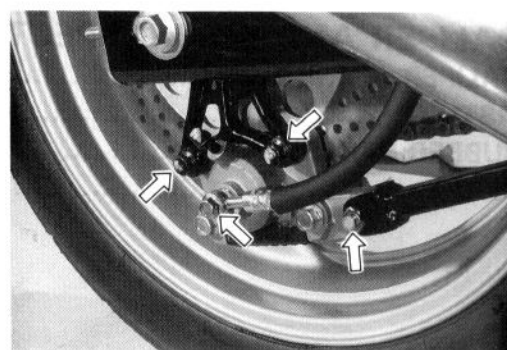
Once separate the caliper halves, replace the O-ring with a new one.

- Place a rag over the piston to prevent it from popping out and push out the piston by using an air gun.

CAUTION:

Do not use high pressure air to prevent piston damage.

- Remove the dust seal, piston and piston seal out of the caliper.



CALIPER AND DISC INSPECTION

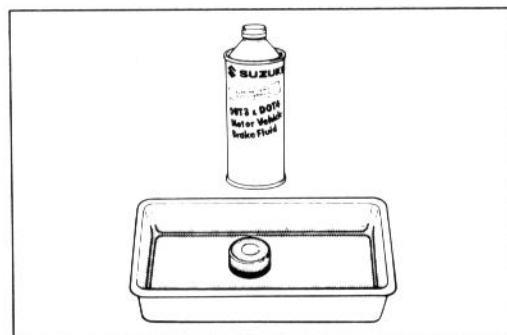
- CALIPER** Refer to page 7-7.
PISTON Refer to page 7-7.
RUBBER PARTS Refer to page 7-7.
DISC Refer to page 7-8.

CALIPER REASSEMBLY AND REMOUNTING

Reassemble and remount the caliper in the reverse order of removal and disassembly. Pay attention to the following points:

CAUTION:

- * Wash the caliper components with fresh brake fluid before reassembly.
- * Never use cleaning solvent or gasoline to wash them.
- * Apply brake fluid to the caliper bore and piston to be inserted into the bore.
- * Bleed air from the brake system after reassembling the caliper. (Refer to page 2-14.)

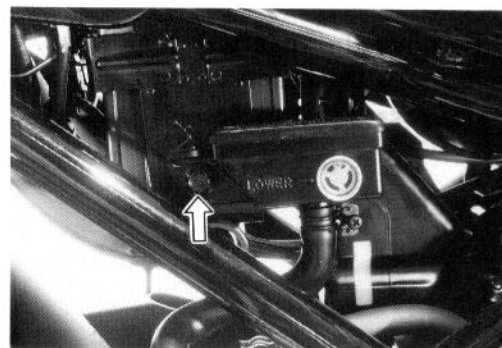


CALIPER BOLTS

Tighten each bolt to the specified torque.
(Refer to page 7-21.)

MASTER CYLINDER REMOVAL AND DISASSEMBLY

- Remove the reservoir tank mounting bolt.

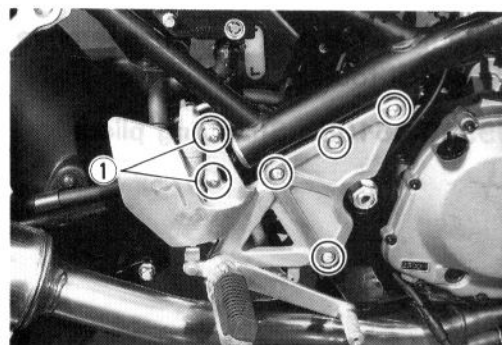


- Remove the right footrest bracket mounting bolts.

NOTE:

Slightly loosen the master cylinder mounting bolts ① before removing the right footrest bracket mounting bolts.

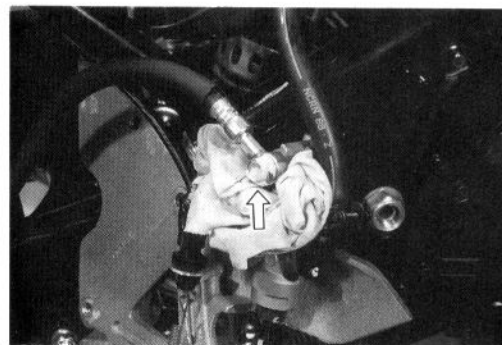
09900-00410: Hexagon wrench set



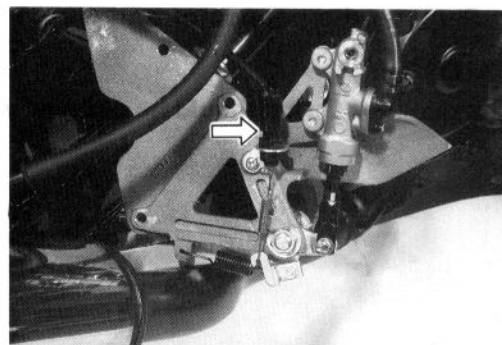
- Place a rag underneath the union bolt on the master cylinder to catch spilled drops of brake fluid. Unscrew the union bolt and disconnect the brake hose from the master cylinder joint.

CAUTION:

Immediately and completely wipe off any brake fluid contacting any part of the motorcycle. The fluid reacts chemically with paint, plastics and rubber materials, etc. and will damage them severely.

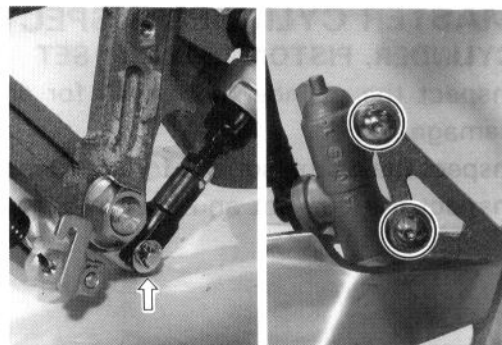


- Remove the rear brake light switch.

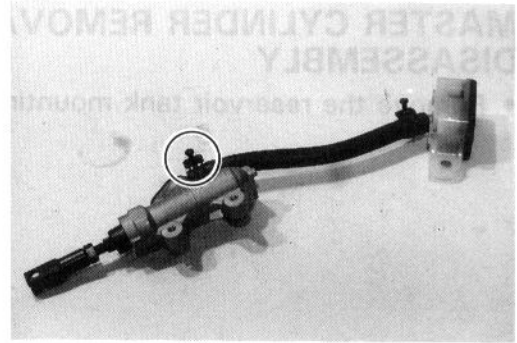


- Pull out cotter pin and remove the push rod pin.
- Remove the master cylinder from the right footrest bracket.

09900-00410: Hexagon wrench set

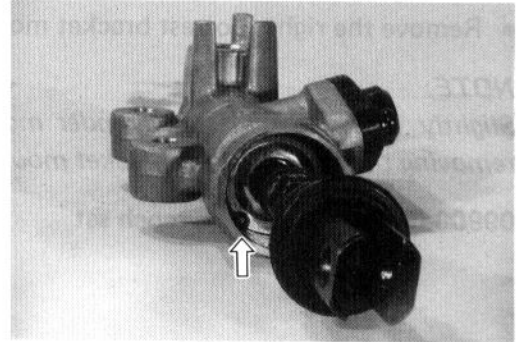


- Remove the reservoir tank hose.
- Remove the reservoir tank cap and drain brake fluid from the reservoir tank.

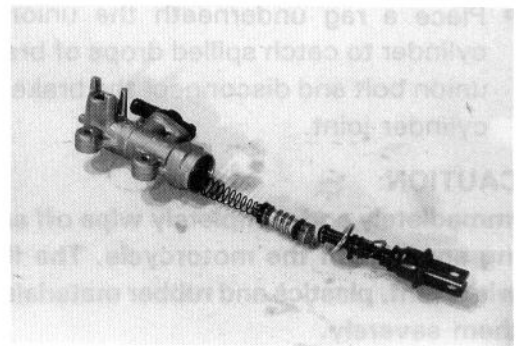


- Remove the dust seal, then remove the circlip by using the special tool.

09900-06105 : Snap ring pliers



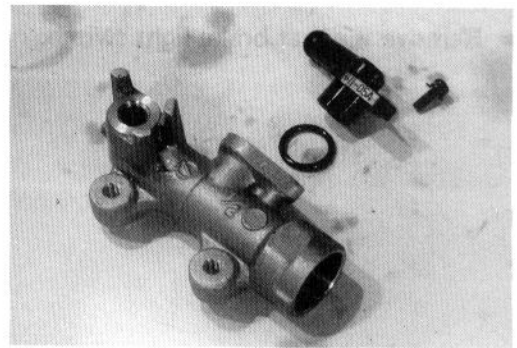
- Remove the push rod, piston, primary cup and spring.



- Remove the connector and O-ring.

CAUTION:

The removed O-ring should be replaced with a new one.



**MASTER CYLINDER INSPECTION
CYLINDER, PISTON AND CUP SET**

Inspect the cylinder bore wall for any scratches or other damage.

Inspect the piston surface for any scratches or other damage.

Inspect the cup set and each rubber part for damage.

MASTER CYLINDER REASSEMBLY AND REMOUNTING

Reassemble and remount the master cylinder in the reverse order of removal and disassembly. Pay attention to the following points:

CAUTION:

Wash the master cylinder components with fresh brake fluid before reassembly. Never use cleaning solvent or gasoline to wash them. Apply brake fluid to the cylinder bore and all the internals to be inserted into the bore.

CAUTION:

Bleed air from the brake system after reassembling master cylinder. (Refer to page 2-14.)

Adjust the rear brake light switch and brake pedal height after installation. (Refer to page 2-14.)

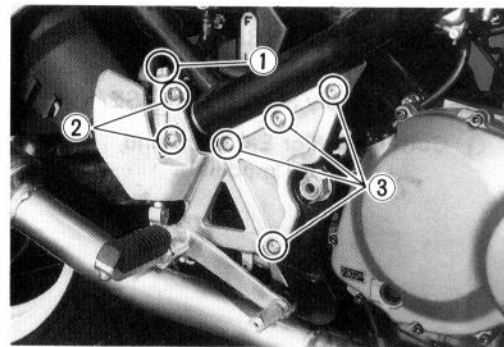
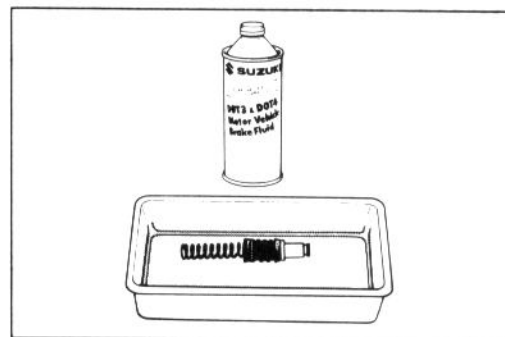
- Tighten each bolt to the specified torque.

Tightening torque

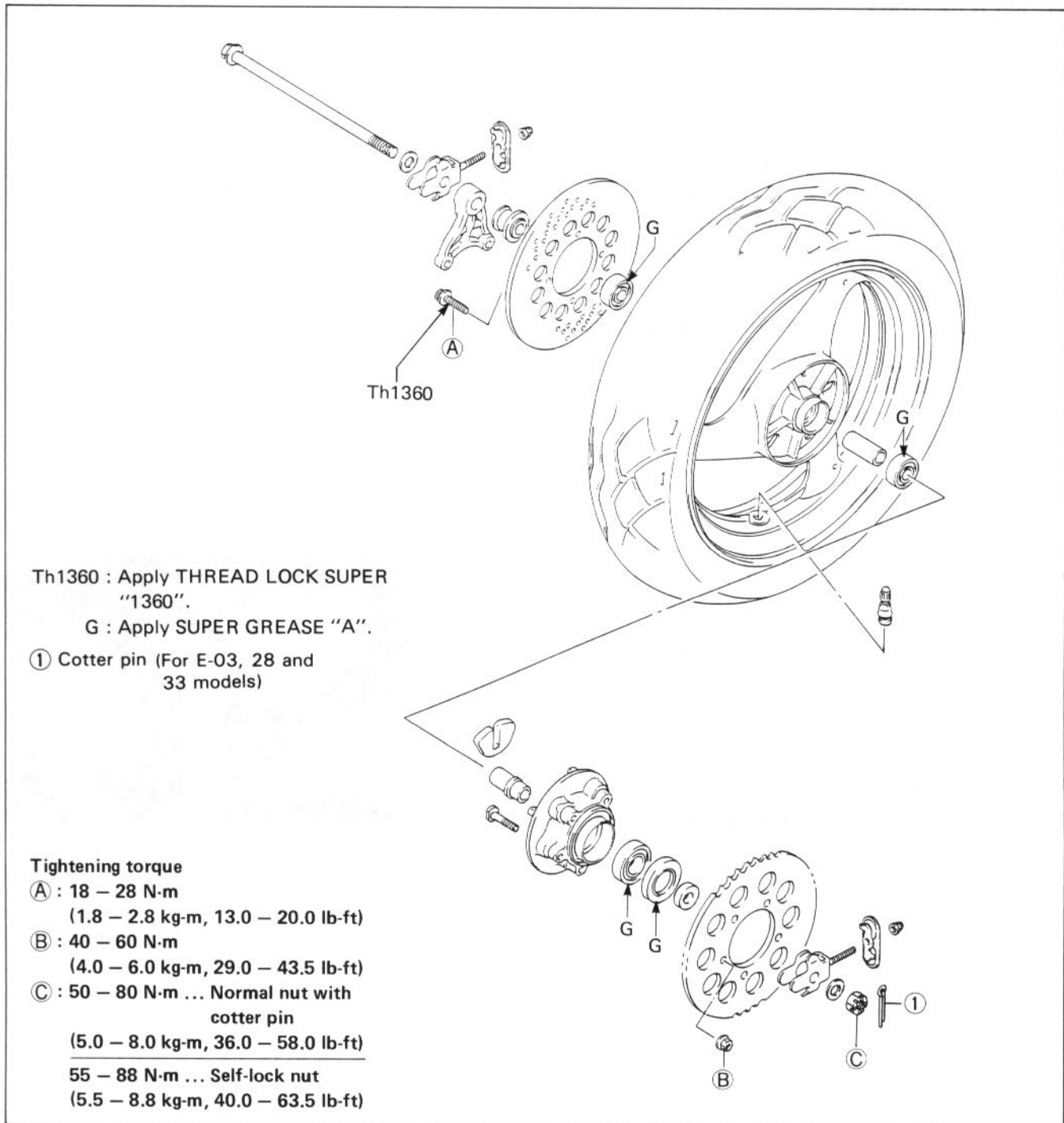
Brake hose union bolt ①: 15 – 20 N·m
(1.5 – 2.0 kg·m, 11.0 – 14.5 lb-ft)

Master cylinder mounting bolt ②: 8 – 12 N·m
(0.8 – 1.2 kg·m, 6.0 – 8.5 lb-ft)

Right footrest mounting bolt ③: 18 – 28 N·m
(1.8 – 2.8 kg·m, 13.0 – 20.0 lb-ft)



REAR WHEEL

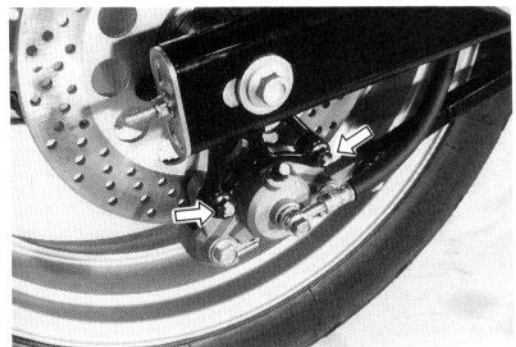


REMOVAL

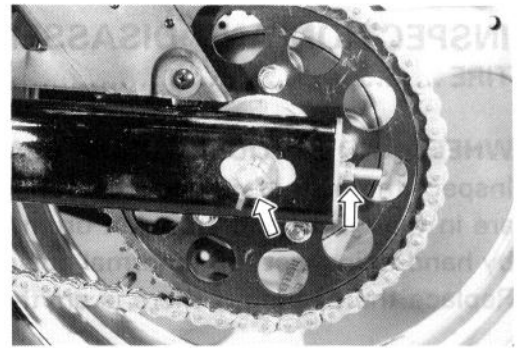
- Support the motorcycle with the center stand.
- Remove the rear brake caliper mounting bolts and lower the caliper along with the torque link.

NOTE:

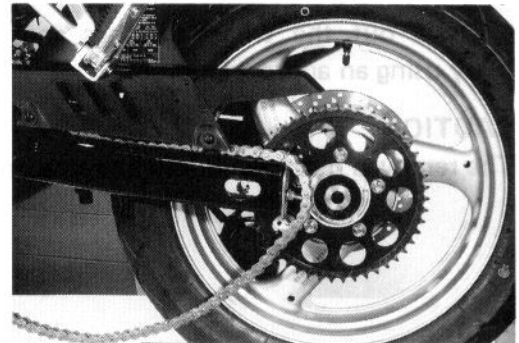
Do not operate the brake pedal while removing the rear wheel.



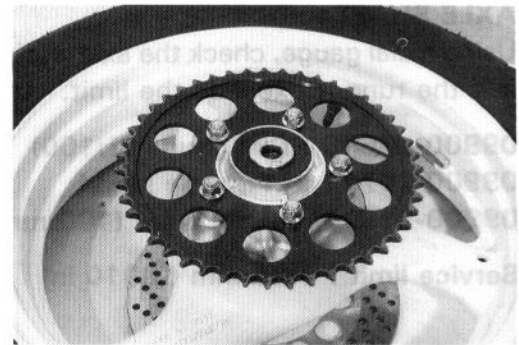
- Remove the cotter pin. (For E-03, 28 and 33 models)
- Remove the rear axle nut.
- Loosen the chain adjusting nuts, left and right.
- Draw out the axle shaft.



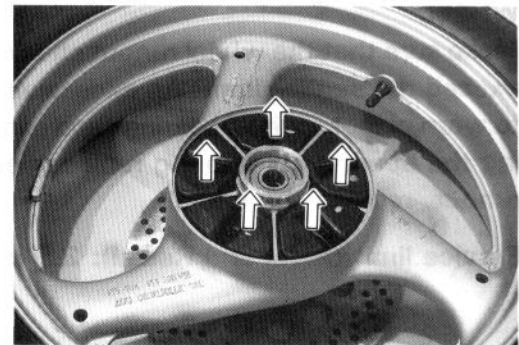
- Disengage the drive chain from the rear sprocket.
- Remove the rear wheel.



- Remove the rear sprocket along with its mounting drum off the wheel hub.

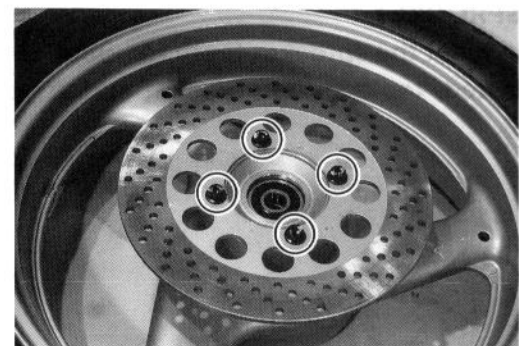


- Remove the five dampers out of the wheel hub.



- Remove the brake disc by removing the mounting bolts.

09900-00410 : Hexagon wrench set



INSPECTION AND DISASSEMBLY

TIRE Refer to page 7-33.

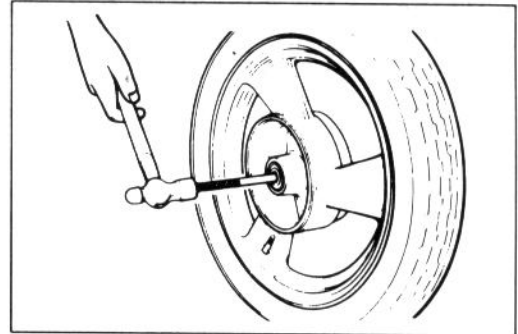
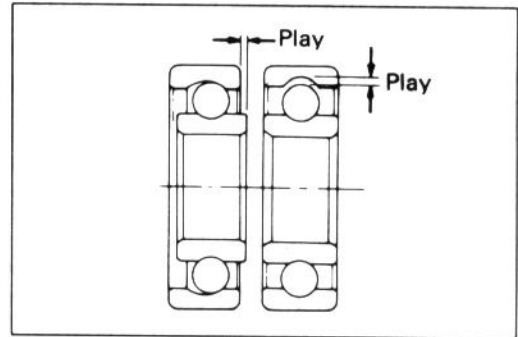
WHEEL AND SPROCKET DRUM BEARINGS

Inspect the play of respective bearings by hand while they are in the wheel and sprocket drum. Rotate the inner race by hand to inspect for abnormal noise and smooth rotation. Replace the bearing if there is anything unusual.

- Drive out the wheel bearings and sprocket drum bearing by using an appropriate tool.

CAUTION:

The removed bearings should be replaced with new ones.



AXLE SHAFT

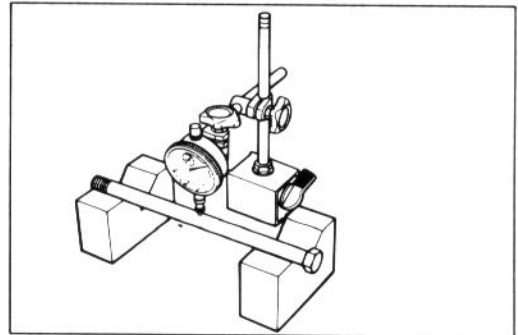
Using a dial gauge, check the axle shaft for runout and replace it if the runout exceeds the limit.

09900-20606 : Dial gauge (1/100)

09900-20701 : Magnetic stand

09900-21304 : V-block set (100 mm)

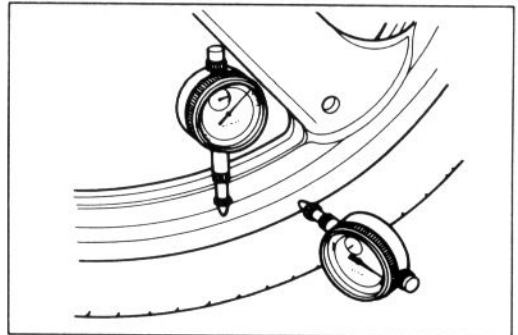
Service limit : 0.25 mm (0.010 in)



WHEEL

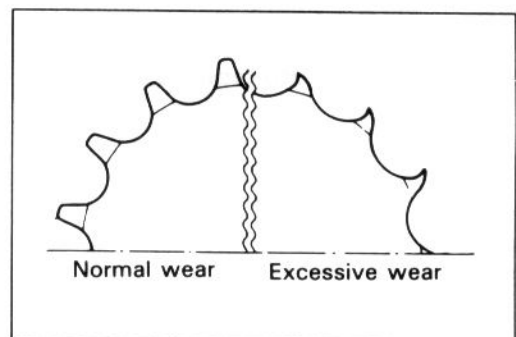
Make sure that the wheel runout checked as shown does not exceed the service limit. An excessive runout is usually due to worn or loose wheel bearings and can be reduced by replacing the bearings. If bearing replacement fails to reduce the runout, replace the wheel.

Service limit (Axial and Radial): 2.0 mm (0.08 in)



SPROCKET

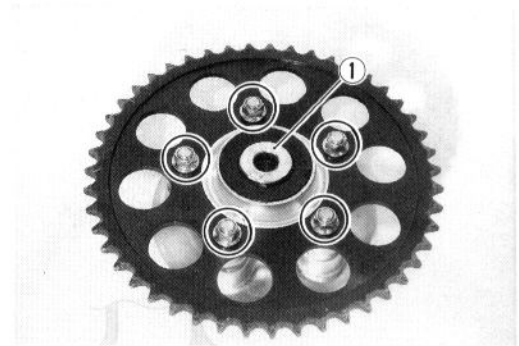
Inspect the sprocket teeth for wear. If they are worn as illustrated, replace the sprocket and drive chain.



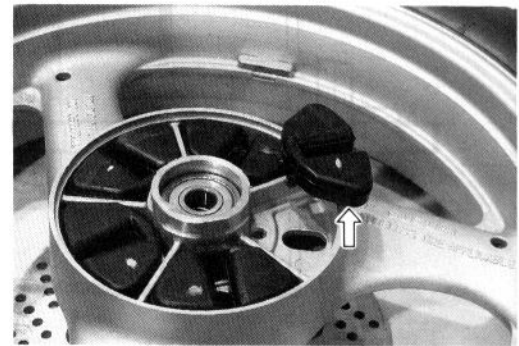
- Remove the rear sprocket by removing the mounting nuts.
- Remove the spacer ①.
Inspect the lip of dust seal for damage.

CAUTION:

The removed dust seal should be replaced with a new one.

**DAMPER**

Inspect the dampers for wear and damage.

**REASSEMBLY AND REMOUNTING**

Reassemble and remount the rear wheel in the reverse order of removal and disassembly. Pay attention to the following points:

WHEEL BEARING

- Apply grease to the bearings before installing.

(For U.S.A. model)

99000-25030 : SUZUKI SUPER GREASE "A"

(For the other models)

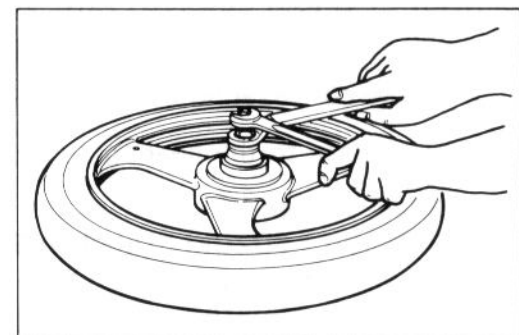
99000-25010 : SUZUKI SUPER GREASE "A"

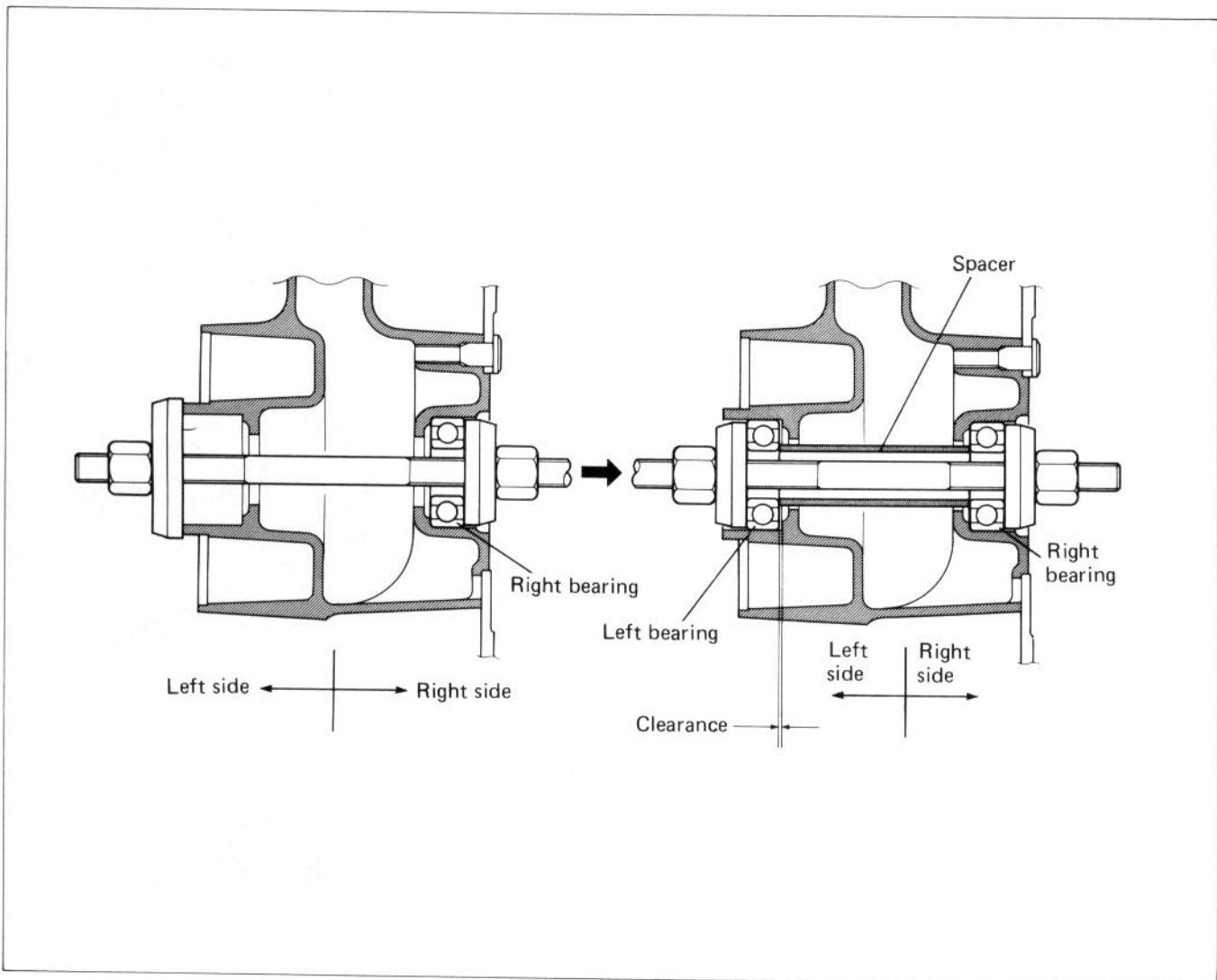
- Install the wheel bearings by using the special tools.

09924-84511: Bearing installer set

NOTE:

First install the right wheel bearing, then install the left wheel bearing. The sealed cover on the bearing is positioned outside. Refer to next page.





SPROCKET DRUM BEARING AND SPROCKET

- Install the bearing by using the special tool.

09913-75520 : Bearing installer

- Apply grease to the bearing and oil seal lip.

(For U.S.A. model)

99000-25030 : SUZUKI SUPER GREASE "A"

(For the other models)

99000-25010 : SUZUKI SUPER GREASE "A"

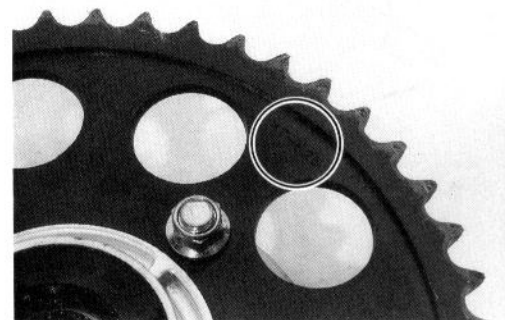
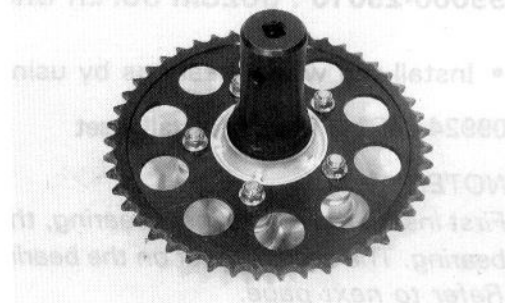
NOTE:

When installing the rear sprocket on its mounting drum, the stamped mark on the sprocket is positioned outside.

- Tighten the sprocket mounting nuts to the specified torque.

Tightening torque : 40 – 60 N·m

(4.0 – 6.0 kg·m, 29.0 – 43.5 lb-ft)

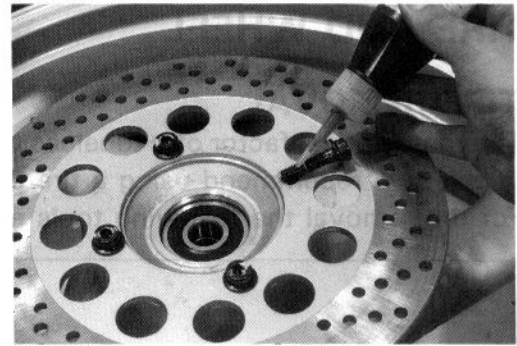


BRAKE DISC

- Make sure that the brake disc is clean and free of any greasy matter.
- Apply THREAD LOCK SUPER "1360" to the disc bolts and tighten them to the specified torque.

99000-32130: THREAD LOCK SUPER "1360"

Tightening torque : 18 – 28 N·m
(1.8 – 2.8 kg·m, 13.0 – 20.0 lb-ft)

**TIGHTENING TORQUE**

Axle nut:

50 – 80 N·m (5.0 – 8.0 kg·m, 36.0 – 58.0 lb-ft) . . . Normal nut with cotter pin

55 – 88 N·m (5.5 – 8.8 kg·m, 40.0 – 63.5 lb-ft) . . . Self-lock nut

Brake caliper mounting bolt:

21 – 31 N·m (2.1 – 3.1 kg·m, 14.5 – 22.5 lb-ft)

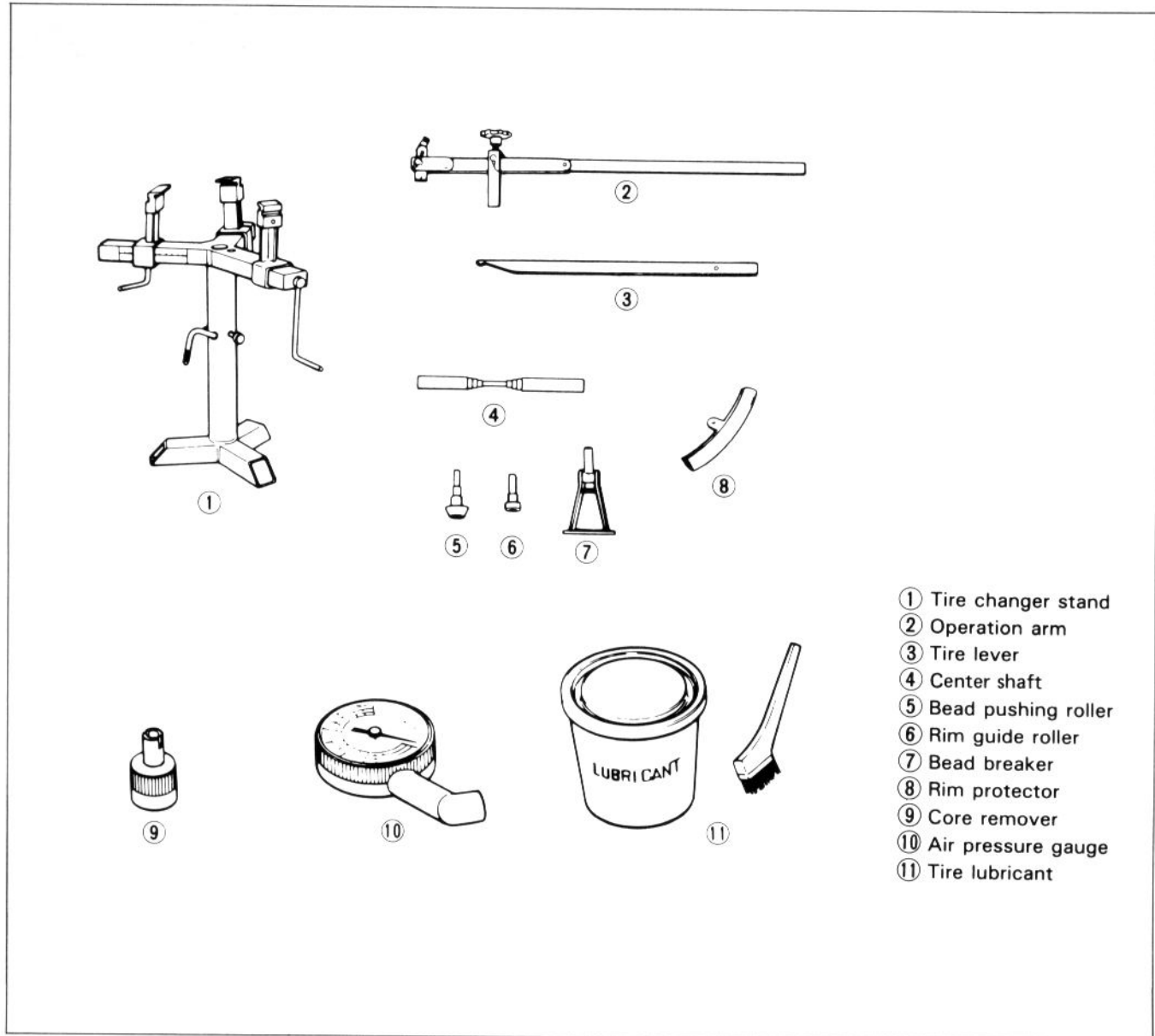
ADJUSTMENT

- Adjust the chain slack after rear wheel installation. (Page 2-11.)

TIRE AND WHEEL

TIRE REMOVAL

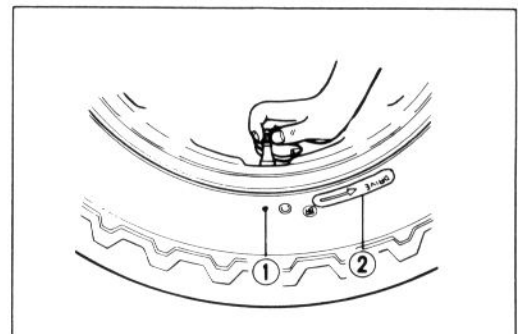
The most critical factor of a tubeless tire is the seal between the wheel rim and the tire bead. Because of this, we recommend using a tire changer which is also more efficient than tire levers. For tire removal the following tools are required.



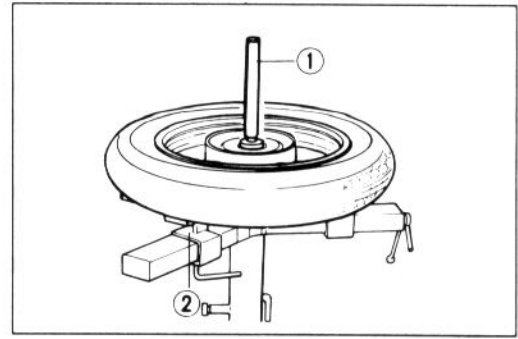
- Remove the valve core from the valve stem, and deflate the tire completely.

NOTE:

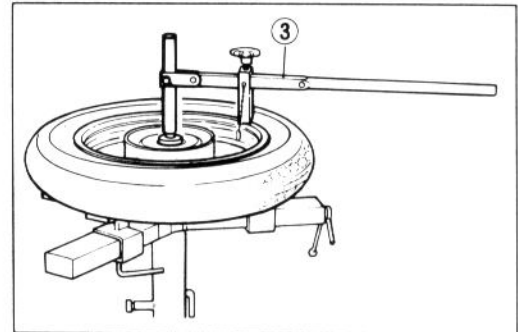
Mark the tire with chalk to note the position ① of the tire on the rim and rotational direction ② of the tire.



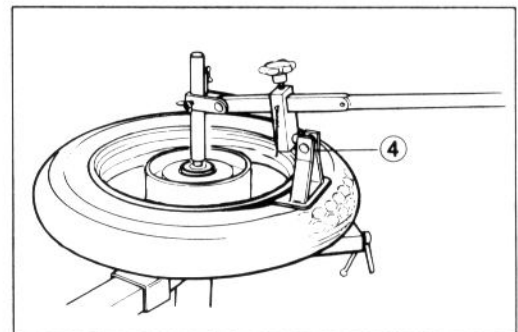
- Place the center shaft ① to the wheel, and fix the wheel with the rim holder ②.



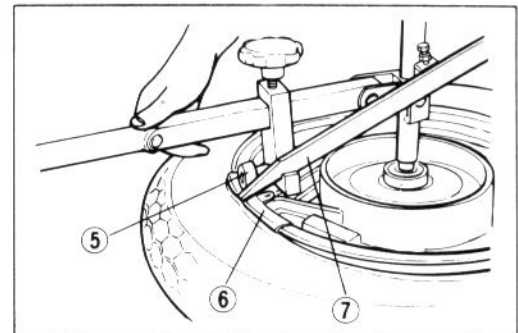
- Attach the operation arm ③ to the center shaft.



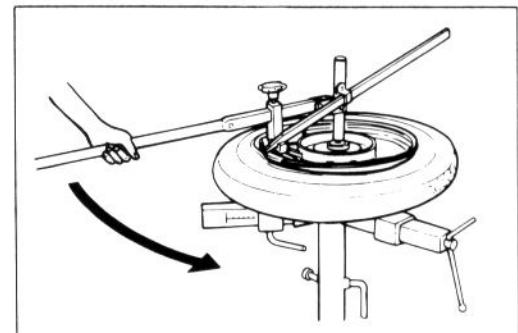
- Attach the bead breaker ④ to the operation arm, and remove the bead from the rim. Turn the wheel over and remove the other bead from the rim.



- Install the rim guide roller ⑤.
- Install the rim protector ⑥, and raise the tire bead with the tire lever ⑦.



- Set the tire lever against the operation arm, and rotate the lever around the rim. Repeat this procedure to remove the other bead from the rim.

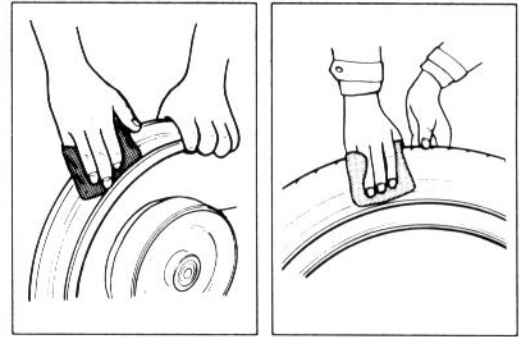


INSPECTION

WHEEL

Wipe off any rubber substance or rust from the wheel, and inspect the wheel rim. If any one of the following items is observed, replace it with a new wheel.

- * A distortion or crack.
- * Any scratches or flaws in the bead seating area.
- * Wheel runout (Axial & Radial) of more than 2.0 mm (0.08 in).



TIRE

Thoroughly inspect the removed tire, and if any one of the following items is observed, do not repair the tire. Replace with a new one.

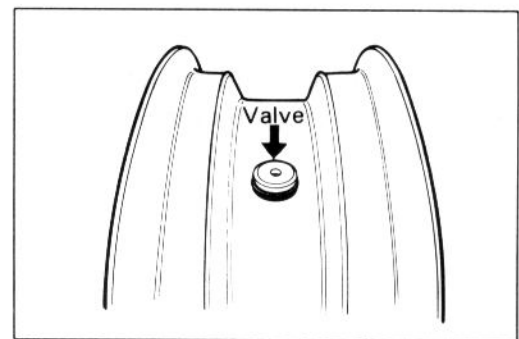
- * A puncture or a split whose total length or diameter exceeds 6.0 mm (0.24 in).
- * A scratch or split at the side wall.
- * Tread depth less than 1.6 mm (0.06 in) in the front tire and less than 2.0 mm (0.08 in) in the rear tire.
- * Ply separation.
- * Tread separation.
- * Tread wear is extraordinarily deformed or distributed around the tire.
- * Scratches at the bead.
- * Cord is cut.
- * Damage from skidding (flat spots).
- * Abnormality in the inner liner.

NOTE:

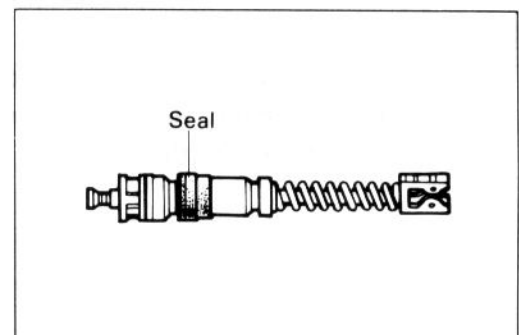
When repairing a flat tire, follow the repair instructions and use only recommended repairing materials.

VALVE INSPECTION

Inspect the valve after the tire is removed from the rim, and replace with a new valve if the seal rubber has any splits or scratches.

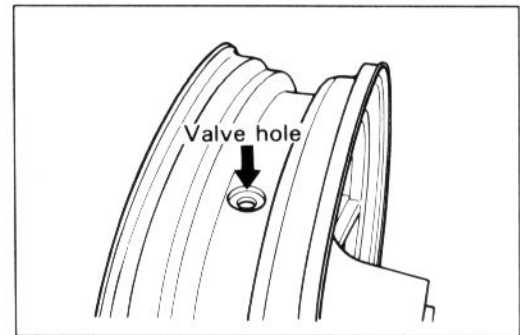


Inspect the removed valve core and replace with the new one if the seal rubber is abnormally deformed or worn.

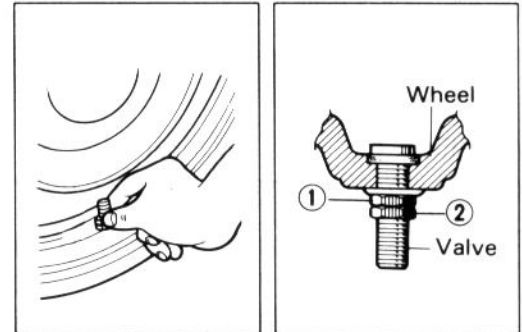


VALVE INSTALLATION

Any dust or rust around the valve hole must be cleaned off. Then install the valve in the rim.

**CAUTION:**

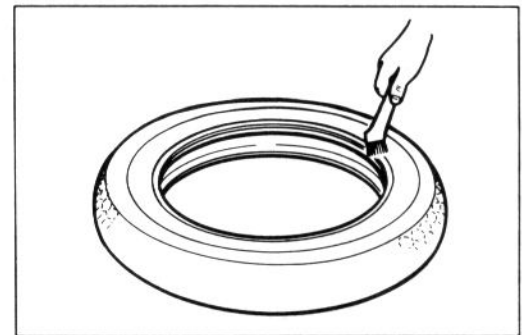
When installing the valve, tighten the nut ① by hand as much as possible. Holding the nut ① under this condition, tighten the lock nut ②. Do not overtighten the nut ① as this may distort the rubber packing and cause an air leak.

**TIRE MOUNTING**

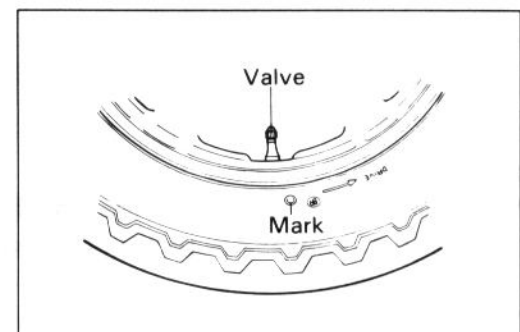
- Apply a special tire lubricant or neutral soapy liquid to the tire bead.

CAUTION:

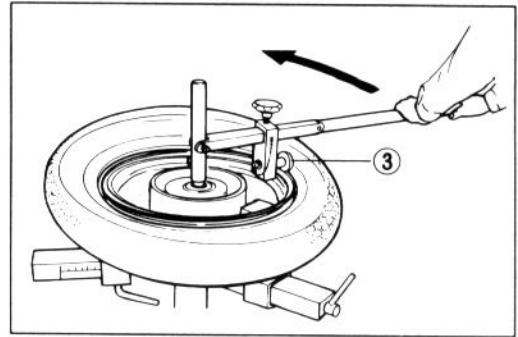
Never apply grease, oil or gasoline to the tire bead.



- When installing the tire, make certain that the directional arrow faces the direction of wheel rotation and align the balancing mark of the tire with the valve as shown.



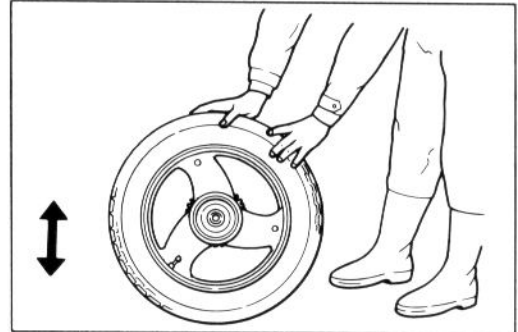
- Set the bead pushing roller ③.
- Rotate the operation arm around the rim to mount the bead completely. Do the bottom bead first, then the upper bead.
- Remove the wheel from the tire changer, and install the valve core in the valve stem.



NOTE:

Before installing the valve core, inspect the core.

- Bounce the tire several times while rotating. This makes the tire bead expand outwards, and thus makes inflation easier.



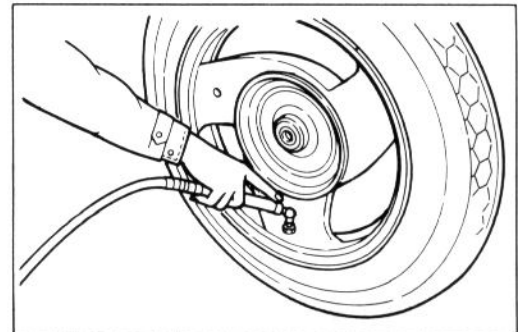
NOTE:

Before inflating, confirm that the balance mark lines up with the valve stem.

- Pump up the tire with air.

WARNING:

Do not inflate the tire to more than 400 kPa (4.0 kg/cm², 56 psi). The tire could burst with sufficient force to cause severe injury. Never stand directly over the tire while inflating it.



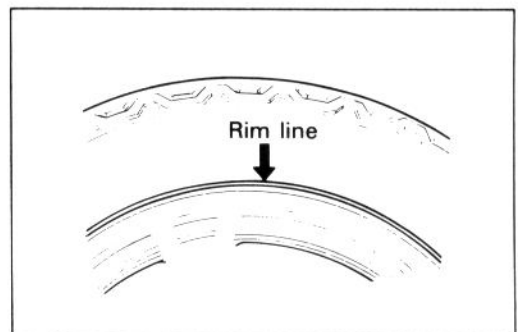
NOTE:

Check the "rim line" cast on the tire side walls. It must be equidistant from the wheel rim all the way around. If the distance between the rim line and wheel rim varies, this indicates that the bead is not properly seated. If this is so, deflate the tire completely, and unseat the bead for both sides. Coat the bead with lubricant, and try again.

- After tire is properly seated to the wheel rim, adjust the air-pressure to the recommended pressure. Correct the wheel balance if necessary.

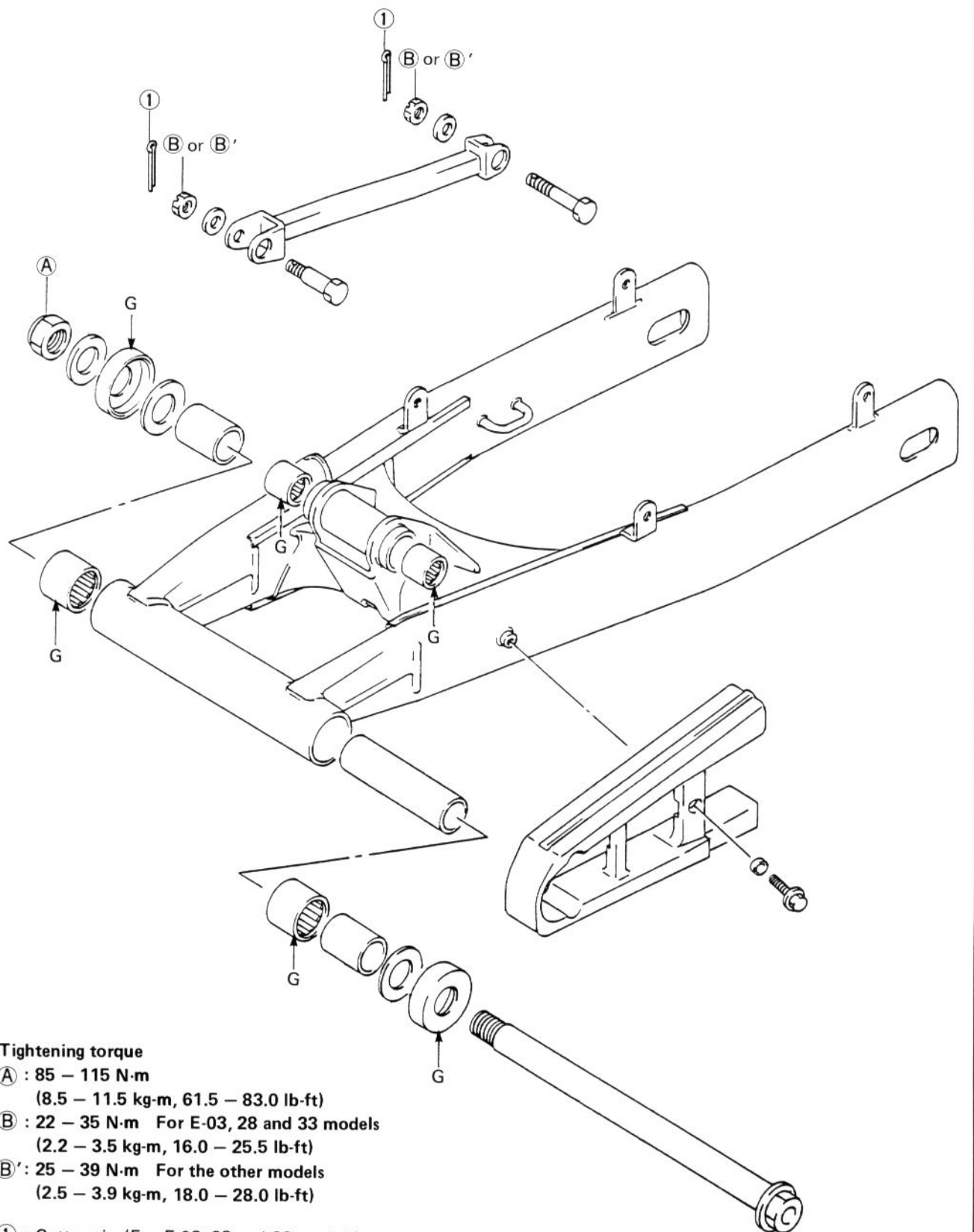
WARNING:

- * Do not run a repaired tire more than 50 km/h (30 mph) within 24 hours after tire repairing, since the patch may not be completely cured.
- * Do not exceed 130 km/h (80 mph) with a repaired tire.



REAR SUSPENSION

SWINGARM



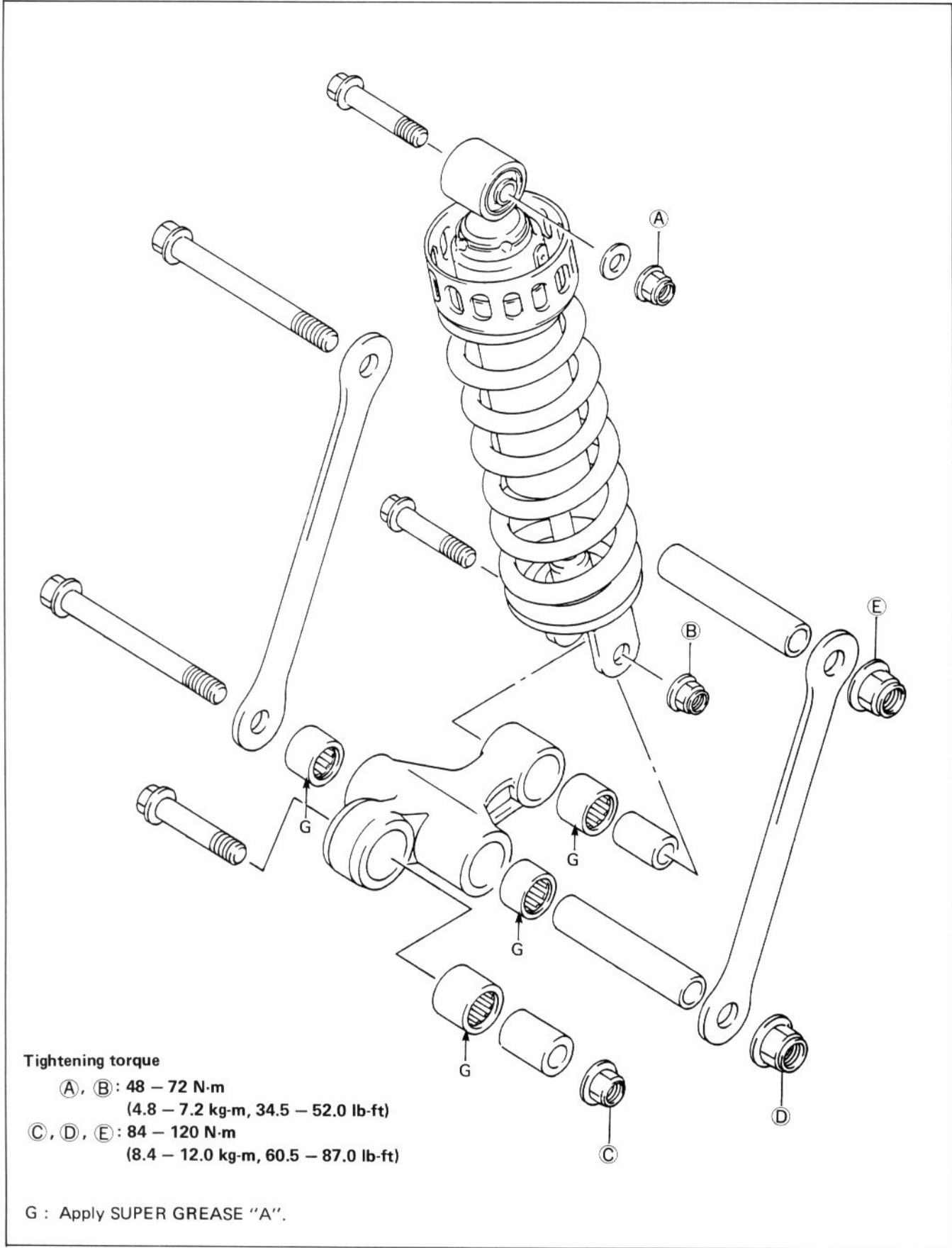
Tightening torque

- A** : 85 – 115 N·m
 (8.5 – 11.5 kg-m, 61.5 – 83.0 lb-ft)
- B** : 22 – 35 N·m For E-03, 28 and 33 models
 (2.2 – 3.5 kg-m, 16.0 – 25.5 lb-ft)
- B'** : 25 – 39 N·m For the other models
 (2.5 – 3.9 kg-m, 18.0 – 28.0 lb-ft)

① : Cotter pin (For E-03, 28 and 33 models)

G : Apply SUPER GREASE "A".

SHOCK ABSORBER AND CUSHION LEVER



Tightening torque

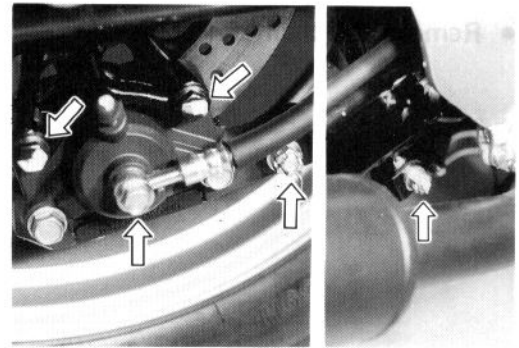
Ⓐ, Ⓑ: 48 – 72 N·m
(4.8 – 7.2 kg·m, 34.5 – 52.0 lb-ft)

Ⓒ, Ⓓ, Ⓔ: 84 – 120 N·m
(8.4 – 12.0 kg·m, 60.5 – 87.0 lb-ft)

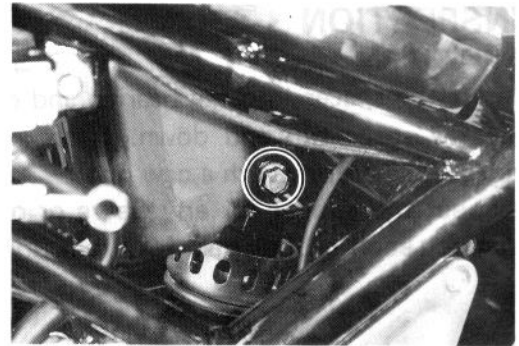
G : Apply SUPER GREASE "A".

REMOVAL

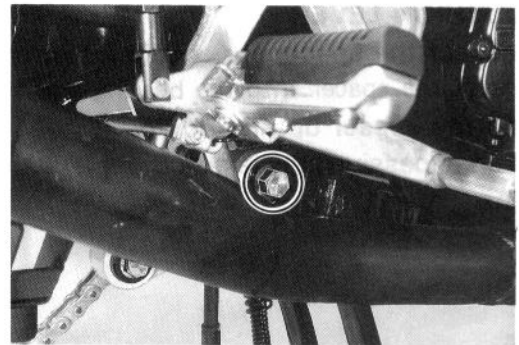
- Remove the brake hose union bolt. (Refer to page 7-22.)
- Remove the brake caliper and rear wheel. (Refer to page 7-27.)
- Remove the cotter pins. (For E-03, 28 and 33 models)
- Remove the torque link mounting bolts and nuts.



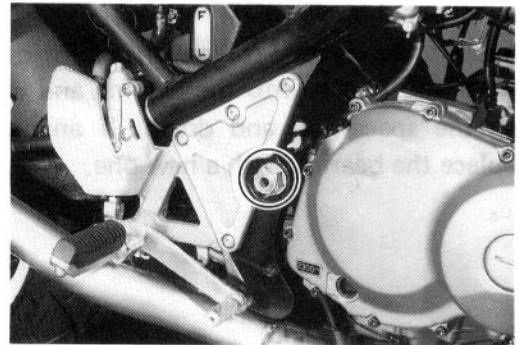
- Remove the shock absorber upper mounting bolt.



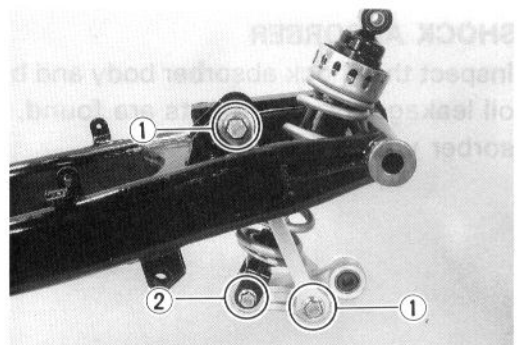
- Remove the cushion lever mounting bolt.



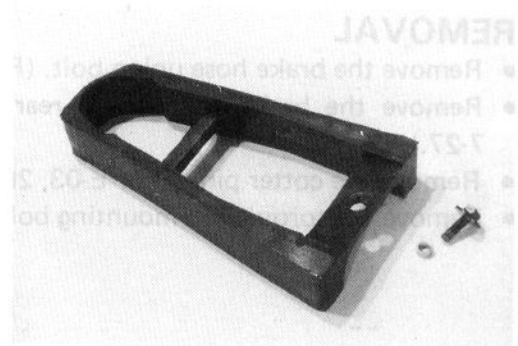
- Remove the swingarm pivot shaft.
- Remove the rear suspension assembly.



- Remove the drive chain cover/rear fender.
- Remove the cushion lever/rod bolts ①.
- Remove the shock absorber lower mounting bolt ②.



- Remove the chain buffer.

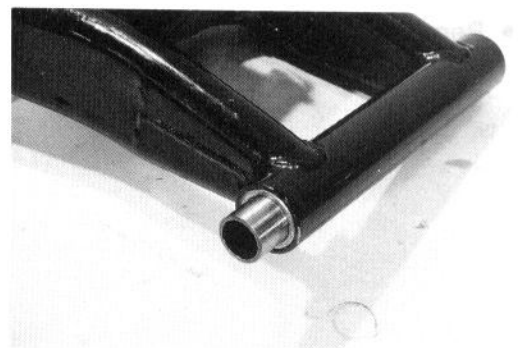


INSPECTION SWINGARM

Insert the spacer into the bearing and check the play by moving the spacer up and down. If an excessive play is noted, replace the bearing with a new one.

Inspect the spacer for any flaws or other damage.

Inspect each rubber part for wear and damage.

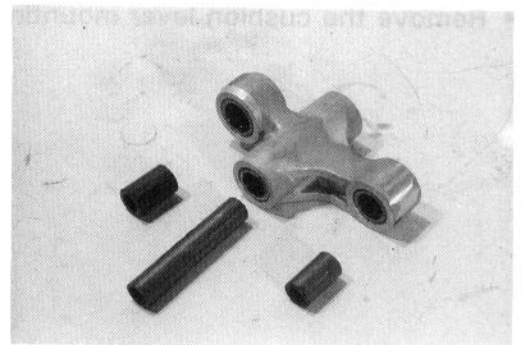


CUSHION LEVER

Inspect the spacer for any flaws or other damage.

Insert the spacer into the bearing and check the play by moving the spacer up and down.

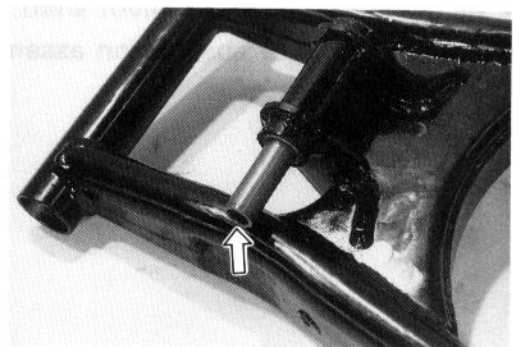
If an excessive play is noted, replace the bearing with a new one.



CUSHION LEVER ROD

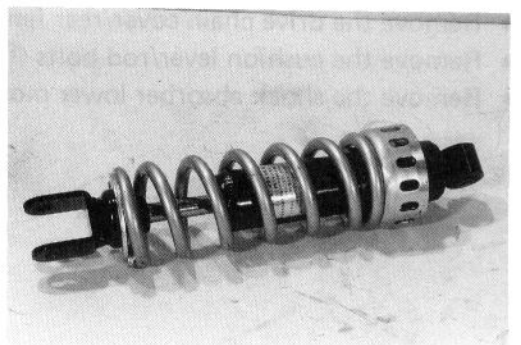
Inspect the spacer for any flaws or other damage.

Insert the spacer into the bearing and check the play by moving the spacer up and down. If an excessive play is noted, replace the bearing with a new one.



SHOCK ABSORBER

Inspect the shock absorber body and bushing for damage and oil leakage. If any defects are found, replace the shock absorber with a new one.



SWINGARM PIVOT SHAFT

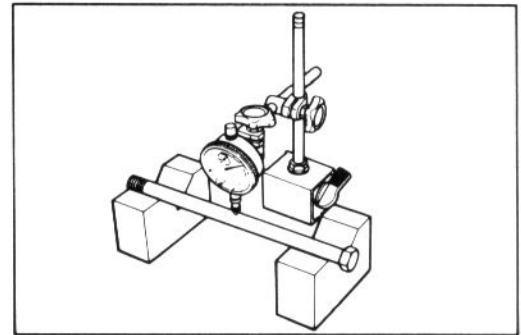
Using a dial gauge, check the pivot shaft runout and replace it if the runout exceeds the limit.

09900-20606 : Dial gauge (1/100)

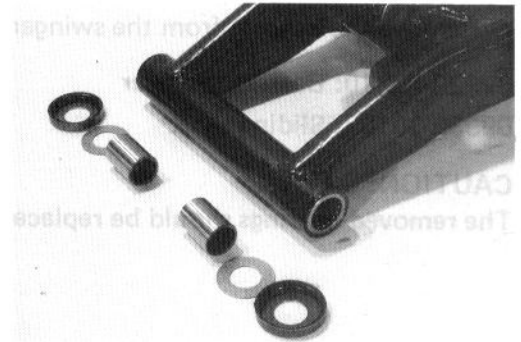
09900-20701 : Magnetic stand

09900-21304 : V-block set (100 mm)

Service limit : 0.3 mm (0.01 in)

**DISASSEMBLY****SWINGARM**

- Remove the dust seals, washers and spacers from the swingarm pivot.

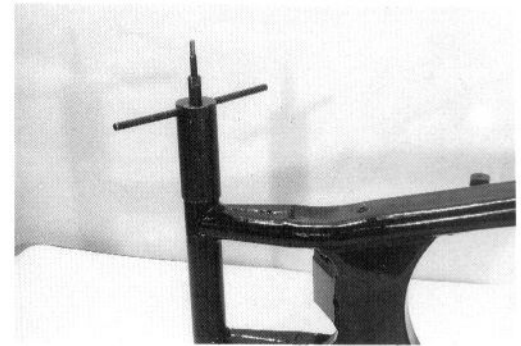


- Remove the swingarm bearings by using the special tool.

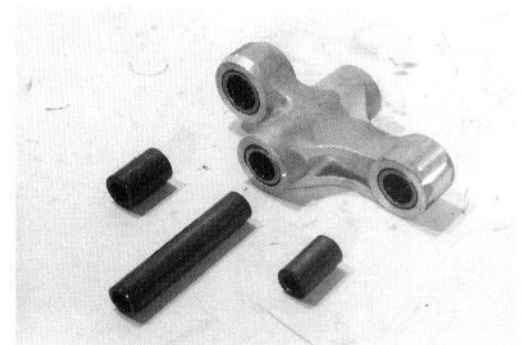
09941-44910: Swingarm bearing remover

CAUTION:

The removed bearings should be replaced with new ones.

**CUSHION LEVER**

- Remove the spacers.



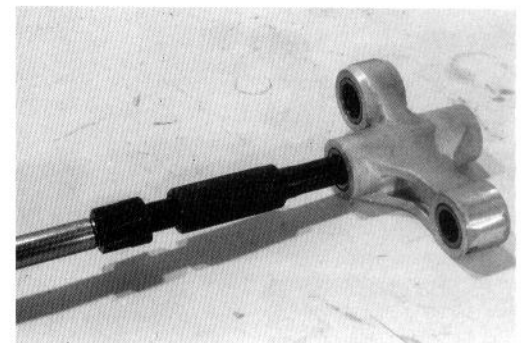
- Remove the bearings by using the special tool.

09923-73210: Bearing remover

09930-30102: Sliding shaft

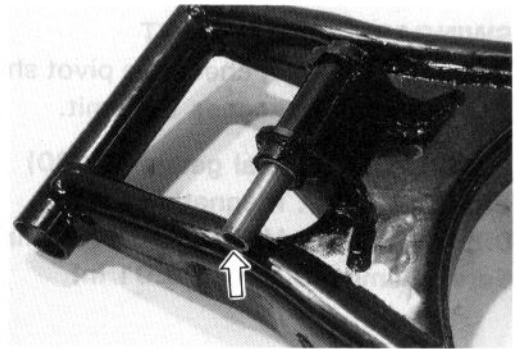
CAUTION:

The removed bearings should be replaced with new ones.



CUSHION LEVER ROD

- Remove the spacer from the swingarm.



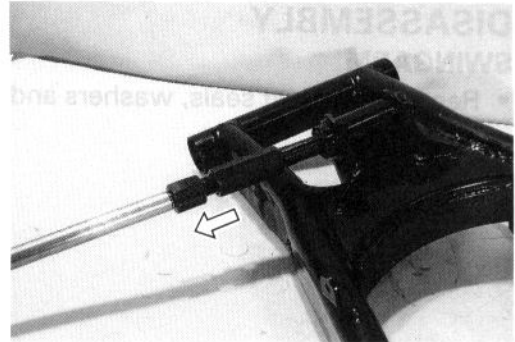
- Remove the bearing from the swingarm.

09923-73210: Bearing remover

09930-30102: Sliding shaft

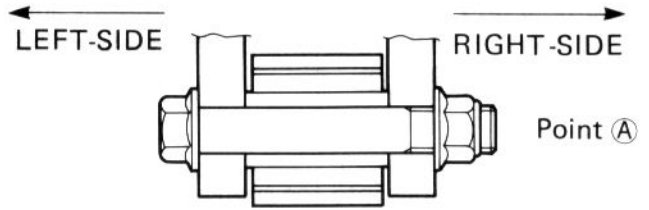
CAUTION:

The removed bearings should be replaced with new ones.

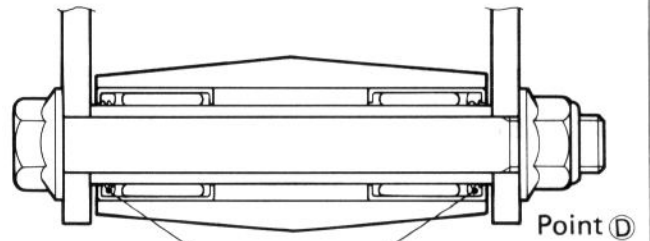
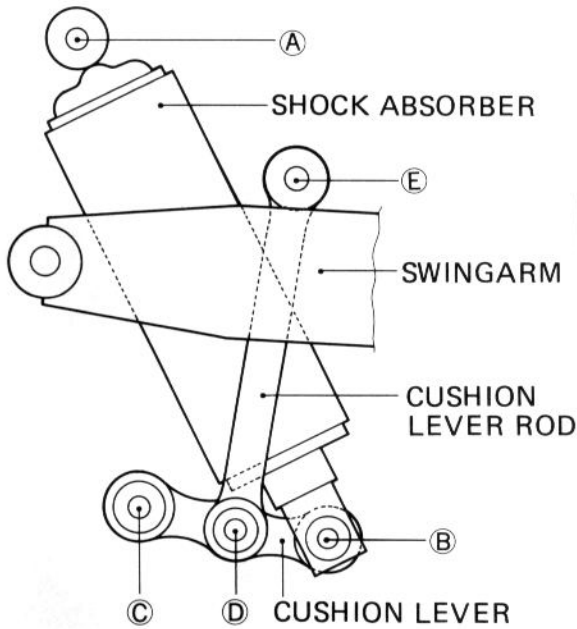
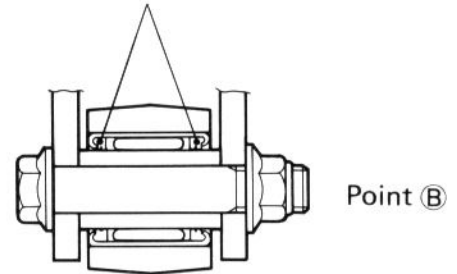


REASSEMBLY INFORMATION

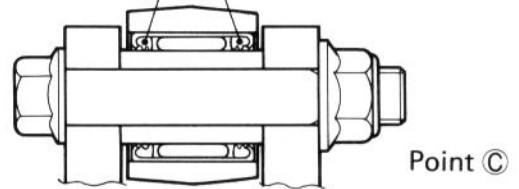
Tightening torque			
ITEM	N-m	kg-m	lb-ft
Ⓐ	48 - 72	4.8 - 7.2	34.5 - 52.0
Ⓑ			
Ⓒ	84 - 120	8.4 - 12.0	60.5 - 87.0
Ⓓ			
Ⓔ			



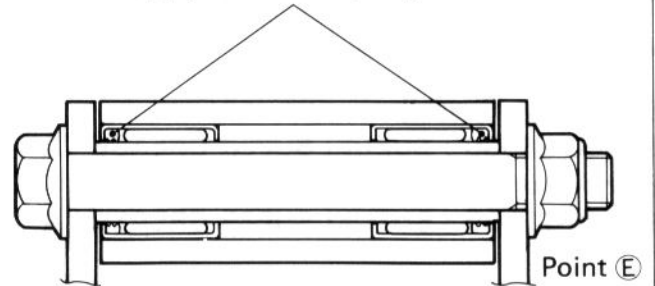
Apply SUZUKI super grease "A".



Apply SUZUKI super grease "A".



Apply SUZUKI super grease "A".



REASSEMBLY AND REMOUNTING

Reassemble and remount the swingarm, rear shock absorber, rear cushion lever rods and cushion lever. Pay attention to the following points:

SWINGARM

- Press-fit the bearings into the swingarm pivot.

09941-34513 : Steering outer race installer

NOTE:

When installing the bearings, punch-marked side of bearing faces outside.

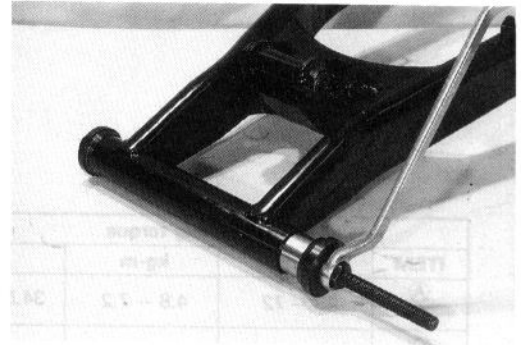
- Apply grease to the spacers and dust seals when installing them.

(For U.S.A. model)

99000-25030 : SUZUKI SUPER GREASE "A"

(For the other models)

99000-25010 : SUZUKI SUPER GREASE "A"



CUSHION LEVER

- Press-fit the cushion lever bearings into the cushion lever.

09941-34513: Steering outer race installer

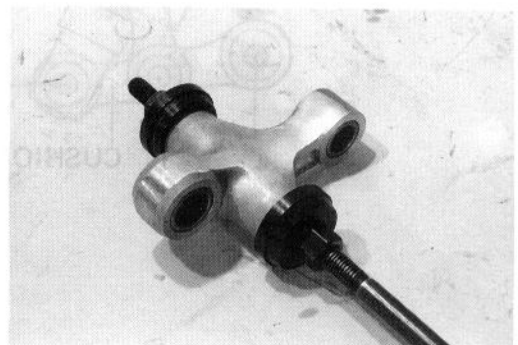
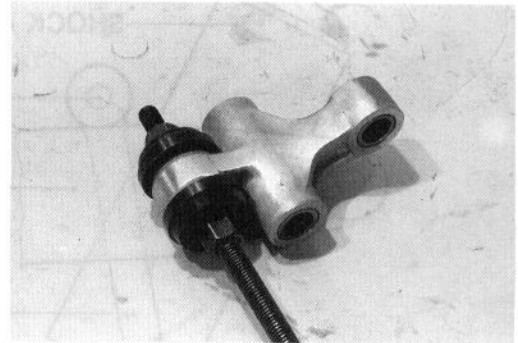
- Apply grease to the bearings.

(For U.S.A. model)

99000-25030 : SUZUKI SUPER GREASE "A"

(For the other models)

99000-25010 : SUZUKI SUPER GREASE "A"



CUSHION LEVER ROD

- Press-fit the cushion lever rod bearings into the cushion lever rod pivot.

09941-34513: Steering outer race installer

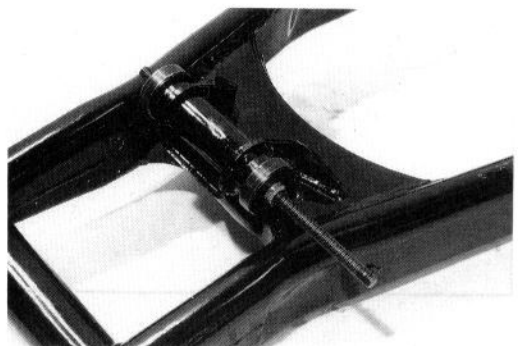
- Apply grease to the bearings.

(For U.S.A. model)

99000-25030 : SUZUKI SUPER GREASE "A"

(For the other models)

99000-25010 : SUZUKI SUPER GREASE "A"



TIGHTENING TORQUE

- Install the rear suspension and tighten each nut to the specified torque. (Refer to page 7-44.)

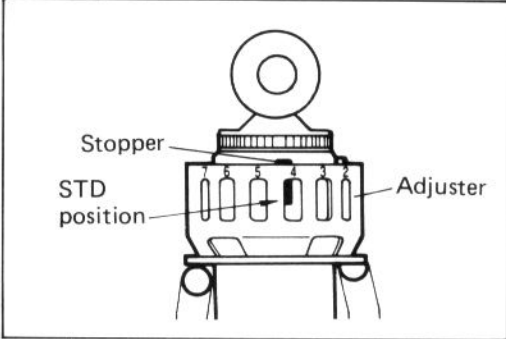
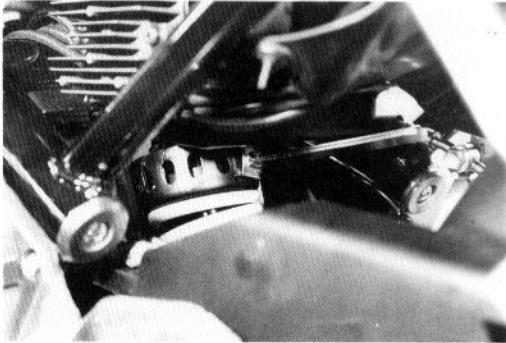
FINAL INSPECTION AND AJDUSTMENT

After installing the rear suspension and rear wheel, the following adjustments are required before driving motorcycle.

- * Drive chain Page 2-11
- * Rear brake Page 2-14
- * Tire pressure Page 2-16
- * Shock absorber This page

SHOCK ABSORBER SPRING PRE-LOAD

- * Position "1" provides the softest spring pre-load.
- * Position "7" provides the stiffest spring pre-load.
(Factory setting : 4/7)



SERVICING INFORMATION

CONTENTS

TROUBLESHOOTING	8- 1
WIRING DIAGRAM	8- 9
WIRE HARNESS, CABLE AND HOSE ROUTING	8-12
SPECIAL TOOLS	8-22
TIGHTENING TORQUE	8-25
SERVICE DATA	8-28

TROUBLESHOOTING

ENGINE

Complaint	Symptom and possible causes	Remedy
<p>Engine will not start, or is hard to start.</p>	<p>Compression too low</p> <ol style="list-style-type: none"> 1. Valve clearance out of adjustment. 2. Worn valve guides or poor seating of valves. 3. Valves mistiming. 4. Piston rings excessively worn. 5. Worn-down cylinder bores. 6. Starter motor cranks but too slowly. 7. Poor seating of spark plugs. <p>Plugs not sparking</p> <ol style="list-style-type: none"> 1. Fouled spark plugs. 2. Wet spark plugs. 3. Defective ignition coil. 4. Open or short in high-tension cords. 5. Defective signal generator or ignitor unit. <p>No fuel reaching the carburetors</p> <ol style="list-style-type: none"> 1. Clogged fuel tank vent hose. 2. Clogged or defective fuel/cock. 3. Defective carburetor float valve. 4. Clogged fuel hose or fuel filter. 	<p>Adjust. Repair, or replace. Adjust. Replace. Replace, or rebore. Consult "electrical complaints" Retighten.</p> <p>Clean. Clean and dry. Replace. Replace. Replace.</p> <p>Clean or replace. Clean or replace. Replace. Clean or replace.</p>
<p>Engine stalls easily.</p>	<ol style="list-style-type: none"> 1. Fouled spark plugs. 2. Defective signal generator or ignitor unit. 3. Clogged fuel hose. 4. Clogged jets in carburetors. 5. Valve clearance out of adjustment. 	<p>Clean. Replace. Clean. Clean. Adjust.</p>
<p>Noisy engine.</p>	<p>Excessive valve chatter</p> <ol style="list-style-type: none"> 1. Valve clearance too large. 2. Weakened or broken valve springs. 3. Worn down rocker arm or rocker arm shaft. 4. Camshaft journal worn and burnt. <p>Noise appears to come from piston</p> <ol style="list-style-type: none"> 1. Pistons or cylinders worn down. 2. Combustion chambers fouled with carbon. 3. Piston pins or piston pin bore worn. 4. Piston rings or ring grooves worn. <p>Noise seems to come from timing chain</p> <ol style="list-style-type: none"> 1. Stretched chain. 2. Worn sprockets. 3. Tension adjuster not working. <p>Noise seems to come from clutch</p> <ol style="list-style-type: none"> 1. Worn splines of countershaft or hub. 2. Worn teeth of clutch plates. 3. Distorted clutch plates, driven and drive. 4. Worn clutch release bearing. 5. Clutch dampers weakened. 	<p>Adjust. Replace. Replace. Replace.</p> <p>Replace. Clean. Replace. Replace.</p> <p>Replace. Replace. Repair, or replace.</p> <p>Replace. Replace. Replace. Replace. Replace the primary driven gear.</p>

Complaint	Symptom and possible causes	Remedy
<p>Noisy engine.</p>	<p>Noise seems to come from crankshaft</p> <ol style="list-style-type: none"> 1. Rattling bearings due to wear. 2. Big-end bearings worn and burnt. 3. Journal bearings worn and burnt. 4. Thrust clearance too large. <p>Noise seems to come from transmission</p> <ol style="list-style-type: none"> 1. Gears worn or rubbing. 2. Badly worn splines. 3. Primary gears worn or rubbing. 4. Badly worn bearings. <p>Noise seems to come from water pump</p> <ol style="list-style-type: none"> 1. Too much play on pump shaft bearing. 2. Worn or damaged mechanical seal. 3. Impeller touches pump case. 	<p>Replace. Replace. Replace. Replace thrust bearing.</p> <p>Replace. Replace. Replace. Replace.</p> <p>Replace. Replace. Replace.</p>
<p>Slipping clutch.</p>	<ol style="list-style-type: none"> 1. Clutch control out of adjustment or loss of play. 2. Weakened clutch springs. 3. Worn or distorted pressure plate. 4. Distorted clutch plates, driven and drive. 	<p>Adjust. Replace. Replace. Replace.</p>
<p>Dragging clutch.</p>	<ol style="list-style-type: none"> 1. Clutch control out of adjustment or too much play. 2. Some clutch springs weakened while others are not. 3. Distorted pressure plate or clutch plate. 	<p>Adjust. Replace. Replace.</p>
<p>Transmission will not shift.</p>	<ol style="list-style-type: none"> 1. Broken gearshift cam. 2. Distorted gearshift forks. 3. Worn gearshift pawl. 	<p>Replace. Replace. Replace.</p>
<p>Transmission will not shift back.</p>	<ol style="list-style-type: none"> 1. Broken return spring on shift shaft. 2. Shift shaft is rubbing or sticky. 3. Distorted or worn gearshift forks. 	<p>Replace. Repair. Replace.</p>
<p>Transmission jumps out of gear.</p>	<ol style="list-style-type: none"> 1. Worn shifting gears on driveshaft or countershaft. 2. Distorted or worn gearshift forks. 3. Weakened stopper spring on gearshift stopper. 4. Worn gearshift pawl. 	<p>Replace. Replace. Replace. Replace.</p>
<p>Engine idles poorly.</p>	<ol style="list-style-type: none"> 1. Valve clearance out of adjustment. 2. Poor seating of valves. 3. Defective valve guides. 4. Worn rocker arms or arm shafts. 5. Spark plug gaps too wide. 6. Defective ignition coil. 7. Defective signal generator or ignitor unit. 8. Float-chamber fuel level out of adjustment in carburetors. 9. Clogged jets or imbalance of carburetors. 	<p>Adjust. Replace or repair. Replace. Replace. Adjust or replace. Replace. Replace. Adjust. Clean or adjust.</p>
<p>Engine runs poorly in high speed range.</p>	<ol style="list-style-type: none"> 1. Valve springs weakened. 2. Worn cams or rocker arms. 3. Valve timing out of adjustment. 4. Spark plug gaps too narrow. 5. Ignition not advanced sufficiently due to poorly working timing advance circuit. 6. Defective ignition coil. 7. Defective signal generator or ignitor unit. 8. Float-chamber fuel level too low. 9. Clogged air cleaner element. 10. Clogged fuel hose, resulting in inadequate fuel supply to carburetors. 	<p>Replace. Replace. Adjust. Adjust. Replace ignitor unit.</p> <p>Replace. Replace. Adjust. Clean. Clean, and prime.</p>

8-3 SERVICING INFORMATION

Complaint	Symptom and possible causes	Remedy
Dirty or heavy exhaust smoke.	<ol style="list-style-type: none"> 1. Too much engine oil in the engine. 2. Worn piston rings or cylinders. 3. Worn valve guides. 4. Cylinder walls scored or scuffed. 5. Worn valves stems. 6. Defective stem seal. 7. Worn oil ring side rails. 	Check with level window, drain out excess oil Replace. Replace. Rebore or replace. Replace. Replace. Replace.
Engine lacks power.	<ol style="list-style-type: none"> 1. Loss of valve clearance. 2. Weakened valve springs. 3. Valve timing out of adjustment. 4. Worn piston rings or cylinders. 5. Poor seating of valves. 6. Fouled spark plug. 7. Spark plug gaps incorrect. 8. Clogged jets in carburetors. 9. Float-chamber fuel level out of adjustment. 10. Clogged air cleaner element. 11. Carburetor balancing screw loose. 12. Sucking air from intake pipe. 13. Too much engine oil. 	Adjust. Replace. Adjust. Replace. Repair. Clean or replace. Adjust or replace. Clean. Adjust. Clean. Retighten. Retighten or replace. Drain out excess oil.
Engine overheats.	<ol style="list-style-type: none"> 1. Heavy carbon deposit on piston crowns. 2. Not enough oil in the engine. 3. Defective oil pump or clogged oil circuit. 4. Fuel level too low in float chambers. 5. Sucking air from intake pipes. 6. Use incorrect engine oil. 7. Defective cooling system. 	Clean. Add oil. Replace or clean. Adjust. Retighten or replace. Change. See radiator section.

RADIATOR

Complaint	Symptom and possible causes	Remedy
Engine overheats.	<ol style="list-style-type: none"> 1. Not enough cooling water. 2. Radiator core is clogged with dirt or trashes. 3. Erratic thermostat, stuck in closed position. 4. Faulty cooling fan. 5. Defective thermo-switch. 6. Clogged water passage. 7. Air trapped in the cooling circuit. 8. Defective water pump. 9. Use incorrect coolant. 	Add coolant. Clean. Replace. Repair or replace. Replace. Clean. Bleed out air. Replace. Replace.
Engine overcools.	<ol style="list-style-type: none"> 1. Erratic thermostat, stuck in full-open position. 2. Defective thermo-switch. 3. Extremely cold weather. 	Replace. Replace. Put on the radiator cover.

CARBURETOR

Complaint	Symptom and possible causes	Remedy
Trouble with starting.	<ol style="list-style-type: none"> 1. Starter jet is clogged. 2. Starter pipe is clogged. 3. Air leaking from a joint between starter body and carburetor. 4. Air leaking from carburetor's joint or vacuum gauge joint. 5. Starter plunger is not operating properly. 	<p>Clean. Clean. Check starter body and carburetor for tightness, adjust and replace gasket. Check and adjust. Check and adjust.</p>
Idling or low-speed trouble.	<ol style="list-style-type: none"> 1. Pilot jet, pilot air jet are clogged or loose. 2. Air leaking from carburetor's joint, vacuum gauge joint, or starter. 3. Pilot outlet or bypass is clogged. 4. Starter plunger is not fully closed. 	<p>Check and clean. Check and adjust. Check and clean. Check and adjust.</p>
Medium-or high speed trouble.	<ol style="list-style-type: none"> 1. Main jet or main air jet is clogged. 2. Needle jet is clogged. 3. Throttle valve is not operating properly. 4. Fuel filter is clogged. 	<p>Check and clean. Check and clean. Check throttle valve for operation. Check and clean.</p>
Overflow and fuel level fluctuations.	<ol style="list-style-type: none"> 1. Needle valve is worn or damaged. 2. Spring in needle valve is broken. 3. Float is not working properly. 4. Foreign matter has adhered to needle valve. 5. Fuel level is too high or low. 	<p>Replace. Replace. Check and adjust. Clean. Adjust float height.</p>

ELECTRICAL

Complaint	Symptom and possible causes	Remedy
No sparking or poor sparking.	<ol style="list-style-type: none"> 1. Defective ignition coil. 2. Defective spark plugs. 3. Defective signal generator or ignitor unit. 	Replace. Replace. Replace.
Spark plugs soon become fouled with carbon.	<ol style="list-style-type: none"> 1. Mixture too rich. 2. Idling speed set to high. 3. Incorrect gasoline. 4. Dirty element in air cleaner. 5. Spark plugs too cold. 	Adjust carburetors. Adjust carburetors. Change. Clean. Replace with hot type plugs.
Spark plugs become fouled too soon.	<ol style="list-style-type: none"> 1. Worn piston rings. 2. Piston or cylinders worn. 3. Excessive clearance of valve stems in valve guides. 4. Worn stem oil seal. 	Replace. Replace. Replace. Replace.
Spark plug electrodes overheat or burn.	<ol style="list-style-type: none"> 1. Spark plugs too hot. 2. The engine overheats. 3. Spark plugs loose. 4. Mixture too lean. 	Replace with cold type plugs. Tune up. Retighten. Adjust carburetors.
Generator does not charge.	<ol style="list-style-type: none"> 1. Open or short lead wires, or loose lead connections. 2. Shorted, grounded or open generator coils. 3. Shorted or panctured regulator/rectifier. 	Repair or replace or retighten. Replace. Replace.
Generator does charge, but charging rate is below the specification.	<ol style="list-style-type: none"> 1. Lead wires tend to get shorted or open-circuited or loosely connected at terminals. 2. Grounded or open-circuited stator coils of generator. 3. Defective regulator/rectifier. 4. Not enough electrolyte in the battery. 5. Defective cell plates in the battery. 	Repair, or retighten. Replace. Replace. Add distilled water to the upper level. Replace the battery.
Generator overcharges.	<ol style="list-style-type: none"> 1. Internal short-circuit in the battery. 2. Resistor element in the regulator/rectifier damaged or defective. 3. Regulator/rectifier poorly grounded. 	Replace the battery. Replace. Clean and tighten ground connection.
Unstable charging.	<ol style="list-style-type: none"> 1. Lead wire insulation frayed due to vibration, resulting in intermittent shorting. 2. Generator internally shorted. 3. Defective regulator/rectifier. 	Repair, or replace. Replace. Replace.
Starter button is not effective.	<ol style="list-style-type: none"> 1. Battery run down. 2. Defective switch contacts. 3. Brushes not seating properly on commutator in starter motor. 4. Defective starter relay/starter interlock switch. 	Repair, or replace. Replace. Repair, or replace. Replace.

BATTERY

Complaint	Symptom and possible causes	Remedy
"Sulfation", acidic white powdery substance or spots on surfaces of cell plates.	<ol style="list-style-type: none"> 1. Battery case is cracked. 2. Battery has been left in a run-down condition for a long time. 	<p>Replace the battery.</p> <p>Replace the battery.</p>
Battery runs down quickly.	<ol style="list-style-type: none"> 1. The charging system is not correct. 2. Cell plates have lost much of their active material as a result of overcharging. 3. A short-circuit condition exists within the battery. 4. Battery voltage is too low. 5. Battery is too old. 	<p>Check the generator, regulator/rectifier and circuit connections, and make necessary adjustments to obtain specified charging operation.</p> <p>Replace the battery, and correct the charging system.</p> <p>Replace the battery.</p> <p>Recharge the battery fully.</p> <p>Replace the battery.</p>
Battery "sulfation".	<ol style="list-style-type: none"> 1. Charging rate too low or too high. (When not in use batteries should be recharged at least once a month to avoid sulfation.) 2. The battery left unused for too long in cold climate. 	<p>Replace the battery.</p> <p>Replace the battery, if badly sulfated.</p>
Battery discharges too rapidly.	Dirty container top and sides.	Clean.

CHASSIS

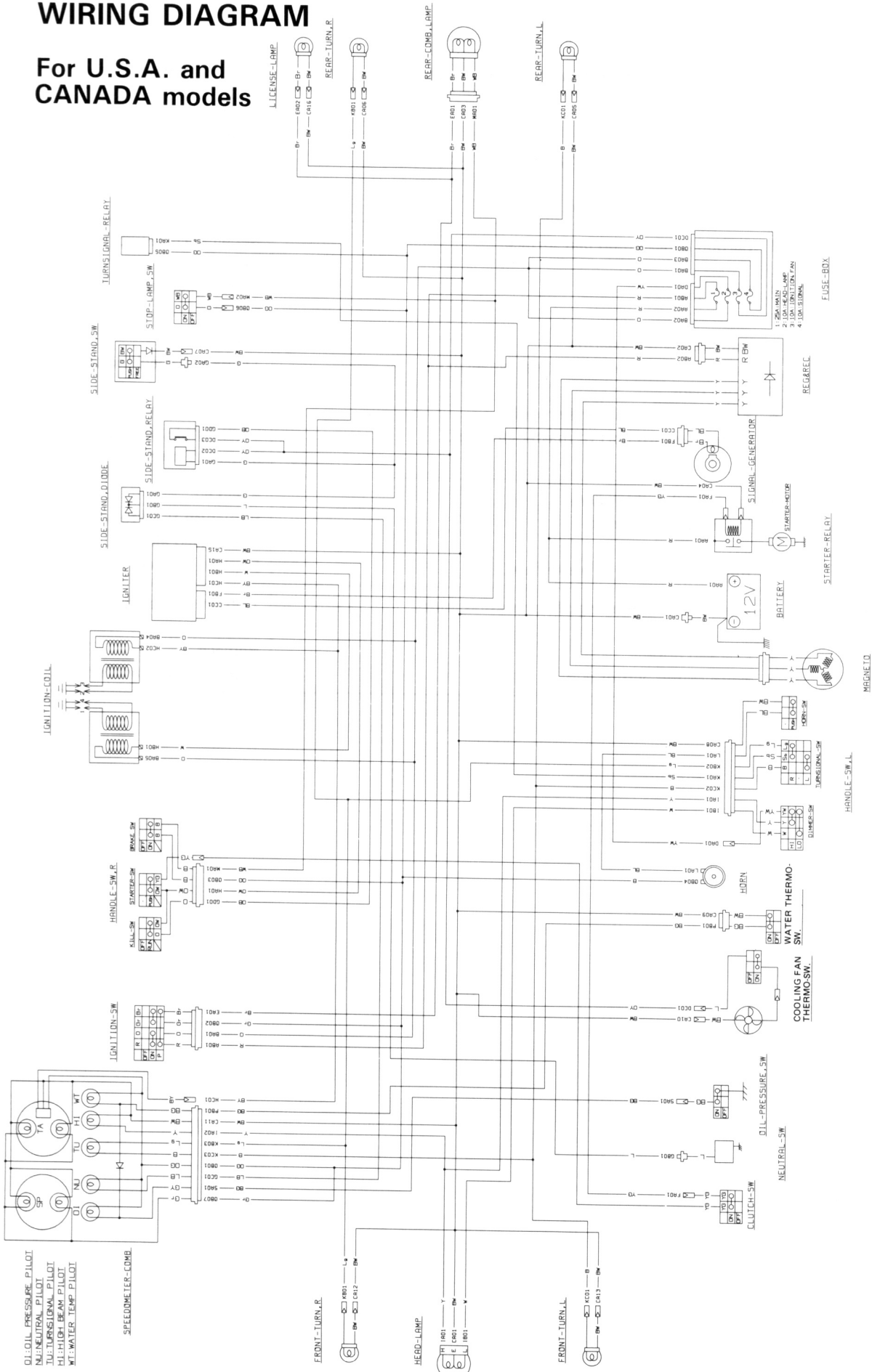
Complaint	Symptom and possible causes	Remedy
Heavy steering.	<ol style="list-style-type: none"> 1. Steering stem nut overtightened. 2. Broken bearing in steering stem. 3. Distorted steering stem. 4. Not enough pressure in tires. 	Adjust. Replace. Replace. Adjust.
Wobbly handlebars.	<ol style="list-style-type: none"> 1. Loss of balance between right and left front forks. 2. Distorted front fork. 3. Distorted front axle or crooked tire. 	Replace. Repair, or replace. Replace.
Wobbly front wheel.	<ol style="list-style-type: none"> 1. Distorted wheel rim. 2. Worn front wheel bearings. 3. Defective or incorrect tire. 4. Loose axle. 5. Incorrect front fork oil. 	Replace. Replace. Replace. Retighten. Adjust.
Front suspension too soft.	<ol style="list-style-type: none"> 1. Weakened springs. 2. Not enough fork oil. 	Replace. Refill.
Front suspension too stiff.	<ol style="list-style-type: none"> 1. Fork oil too viscous. 2. Too much fork oil. 	Replace. Drain excess oil.
Noisy front suspension.	<ol style="list-style-type: none"> 1. Not enough fork oil. 2. Loose bolts on suspension. 	Refill. Reighten.
Wobbly rear wheel.	<ol style="list-style-type: none"> 1. Distorted wheel rim. 2. Worn rear wheel bearing or swingarm bearings. 3. Defective or incorrect tire. 4. Worn swingarm and rear cushion related bearings. 5. Loose nuts or bolts on rear suspensions. 	Replace. Replace. Replace. Replace. Reighten.
Rear suspension too soft.	<ol style="list-style-type: none"> 1. Weakened shock absorber spring. 2. Rear suspension adjuster improperly set. 3. Oil leakage of shock absorber. 4. Gas leakage of shock absorber. 	Replace. Adjust. Replace. Replace.
Rear suspension too stiff.	<ol style="list-style-type: none"> 1. Rear suspension adjuster improperly set. 2. Shock absorber shaft bent. 3. Swingarm bent. 4. Worn swingarm and rear cushion related bearings. 	Adjust. Replace. Replace. Replace.
Noisy rear suspension.	<ol style="list-style-type: none"> 1. Loose nuts or bolts on rear suspension. 2. Worn swingarm and rear cushion related bearings. 	Retighten. Replace.

BRAKES

Complaint	Symptom and possible causes	Remedy
Insufficient brake power.	<ol style="list-style-type: none"> 1. Leakage of brake fluid from hydraulic system. 2. Worn pads. 3. Oil adhesion on engaging surface of pads. 4. Worn disc. 5. Air in hydraulic system. 	<p>Repair, or replace. Replace. Clean disc and pads. Replace. Bleed air.</p>
Brake squeaking.	<ol style="list-style-type: none"> 1. Carbon adhesion on pad surface. 2. Tilted pad. 3. Damaged wheel bearing. 4. Loose front-wheel axle or rear-wheel axle. 5. Worn pads. 6. Foreign material in brake fluid. 7. Clogged return port of master cylinder. 	<p>Repair surface with sandpaper. Modify pad fitting, or replace. Replace. Tighten to specified torque. Replace. Replace brake fluid. Disassemble and clean master cylinder.</p>
Excessive brake lever stroke.	<ol style="list-style-type: none"> 1. Air in hydraulic system. 2. Insufficient brake fluid. 3. Improper quality of brake fluid. 	<p>Bleed air. Replenish fluid to specified level; bleed air. Replace with correct fluid.</p>
Leakage of brake fluid.	<ol style="list-style-type: none"> 1. Insufficient tightening of connection joints. 2. Cracked hose. 3. Worn piston and/or cup. 	<p>Tighten to specified torque. Replace. Replace piston and/or cup.</p>

WIRING DIAGRAM

For U.S.A. and CANADA models



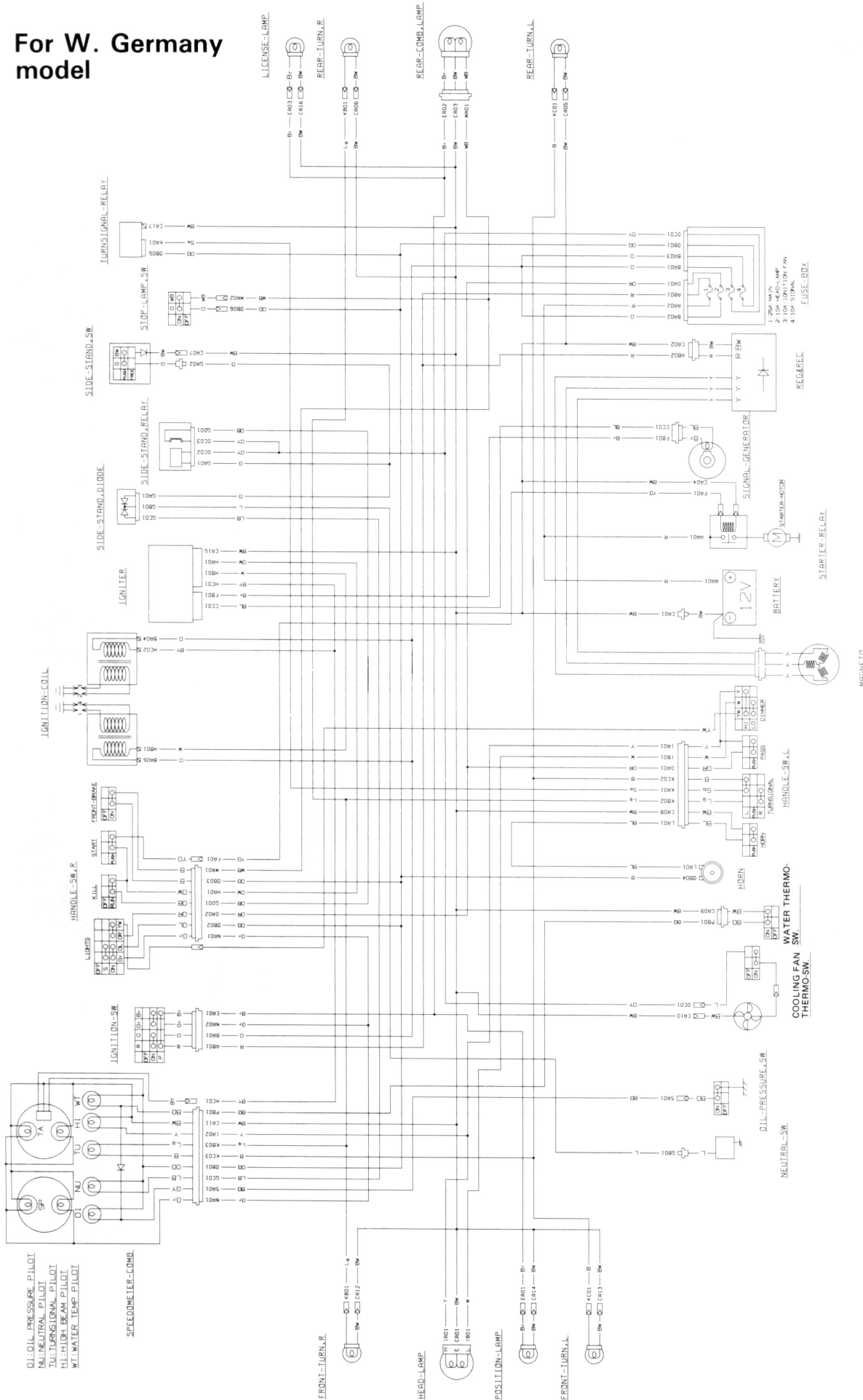
WIRE COLOR

B	Black	O/R	Orange with Red tracer
L	Blue	O/W	Orange with White tracer
Br	Brown	O/Y	Orange with Yellow tracer
G	Green	R/W	Red with White tracer
Gr	Gray	W/B	White with Black tracer
Sb	Light blue	Y/G	Yellow with Green tracer
Lg	Light green	Y/W	Yellow with White tracer
O	Orange	B/W	Black with White tracer
R	Red	B/Y	Black with Yellow tracer
W	White	L/B	Blue with Black tracer
Y	Yellow	G/Y	Green with Yellow tracer
B/Br	Black with Brown tracer	O/B	Orange with Black tracer
B/G	Black with Green tracer	O/Bl	Orange with Blue tracer
B/L	Black with Light blue tracer	O/G	Orange with Green tracer

OL: OIL PRESSURE PILOT
 NL: NEUTRAL PILOT
 TL: TURN SIGNAL PILOT
 HL: HIGH BEAM PILOT
 WT: WATER TEMP PILOT

1. 250A MAIN AMP
 2. 10A TURN SIGNAL
 3. 10A TURN SIGNAL
 4. 10A SIGNAL

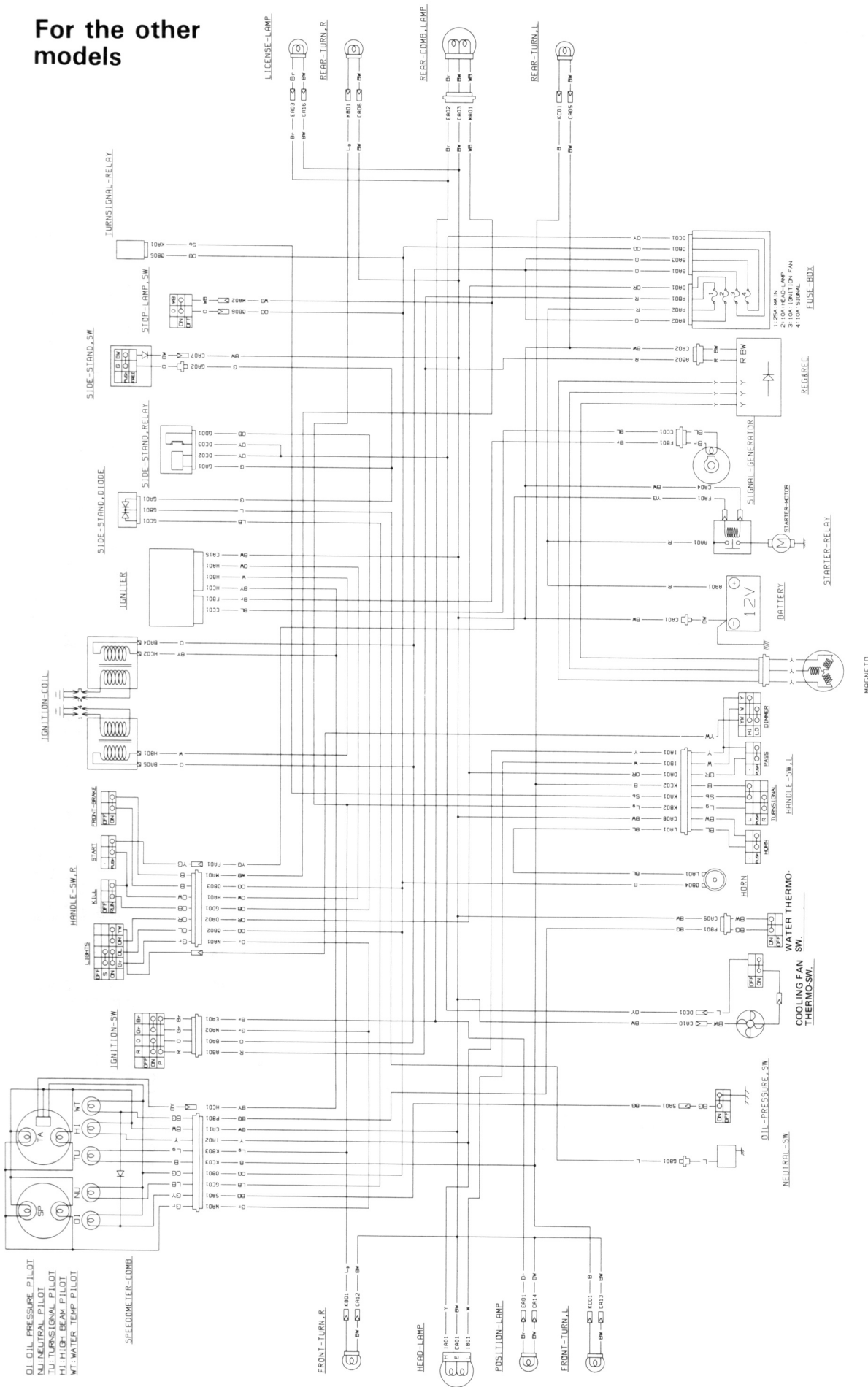
For W. Germany model



WIRE COLOR

B	Black
L	Blue
Br	Brown
G	Green
Gr	Gray
Sb	Light blue
Lg	Light green
O	Orange
R	Red
W	White
Y	Yellow
B/Br	Black with Brown tracer
B/G	Black with Green tracer
B/L	Black with Blue tracer
B/W	Black with White tracer
B/Y	Black with Yellow tracer
L/B	Blue with Black tracer
G/Y	Green with Yellow tracer
O/B	Orange with Black tracer
O/Bl	Orange with Blue tracer
O/G	Orange with Green tracer
O/R	Orange with Red tracer
O/W	Orange with White tracer
O/Y	Orange with Yellow tracer
R/W	Red with White tracer
W/B	White with Black tracer
Y/G	Yellow with Green tracer
Y/W	Yellow with White tracer

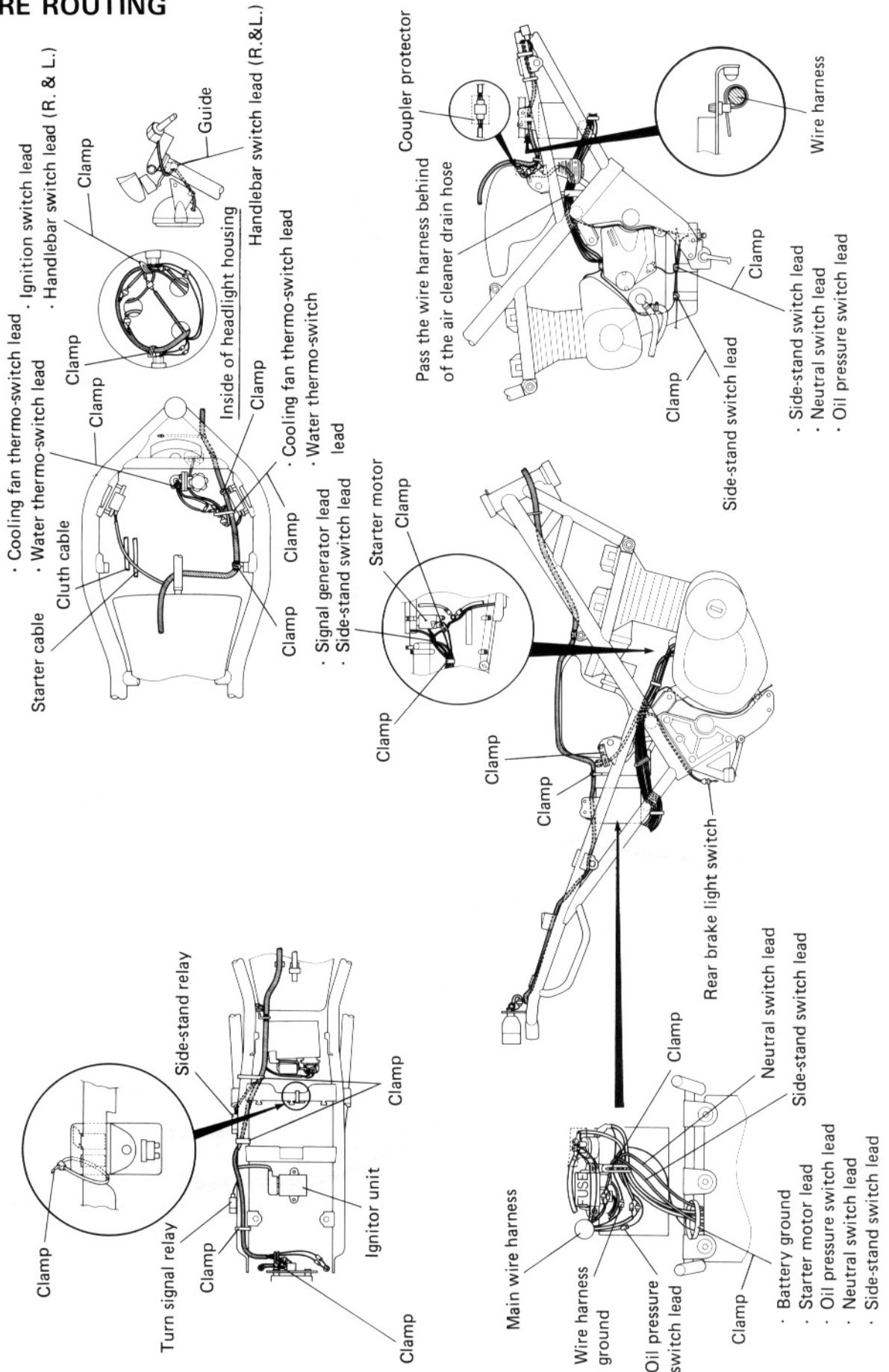
For the other models



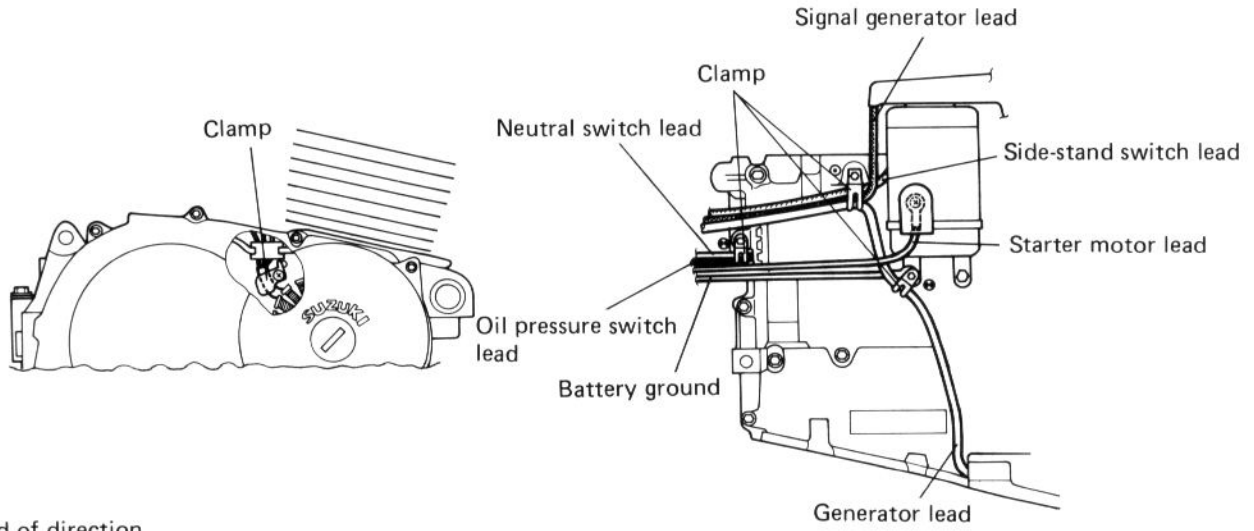
- WIRE COLOR**
- B Black
 - L Blue
 - Br Brown
 - G Green
 - Gr Gray
 - Sb Light blue
 - Lg Light green
 - O Orange
 - R Red
 - W White
 - Y Yellow
 - B/Br Black with Green tracer
 - B/G Black with Green tracer
 - B/L Black with Blue tracer
 - B/W Black with White tracer
 - B/Y Black with Yellow tracer
 - L/Y Blue with Yellow tracer
 - G/Y Green with Yellow tracer
 - O/B Orange with Blue tracer
 - O/G Orange with Green tracer
 - O/R Orange with Red tracer
 - O/W Orange with White tracer
 - O/Y Orange with Yellow tracer
 - R/W Red with White tracer
 - W/B White with Black tracer
 - Y/G Yellow with Green tracer
 - Y/W Yellow with White tracer

WIRE HARNESS, CABLE AND HOSE ROUTING

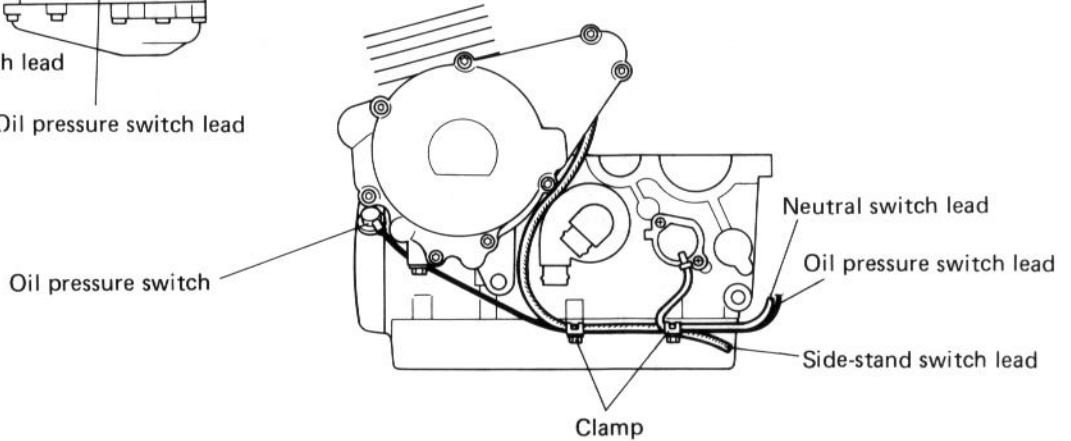
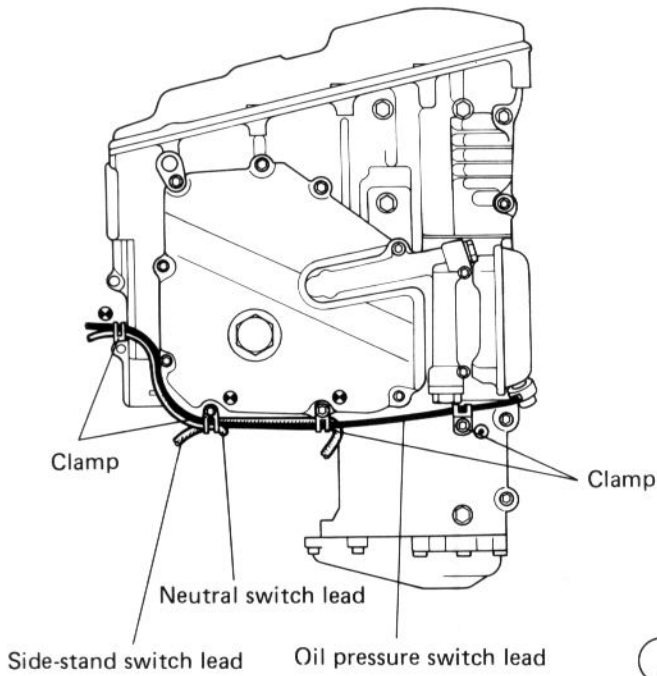
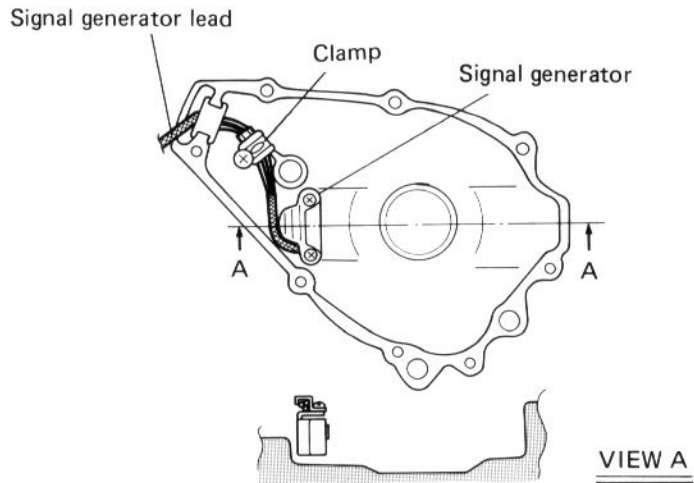
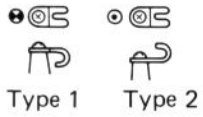
WIRE ROUTING



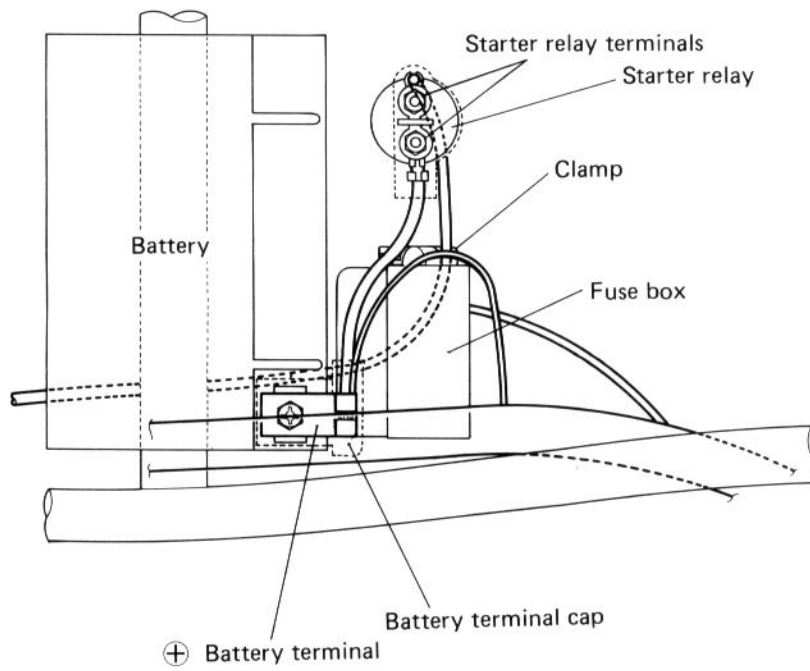
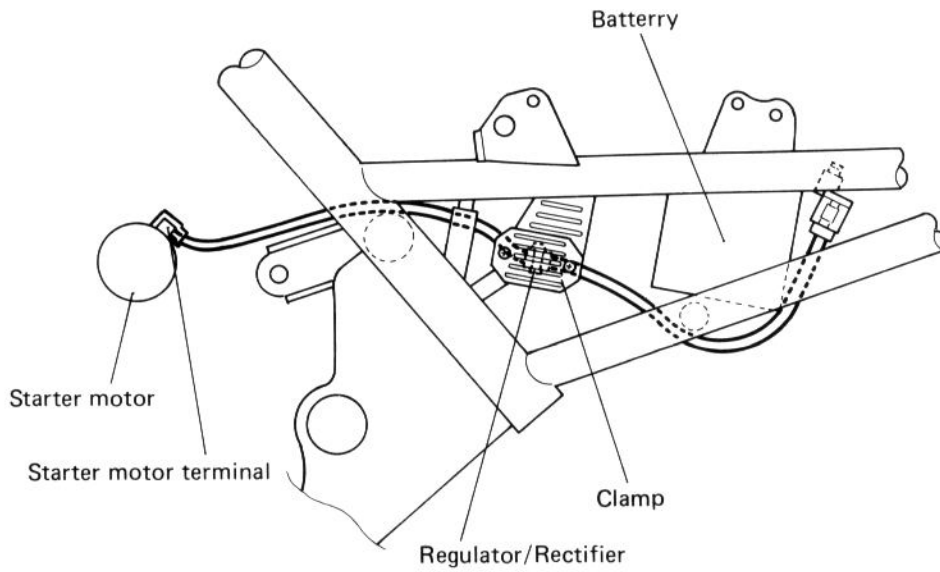
WIRE ROUTING



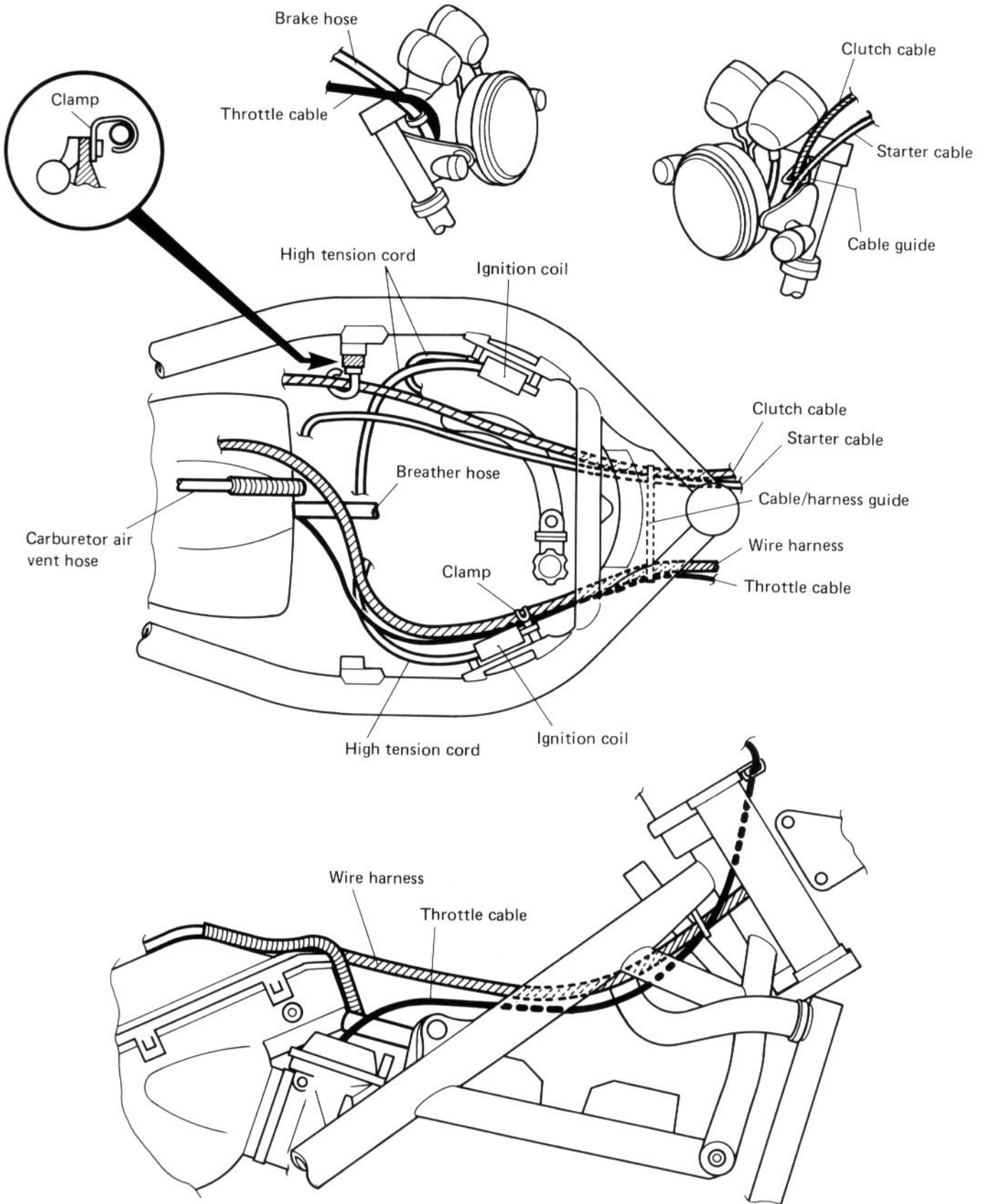
Bend of direction



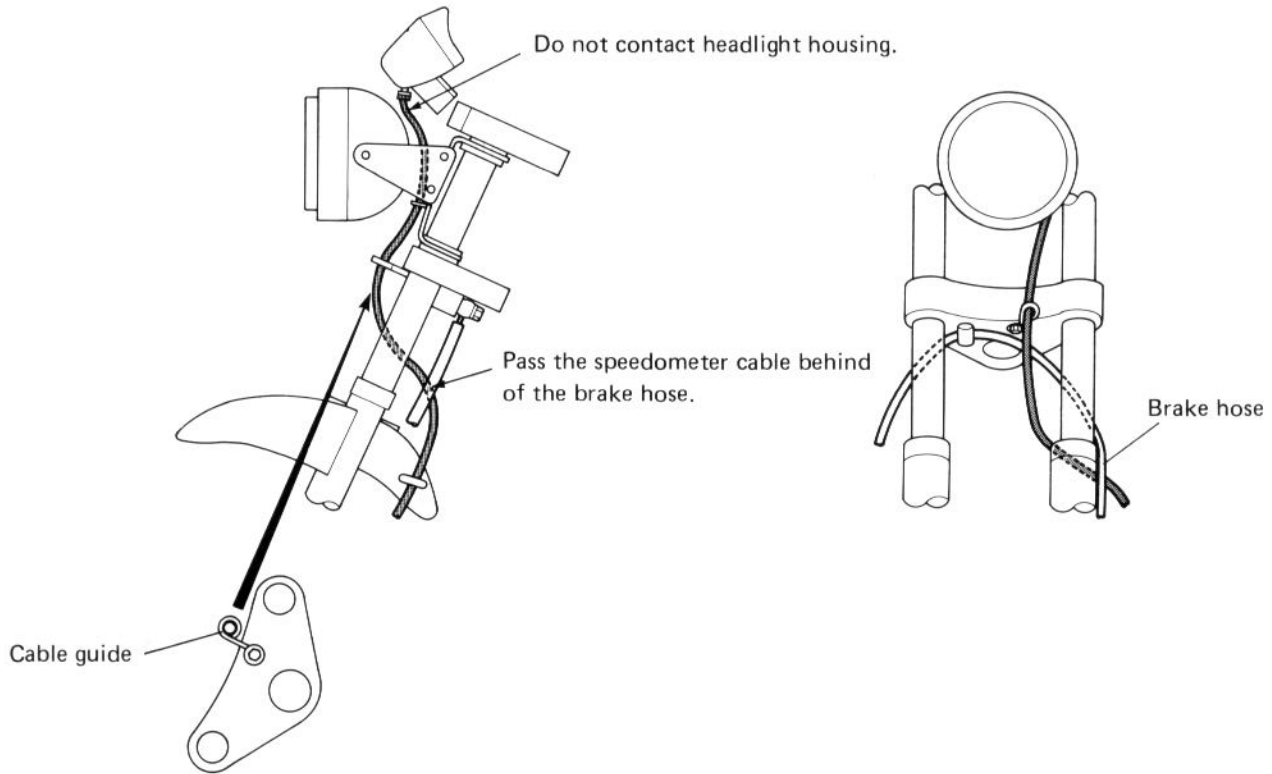
WIRE ROUTING



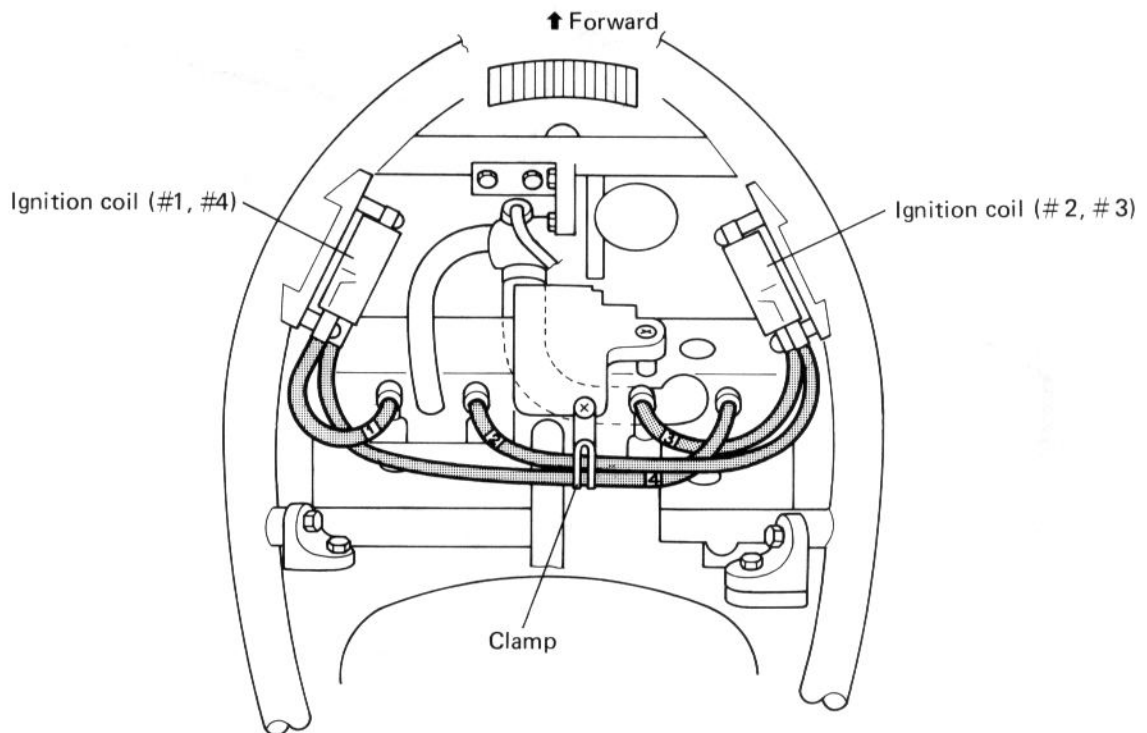
CABLE ROUTING



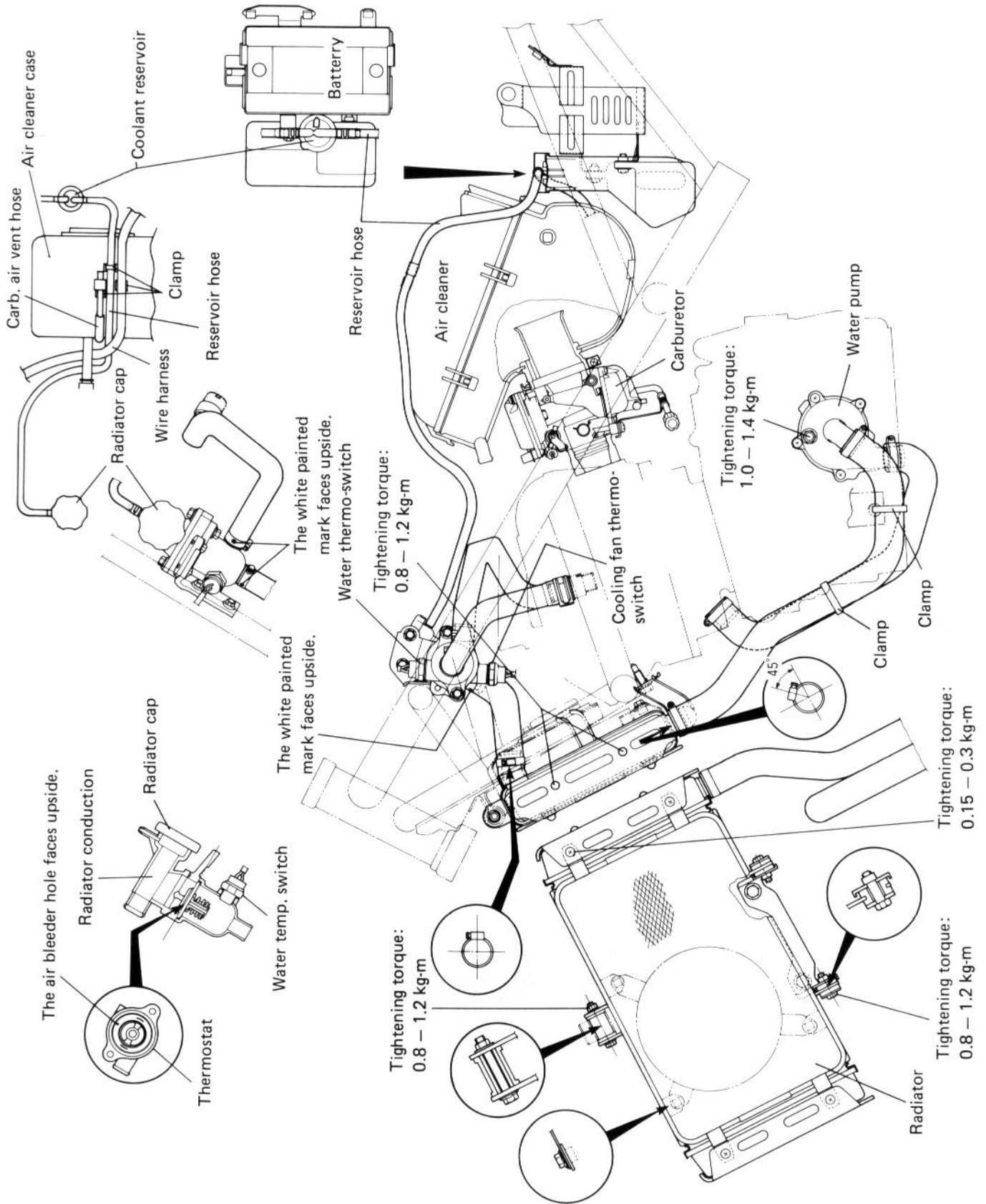
SPEEDOMETER CABLE ROUTING



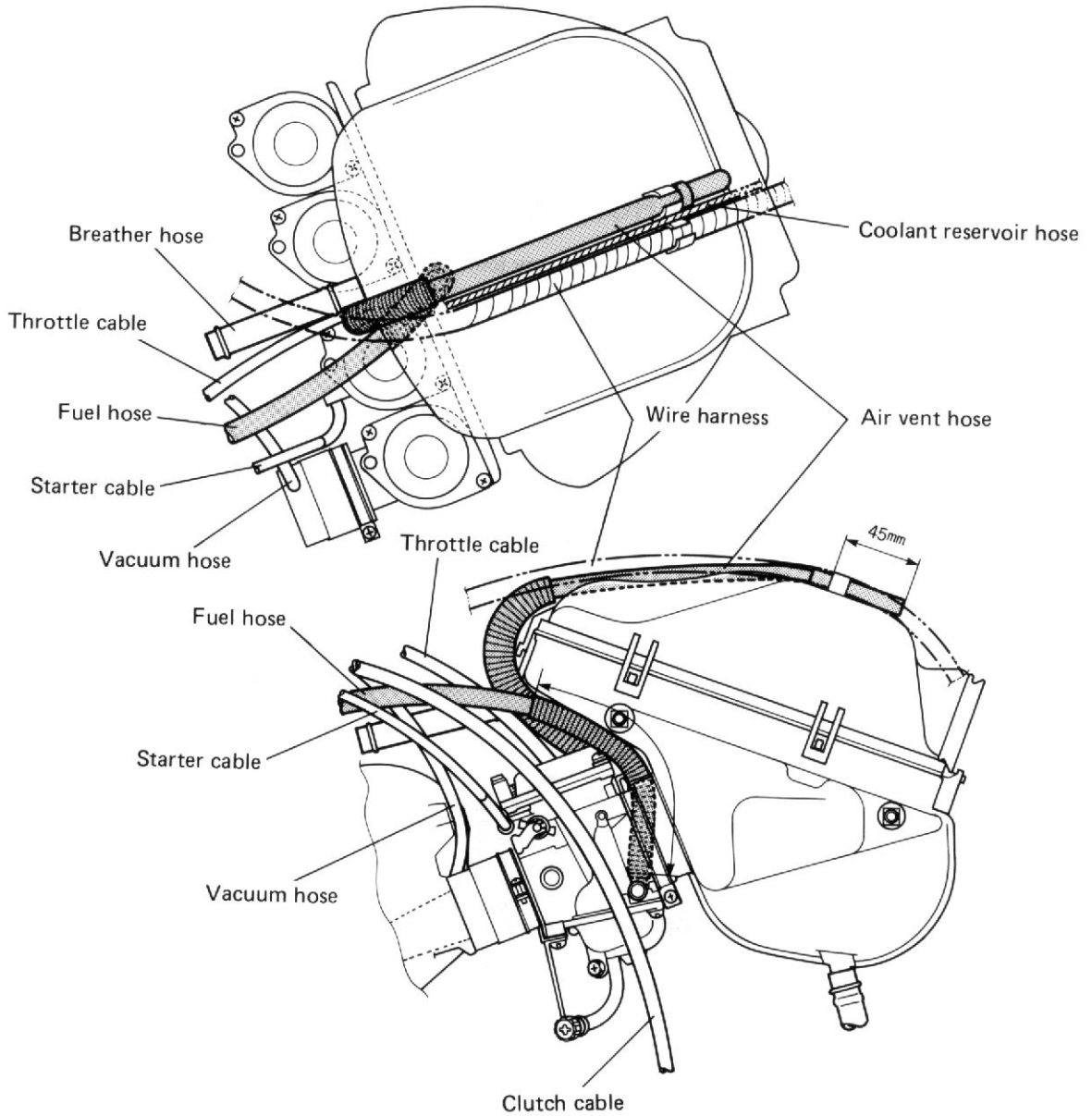
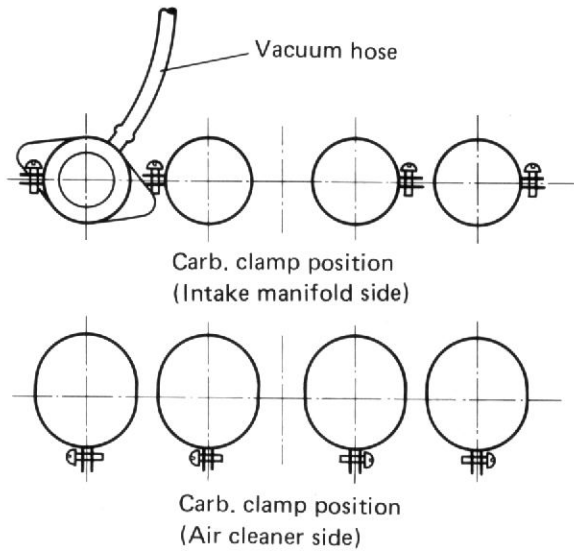
HIGH TENSION CORD ROUTING



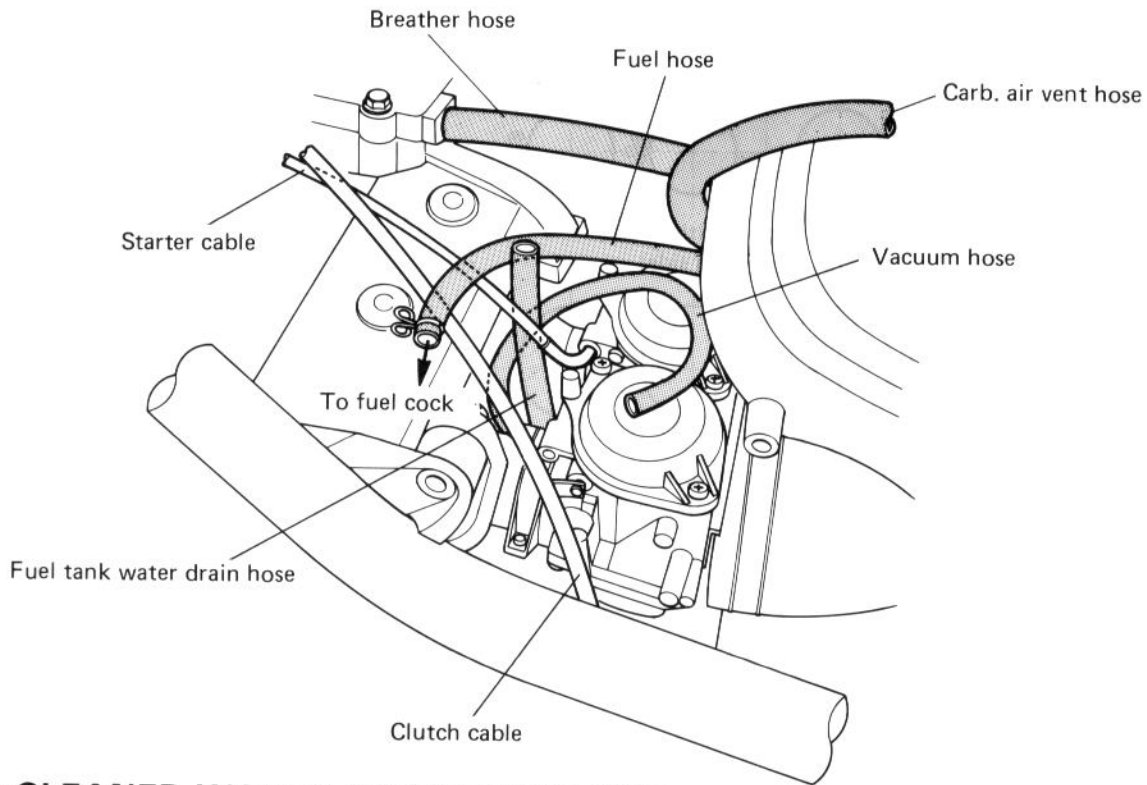
RADIATOR HOSE ROUTING



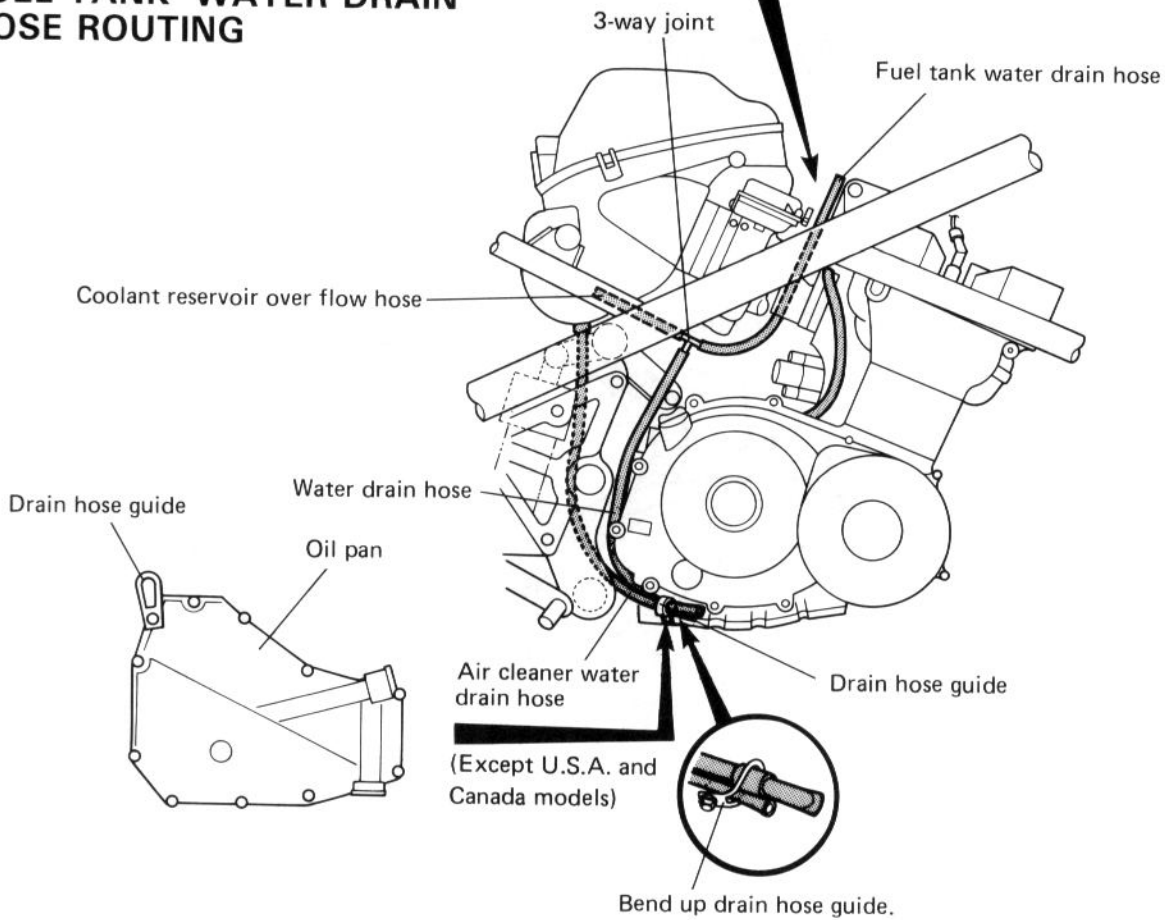
FUEL HOSE, VACUUM HOSE AND AIR VENT HOSE ROUTING



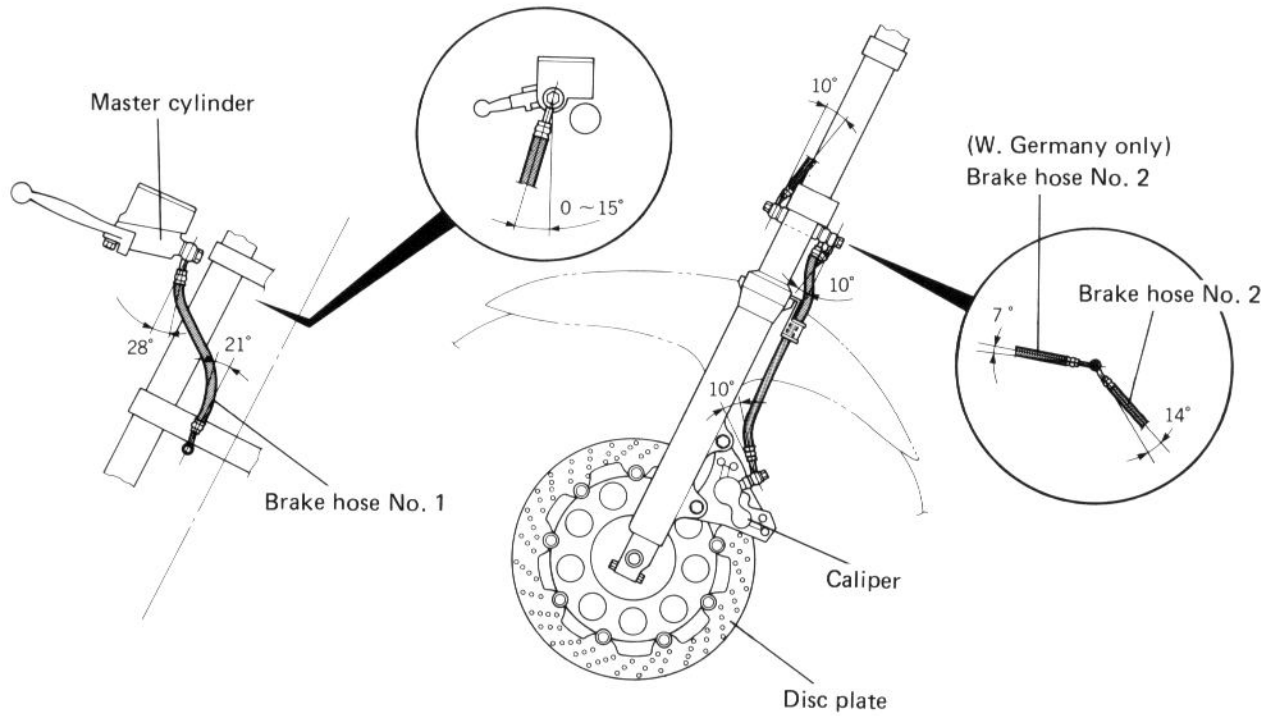
FUEL HOSE AND VACUUM HOSE ROUTING



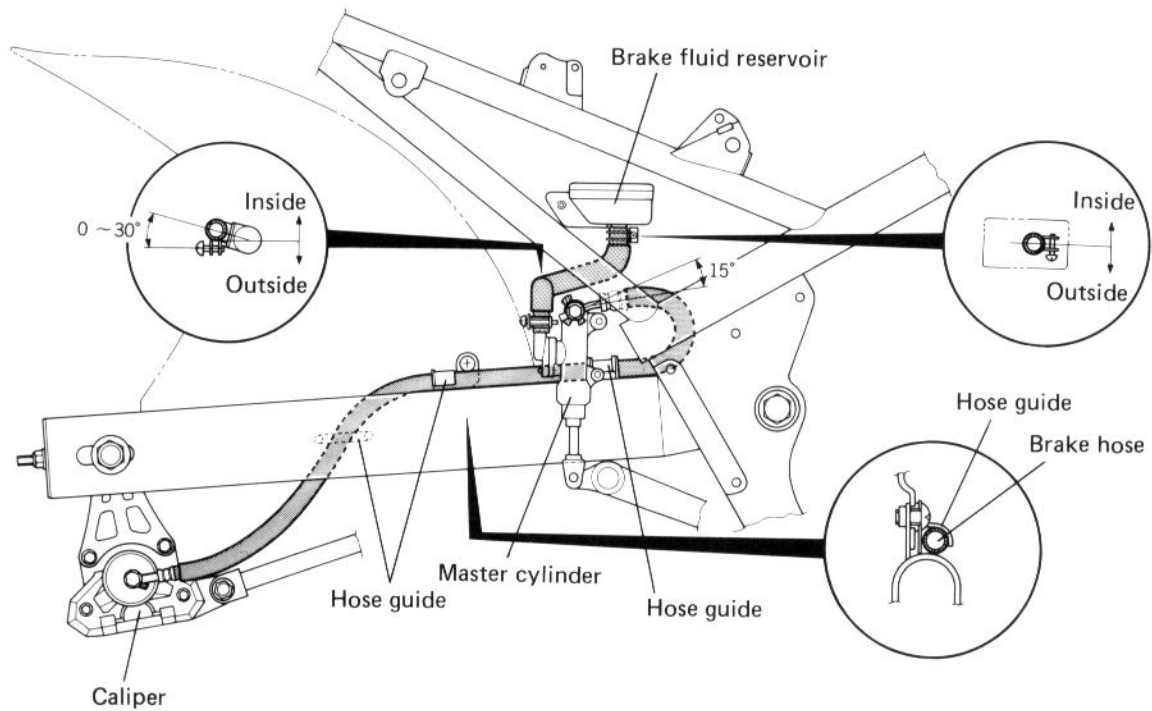
AIR CLEANER WATER DRAIN HOSE AND FUEL TANK WATER DRAIN HOSE ROUTING



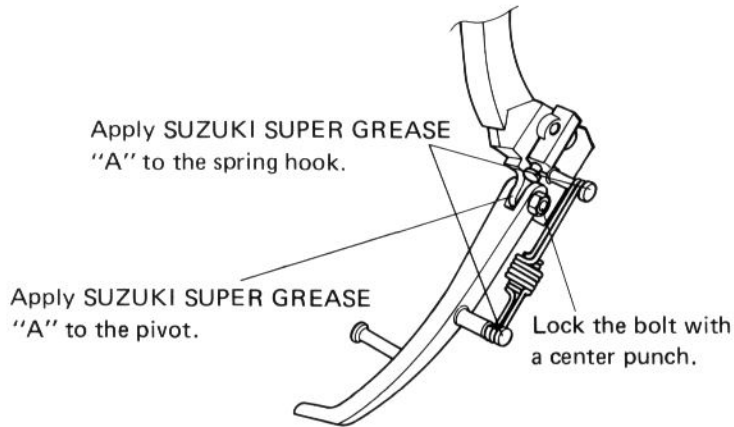
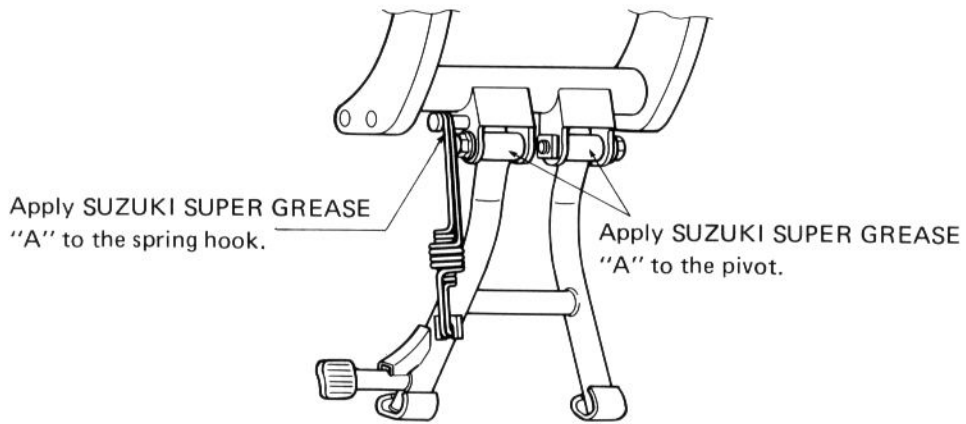
FRONT BRAKE HOSE ROUTING



REAR BRAKE HOSE ROUTING

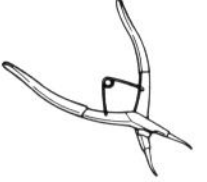


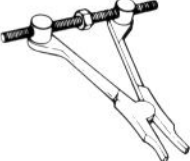




CENTER STAND SPRING AND SIDE-STAND SPRING

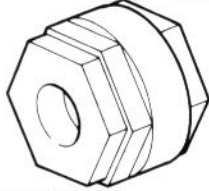



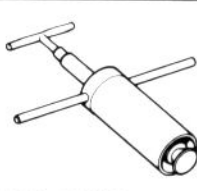



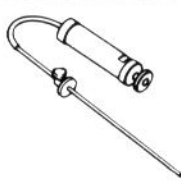
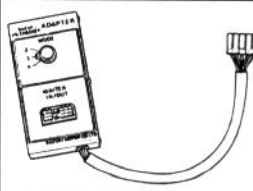


NOTE:
Be sure to bring the long arm side of the spring to top when fitting.

SPECIAL TOOLS

 <p>09900-00401 "L" type hexagon wrench set</p>	 <p>09900-00410 Hexagon wrench set</p>	 <p>09900-06105 Snap ring pliers</p>	 <p>09900-06107 Snap ring pliers</p>	 <p>09900-06108 Snap ring pliers</p>
 <p>09900-09003 Impact driver set</p>	 <p>09900-20102 Vernier calipers (1/20 mm, 200 mm)</p>	 <p>09900-20202 Micrometer (1/100 mm, 25-50 mm)</p>	 <p>09900-20203 Micrometer (1/100 mm, 50-75 mm)</p>	 <p>09900-20205 Micrometer (1/1000 mm, 0-25 mm)</p>
 <p>09900-20508 Cylinder gauge set (1/100 mm, 40-80 mm)</p>	 <p>09900-20602 Dial gauge (1/1000 mm, 1mm)</p>	 <p>09900-20605 Dial calipers (1/100 mm, 10-34 mm)</p>	 <p>09900-20606 Dial gauge (1/100 mm, 10 mm)</p>	 <p>09900-20701 Magnetic stand</p>
 <p>09900-20803 Thickness gauge</p>	 <p>09900-20805 Tire depth gauge</p>	 <p>09900-21304 V-block set (100 mm)</p>	 <p>09900-22301 Plastigauge</p>	 <p>09900-22401 Small bore gauge (10-18 mm)</p>
 <p>09900-25002 Pocket tester</p>	 <p>09900-28106 Electro tester</p>	 <p>09910-34510 Piston pin puller</p>	 <p>09911-73730 "T" type hexagon wrench (5 mm)</p>	 <p>09911-74520 Long socket (12 mm)</p>
 <p>09912-34510 Cylinder disassembler</p>	 <p>09913-13121 Carburetor balancer</p>	 <p>09913-75520 Bearing installer</p>	 <p>09914-24510 T-handle</p>	 <p>09914-25811 "T" type hexagon wrench (6 mm)</p>

 <p>09915-64510 Compression gauge 09915-63310 (Adaptor)</p>	 <p>09915-74510 Oil pressure gauge 09915-77330(Meter)</p>	 <p>09916-14510 Valve lifter</p>	 <p>09916-14910 Valve lifer attachment</p>	 <p>09916-20640 Solid pilot (N-100-4.5)</p>
 <p>09916-21110 Valve seat cutter set</p>	 <p>See page 3-24. Valve seat cutter head 45°, 15° and 60°</p>	 <p>09916-33210 Valve guide reamer (4.5 mm)</p>	 <p>09916-34542 Valve guide reamer handle</p>	 <p>09916-34580 Valve guide reamer (10.8 mm)</p>
 <p>09916-43210 Valve guide remover/ installer</p>	 <p>09916-43220 Attachment</p>	 <p>09916-74521 Piston ring compressor body</p>	 <p>09916-74530 Piston ring compressor band (53 – 65 mm)</p>	 <p>09916-84510 Tweezers</p>
 <p>09917-14920 Valve adjuster driver</p>	 <p>09920-13120 Crankcase separating tool</p>	 <p>09920-53710 Clutch sleeve hub holder</p>	 <p>09923-73210 Bearing puller (17 – 20 mm)</p>	 <p>09924-84510 Bearing installer set</p>
 <p>09924-84521 Bearing installer</p>	 <p>09930-10120 Spark plug socket wrench set</p>	 <p>09930-11910 Torx wrench</p>	 <p>09930-14530 Universal joint</p>	 <p>09930-30102 Sliding shaft</p>
 <p>09930-32420 Generator rotor holder</p>	 <p>09930-34960 Rotor remover</p>	 <p>09931-94430 Ignitor checker (Digital type)</p>	 <p>09940-14911 Steering stem nut wrench</p>	 <p>09940-34520 T-handle (Front fork disassembler)</p>

 <p>09940-34592 Attachment G (Front fork disassembler)</p>	 <p>09940-50113 Front fork oil seal installer</p>	 <p>09940-92710 Spring scale</p>	 <p>09941-34513 Steering outer race installer</p>	 <p>09941-44910 Swingarm bearing remover</p>
 <p>09941-50110 Bearing remover</p>	 <p>09941-74910 Steering bearing installer</p>	 <p>09941-84510 Bearing remover</p>	 <p>09943-74111 Front fork oil level gauge</p>	 <p>09931-94460 Adaptor (Ignitor checker)</p>

NOTE:

When ordering the special tool, please confirm whether it is available or not.

TIGHTENING TORQUE

ENGINE

ITEM	N·m	kg·m	lb·ft
Cylinder head cover bolt	8 – 12	0.8 – 1.2	6.0 – 8.5
Cylinder head oil pipe bolt	8 – 12	0.8 – 1.2	6.0 – 8.5
Cylinder head nut	25 – 29	2.5 – 2.9	18.0 – 21.0
Cylinder head bolt	8 – 12	0.8 – 1.2	6.0 – 8.5
Cylinder stud bolt	13 – 16	1.3 – 1.6	9.5 – 11.5
Valve clearance adjuster lock nut	9 – 11	0.9 – 1.1	6.5 – 8.0
Camshaft journal holder bolt	8 – 12	0.8 – 1.2	6.0 – 8.5
Cam sprocket bolt	24 – 26	2.4 – 2.6	17.5 – 19.0
Rocker arm shaft set bolt	8 – 10	0.8 – 1.0	6.0 – 7.0
Rocker arm shaft plug	25 – 30	2.5 – 3.0	18.0 – 21.5
Oil hose union bolt (Cylinder head side)	18 – 22	1.8 – 2.2	13.0 – 16.0
Oil hose union bolt (Crankcase side)	20 – 24	2.0 – 2.4	14.5 – 17.5
Cam chain tensioner mounting bolt	6 – 8	0.6 – 0.8	4.5 – 6.0
Conrod bearing cap nut	28.5 – 31.5	2.85 – 3.15	20.5 – 23.0
Starter clutch mounting bolt	85 – 95	8.5 – 9.5	61.5 – 68.5
Generator rotor bolt	110 – 130	11.0 – 13.0	79.5 – 94.0
Crankcase bolt (6 mm)	9 – 13	0.9 – 1.3	6.5 – 9.5
(8 mm)	28 – 32	2.8 – 3.2	20.0 – 23.0
Oil pump mounting bolt	8 – 12	0.8 – 1.2	6.0 – 8.5
Oil drain plug	20 – 25	2.0 – 2.5	14.5 – 18.0
Oil pan bolt	6 – 10	0.6 – 1.0	4.5 – 7.0
Oil filter cap nut	12 – 16	1.2 – 1.6	8.5 – 11.5
Oil pressure switch	12 – 15	1.2 – 1.5	8.5 – 11.0
Oil pressure regulator	25 – 30	2.5 – 3.0	18.0 – 21.5
Clutch sleeve hub nut	50 – 70	5.0 – 7.0	36.0 – 50.5
Clutch spring set bolt	7 – 11	0.7 – 1.1	5.0 – 8.0
Exhaust pipe bolt	18 – 28	1.8 – 2.8	13.0 – 20.0
Muffler mounting bolt	18 – 28	1.8 – 2.8	13.0 – 20.0
Engine mount- (L: 55 mm)	22 – 30	2.2 – 3.0	16.0 – 21.5
ing bolt (L: 145 mm, 135 mm and 70 mm)	60 – 72	6.0 – 7.2	43.5 – 52.5

CHASSIS

ITEM		N·m	kg·m	lb·ft
Steering stem head nut		50 – 80	5.0 – 8.0	36.0 – 58.0
Front fork upper clamp bolt		40 – 60	4.0 – 6.0	29.0 – 43.5
Front fork lower clamp bolt		28 – 44	2.8 – 4.4	20.0 – 32.0
Front axle shaft		50 – 80	5.0 – 8.0	36.0 – 58.0
Front axle pinch bolt		18 – 28	1.8 – 2.8	13.0 – 20.0
Handlebar clamp bolt		18 – 28	1.8 – 2.8	13.0 – 20.0
Front footrest bracket mounting bolt		18 – 28	1.8 – 2.9	13.0 – 20.0
Front brake master cylinder mounting bolt		5 – 8	0.5 – 0.8	3.5 – 6.0
Front brake caliper mounting bolt		30 – 48	3.0 – 4.8	21.5 – 35.0
Front brake caliper housing bolt		30 – 36	3.0 – 3.6	21.5 – 26.0
Brake hose union bolt		15 – 20	1.5 – 2.0	11.0 – 14.5
Air bleeder valve		6 – 9	0.6 – 0.9	4.5 – 6.5
Front and rear disc bolt		18 – 28	1.8 – 2.8	13.0 – 20.0
Swingarm pivot nut		85 – 115	8.5 – 11.5	61.5 – 83.0
Rear shock absorber upper/lower mounting nut		48 – 72	4.8 – 7.2	34.5 – 52.0
Rear cushion lever mounting nut		84 – 120	8.4 – 12.0	60.5 – 87.0
Rear cushion lever rod mounting nut (Upper & Lower)		84 – 120	8.4 – 12.0	60.5 – 87.0
Rear brake caliper mounting bolt		20 – 31	2.0 – 3.1	14.5 – 22.5
Rear brake caliper housing bolt		30 – 36	3.0 – 3.6	21.5 – 26.0
Torque link nut (Front & Rear)	Normal nut with cotter pin	22 – 35	2.2 – 3.5	16.0 – 25.5
	Self-lock nut	25 – 39	2.5 – 3.9	18.0 – 28.0
Rear brake pedal boss nut		35 – 55	3.5 – 5.5	25.5 – 40.0
Rear brake push rod lock nut		15 – 20	1.5 – 2.0	11.0 – 14.5
Rear brake master cylinder mounting bolt		8 – 12	0.8 – 1.2	6.0 – 8.5
Rear axle nut	Normal nut with cotter pin	50 – 80	5.0 – 8.0	36.0 – 58.0
	Self-lock nut	55 – 88	5.5 – 8.8	40.0 – 63.5
Rear sprocket nut		40 – 60	4.0 – 6.0	29.0 – 43.5

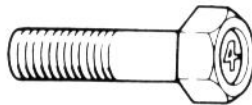
TIGHTENING TORQUE CHART

For other bolts and nuts not listed previously, refer to this chart:

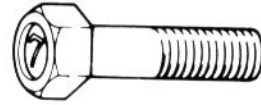
Bolt Diameter Ⓐ (mm)	Conventional or "4" marked bolt			"7" marked bolt		
	N-m	kg-m	lb-ft	N-m	kg-m	lb-ft
4	1.0 – 2.0	0.1 – 0.2	0.7 – 1.5	1.5 – 3.0	0.15 – 0.3	1.0 – 2.0
5	2.0 – 4.0	0.2 – 0.4	1.5 – 3.0	3.0 – 6.0	0.3 – 0.6	2.0 – 4.5
6	4.0 – 7.0	0.4 – 0.7	3.0 – 5.0	8.0 – 12.0	0.8 – 1.2	6.0 – 8.5
8	10.0 – 16.0	1.0 – 1.6	7.0 – 11.5	18.0 – 28.0	1.8 – 2.8	13.0 – 20.0
10	22.0 – 35.0	2.2 – 3.5	16.0 – 25.5	40.0 – 60.0	4.0 – 6.0	29.0 – 43.5
12	35.0 – 55.0	3.5 – 5.5	25.5 – 40.0	70.0 – 100.0	7.0 – 10.0	50.5 – 72.5
14	50.0 – 80.0	5.0 – 8.0	36.0 – 58.0	110.0 – 160.0	11.0 – 16.0	79.5 – 115.5
16	80.0 – 130.0	8.0 – 13.0	58.0 – 94.0	170.0 – 250.0	17.0 – 25.0	123.0 – 181.0
18	130.0 – 190.0	13.0 – 19.0	94.0 – 137.5	200.0 – 280.0	20.0 – 28.0	144.5 – 202.5



Conventional bolt



"4" marked bolt



"7" marked bolt

SERVICE DATA

VALVE + GUIDE

Unit: mm (in)

ITEM		STANDARD		LIMIT
Valve diam.		IN.	22.4 (0.88)	—
		EX.	20.0 (0.79)	—
Valve lift	E-33	IN.	6.5 (0.26)	—
	The others		7.6 (0.30)	—
		EX.	7.0 (0.28)	—
Valve clearance (when cold)		IN.	0.10–0.15 (0.004–0.006)	—
		EX.	0.15–0.20 (0.006–0.008)	—
Valve guide to valve stem clearance		IN.	0.025–0.052 (0.0010–0.0020)	—
		EX.	0.040–0.067 (0.0016–0.0026)	—
Valve stem deflection		IN. & EX.	—	0.35 (0.014)
Valve guide I.D.		IN. & EX.	4.500–4.512 (0.1772–0.1776)	—
Valve stem O.D.		IN.	4.460–4.475 (0.1756–0.1762)	—
		EX.	4.445–4.460 (0.1750–0.1756)	—
Valve stem runout		IN. & EX.	—	0.05 (0.002)
Valve head thickness		IN. & EX.	—	0.5 (0.02)
Valve stem end length		IN. & EX.	—	2.7 (0.11)
Valve seat width		IN. & EX.	0.7–0.9 (0.03–0.04)	—
Valve head radial runout		IN. & EX.	—	0.03 (0.001)
Valve spring free length (IN. & EX.)		INNER	—	32.6 (1.28)
		OUTER	—	37.3 (1.47)
Valve spring tension (IN. & EX.)		INNER	6.5–7.5 kg (14.3–16.5 lbs) at length 28.6 mm (1.13 in)	—
		OUTER	8.8–10.2 kg (19.4–22.5 lbs) at length 31.6 mm (1.24 in)	—

CAMSHAFT + CYLINDER HEAD

Unit: mm (in)

ITEM		STANDARD		LIMIT
Cam height	E-33	IN.	32.530–32.570 (1.2807–1.2823)	32.230 (1.2689)
	The others		33.134–33.174 (1.3045–1.3061)	32.840 (1.2929)
		EX.	32.839–32.879 (1.2929–1.2944)	32.540 (1.2811)
Camshaft journal oil clearance		IN. & EX.	0.032–0.066 (0.0013–0.0026)	0.150 (0.0059)
Camshaft journal holder I.D.		IN. & EX.	22.012–22.025 (0.8666–0.8671)	—
Camshaft journal O.D.		IN. & EX.	21.959–21.980 (0.8645–0.8654)	—
Camshaft runout		IN. & EX.	—	0.10 (0.004)
Cam chain 20-pitch length			—	143 (5.63)
Cam chain pin (at arrow "3")			20 th pin	—
Rocker arm I.D.		IN. & EX.	12.000–12.018 (0.4724–0.4731)	—
Rocker arm shaft O.D.		IN. & EX.	11.973–11.984 (0.4714–0.4718)	—
Cylinder head distortion			—	0.20 (0.008)

CYLINDER + PISTON + PISTON RING

Unit: mm (in)

ITEM		STANDARD		LIMIT
Compression pressure			1000–1450 kPa (10–14.5 kg/cm ²) (142–206 psi)	800 kPa (8 kg/cm ²) (114 psi)
Compression pressure difference			—	200 kPa (2 kg/cm ²) (28 psi)
Piston to cylinder clearance			0.050–0.060 (0.0020–0.0024)	0.120 (0.0047)
Cylinder bore			56.000–56.015 (2.2047–2.2053)	56.080 (2.2079)
Piston diam.			55.945–55.960 (2.2026–2.2031)	55.880 (2.2000)
Cylinder distortion			—	0.20 (0.008)
Piston ring free end gap	1st	R	Approx. 5.6 (0.22)	4.5 (0.18)
	2nd	RN	Approx. 5.7 (0.22)	4.6 (0.18)
Piston ring end gap	1st		0.15–0.30 (0.006–0.012)	0.5 (0.02)
	2nd		0.10–0.30 (0.004–0.012)	0.5 (0.02)

ITEM	STANDARD		LIMIT
Piston ring to groove clearance	1st	—	0.180 (0.0071)
	2nd	—	0.150 (0.0059)
Piston ring groove width	1st	0.81–0.83 (0.032–0.033)	—
	2nd	0.81–0.83 (0.032–0.033)	—
	Oil	1.51–1.53 (0.059–0.060)	—
Piston ring thickness	1st	0.77–0.79 (0.030–0.031)	—
	2nd	0.77–0.79 (0.030–0.031)	—
Piston pin bore	16.002–16.008 (0.6300–0.6302)		16.030 (0.6311)
Piston pin O.D.	15.995–16.000 (0.6297–0.6299)		15.980 (0.6291)

CONROD + CRANKSHAFT

Unit: mm (in)

ITEM	STANDARD		LIMIT
Conrod small end I.D.	16.010–16.018 (0.6303–0.6306)		16.040 (0.6315)
Conrod big end side clearance	0.10–0.20 (0.004–0.008)		0.30 (0.012)
Conrod big end width	16.95–17.00 (0.667–0.669)		—
Crank pin width	17.10–17.15 (0.673–0.675)		—
Conrod big end oil clearance	0.024–0.048 (0.0009–0.0019)		0.080 (0.0031)
Crank pin O.D.	29.976–30.000 (1.1802–1.1811)		—
Crankshaft journal oil clearance	0.012–0.036 (0.0005–0.0014)		0.080 (0.0031)
Crankshaft journal O.D.	31.976–32.000 (1.2589–1.2598)		—
Crankshaft thrust bearing thickness	Left side	2.350–2.500 (0.0925–0.0984)	—
	Right side	2.425–2.450 (0.0955–0.0965)	—
Crankshaft thrust clearance	0.045–0.100 (0.0018–0.0039)		—
Crankshaft runout	—		0.05 (0.002)

OIL PUMP

ITEM	STANDARD	LIMIT
Oil pump reduction ratio	2.084 (86/44 x 32/30)	—
Oil pressure (at 60°C, 140°F)	Above 250 kPa (2.5 kg/cm ² , 36 psi) Below 600 kPa (6.0 kg/cm ² , 85 psi) at 3 000 r/min.	—

CLUTCH

Unit: mm (in)

ITEM	STANDARD	LIMIT
Clutch cable play	4 (0.16)	—
Clutch release screw	¼ – ½ turn back	—
Drive plate thickness	2.90 – 3.10 (0.114 – 0.122)	2.60 (0.102)
Drive plate claw width	11.8 – 12.0 (0.46 – 0.47)	11.0 (0.43)
Driven plate distortion	—	0.10 (0.004)
Clutch spring free length	—	31.0 (1.22)

THERMOSTAT + RADIATOR + FAN

ITEM	STANDARD	LIMIT	
Thermostat valve opening temperature	74.5 – 78.5°C (166.1 – 173.3°F)	—	
Thermostat valve lift	Over 7 mm (0.28 in) at 90°C (194°F)	—	
Radiator cap valve opening pressure	110 kPa (1.1 kg/cm ² , 15.6 psi)	—	
Cooling fan thermo-switch operating temperature	ON	Approx. 95°C (203 °F)	—
	OFF	Approx. 88°C (190.4 °F)	—
Water thermo-switch operating temperature	ON	Approx. 117°C (243°F)	—
	OFF	Approx. 110°C (230°F)	—

TRANSMISSION + DRIVE CHAIN

Unit: mm (in) Except ratio

ITEM	STANDARD	LIMIT	
Primary reduction ratio	1.954 (86/44)	—	
Final reduction ratio	3.357 (47/14)	—	
Gear ratios	Low	3.363 (37/11)	—
	2nd	2.307 (30/13)	—
	3rd	1.750 (28/16)	—
	4th	1.437 (23/16)	—
	5th	1.250 (30/24)	—
	Top	1.150 (23/20)	—
Shift fork to groove clearance	No. 1, No. 2 & No. 3	0.10 – 0.30 (0.004 – 0.012)	0.50 (0.020)
Shift fork groove width	No. 1, No. 2 & No. 3	5.5 – 5.6 (0.217 – 0.220)	—

ITEM	STANDARD		LIMIT
	No.1, No.2 & No.3	5.3–5.4 (0.209–0.213)	
Shift fork thickness	No.1, No.2 & No.3	5.3–5.4 (0.209–0.213)	—
Countershaft length (Low to 2nd)	113.1–113.2 (4.453–4.457)		—
Drive chain	Type	D.I.D.: DID525V ₉ TAKASAGO: RK525SMOZ ₂	—
	Links	114	—
	20-pitch length	—	319.4 (12.57)
Drive chain slack	25–35 (1.0–1.4)		—
Gearshift lever height	45 (1.8)		—

CARBURETOR

ITEM	SPECIFICATION	
	E-03	E-33
Carburetor type	MIKUNI BST32SS	←
Bore size	32 mm	←
I.D. No	10D2	10D4
Idle r/min.	1 400 ± 50 r/min.	←
Float height	14.6 ± 1.0 mm	←
Main jet (M.J.)	# 102.5	←
Main air jet (M.A.J.)	0.6 mm	←
Jet needle (J.N.)	5EZ74	←
Needle jet (N.J.)	D-9	←
Throttle valve (Th.V.)	# 130	←
Pilot jet (P.J.)	# 32.5	←
By-pass (B.P.)	#10.8, #20.8, #30.8 mm	←
Pilot outlet (P.O.)	0.8 mm	0.9 mm
Valve seat (V.S.)	2.0 mm	←
Starter jet (G.S.)	# 32.5	←
Pilot screw (P.S.)	PRE-SET	←
Throttle cable play	0.5–1.0 mm (0.02–0.04 in)	←

ITEM	SPECIFICATION		
	E-02,04,21,25,28,34	E-24	E-22
Carburetor type	BST33SS	←	←
Bore size	33 mm	←	←
I.D. No.	10D1	10D3	10D5
Idle r/min.	1 300 ± 100 r/min	←	1 400 ± 50 r/min
Float height	14.6 ± 1.0 mm	←	←
Main jet (M.J.)	# 100	←	←
Main air jet (M.A.J.)	0.6 mm	←	←
Jet needle (J.N.)	5EZ67-3rd	←	←
Needle jet (N.J.)	P-0	←	←
Throttle valve (Th.V.)	# 130	←	←
Pilot jet (P.J.)	# 32.5	←	←
By-pass (B.P.)	#10.8, #20.8, #30.8 mm	←	←

8-33 SERVICING INFORMATION

ITEM	SPECIFICATION		
	E-02,04,21,25,28,34	E-24	E-22
Pilot outlet (P.O.)	0.7 mm	←	←
Valve seat (V.S.)	2.0 mm	←	←
Starter jet (G.S.)	# 32.5	←	←
Pilot screw (P.S.)	PRE-SET (1½ turns back)	←	PRE-SET (1¼ turns back)
Throttle cable play	0.5–1.0 mm (0.02–0.04 in)	←	←

ELECTRICAL

Unit: mm (in)

ITEM	SPECIFICATION		NOTE
Ignition timing	7° B.T.D.C. below 1 500 r/min.		For California model
	15° B.T.D.C. below 1 500 r/min.		For the Other model
Firing order	1·2·4·3		
Spark plug	Type	ND.: U24ETR N.G.K.: CR8EK	
	Gap	0.6–0.7 (0.02–0.03)	
Spark performance	Over 8 (0.3) at 1 atm.		
Signal coil resistance	80–120 Ω		Tester range: x 10 Ω
Ignition coil resistance	Primary	⊕ tap–⊖ tap 2.5–3.8 Ω	Tester range: x 1 Ω
	Secondary	Plug cap–Plug cap 30–50 k Ω	Tester range: x 1 kΩ
Generator no-load voltage	More than 70 V (AC) at 5 000 r/min.		When cold
Regulated voltage	13.5–15.5 V at 5 000 r/min.		
Starter motor brush length	Limit: 3.5 (0.14)		
Commutator under-cut	Limit: 0.5 (0.02)		
Starter relay resistance	3–5 Ω		
Battery	Type designation	YTX9-BS	
	Capacity	12V 28.8 kC (8 Ah)/10 HR	
	Standard electrolyte S.G.	1.32 at 20°C (68°F)	
Fuse size	Headlight	15 A	
	Signal	10 A	
	Ignition	10 A	
	Main	25 A	

WATTAGE

Unit:W

ITEM	SPECIFICATION	
Headlight	HI	60
	LO	55
Parking or position light	4 (Except E-03,28 and 33)	
Tail/Brake light	5/21	
Turn signal light	21	
Tachometer light	1.7 x 2pcs	
Speedometer light	1.7 x 2pcs	

ITEM	SPECIFICATION
Water temp. check light	3.4
Turn signal indicator light	3.4
High beam indicator light	1.7
Neutral indicator light	3
Oil pressure indicator light	3.4
License light	5

BRAKE + WHEEL

Unit: mm (in)

ITEM	STANDARD		LIMIT
Rear brake pedal height	45 (1.8)		—
Brake disc thickness	Front	4.5 ± 0.2 (0.18 ± 0.008)	4.0 (0.16)
	Rear	6.0 ± 0.2 (0.24 ± 0.008)	5.5 (0.22)
Brake disc runout	—		0.30 (0.012)
Master cylinder bore	Front	12.700–12.743 (0.5000–0.5017)	—
	Rear	12.700–12.743 (0.5000–0.5017)	—
Master cylinder piston diam.	Front	12.657–12.684 (0.4983–0.4994)	—
	Rear	12.657–12.684 (0.4983–0.4994)	—
Brake caliper cylinder bore	Front	27.000–27.076 (1.0630–1.0660)	—
		33.960–34.036 (1.3370–1.3400)	—
	Rear	38.180–38.256 (1.5031–1.5061)	—
Brake caliper piston diam.	Front	26.920–26.970 (1.0598–1.0618)	—
		33.884–33.934 (1.3340–1.3360)	—
	Rear	38.098–38.148 (1.4999–1.5019)	—
Wheel rim runout	Axial	—	2.0 (0.08)
	Radial	—	2.0 (0.08)
Wheel axle runout	Front	—	0.25 (0.010)
	Rear	—	0.25 (0.010)
Tire size	Front	110/70-17 54H	—
	Rear	150/70-17 69H	—
Tire tread depth	Front	—	1.6 (0.06)
	Rear	—	2.0 (0.08)

SUSPENSION

Unit: mm (in)

ITEM	STANDARD	LIMIT	NOTE
Front fork stroke	120 (4.72)	—	
Front fork spring free length	—	262 (10.3)	
Front fork oil level	106 (4.17)	—	For E-03,28 and 33 models
	105 (4.13)	—	For the other models
Rear shock absorber spring adjuster	4/7	—	
Rear wheel travel	120 (4.72)	—	
Swingarm pivot shaft runout	—	0.3 (0.01)	

TIRE PRESSURE

COLD INFLATION TIRE PRESSURE	SOLO RIDING			DUAL RIDING		
	kPa	kg/cm ²	psi	kPa	kg/cm ²	psi
FRONT	200	2.00	29	200	2.00	29
REAR	225	2.25	33	250	2.50	36

FUEL + OIL + COOLANT

ITEM	SPECIFICATION	NOTE
Fuel type	Use only unleaded gasoline of at least 87 pump octane ($\frac{R+M}{2}$) or 91 octane or higher rated by the research method. Gasoline containing MTBE (Methyl Tertiary Butyl Ether), less than 10% ethanol, or less than 5% methanol with appropriate cosolvents and corrosion inhibitor is permissible.	For U.S.A. model
	Use only unleaded gasoline of at least 87 pump octane ($\frac{R+M}{2}$ method) or 91 octane or higher rated by the Reserch Method.	For Canada model
	Gasoline used should be graded 85-95 octane or higher. An unleaded gasoline is recommended.	For the other models
Fuel tank including reserve	14.5 L (3.8/3.2 US/Imp gal)	For California model
	16 L (4.2/3.5 US/Imp gal)	For the other models
	reserve 3.5 L (0.9/0.8 US/Imp gal)	
Engine oil type	SAE 10W/40, API SE or SF	
Engine oil capacity	Change 2 300 ml (2.4/2.0 US/Imp qt)	
	Filter change 2 800 ml (3.0/2.5 US/Imp qt)	
	Overhaul 3 200 ml (3.4/2.8 US/Imp qt)	

ITEM	SPECIFICATION	NOTE
Front fork oil type	Fork oil # 10	
Front fork oil capacity (each leg)	494 ml (16.7/17.4 US/lmp oz)	For E-03,28 and 33 models
	495 ml (16.7/17.4 US/lmp oz)	For the other models
Brake fluid type	DOT3 or DOT4	
Coolant type	Use an anti-freeze/coolant compatible with aluminum radiator, mixed with distilled water only, at the ratio of 50:50.	
Coolant including reserve	1 900 ml (2.0/1.7 US/lmp qt)	

EMISSION CONTROL INFORMATION

CONTENTS

EMISSION CONTROL CARBURETOR COMPONENTS.....	9- 1
EVAPORATIVE EMISSION CONTROL SYSTEM.....	9- 2
CANISTER HOSE ROUTING.....	9- 3

EMISSION CONTROL CARBURETOR COMPONENTS

GSF400/BANDIT motorcycles are equipped with precision, manufactured carburetors for emission level control.

These carburetors require special mixture control components and other precision adjustments to function properly.

There are several carburetor mixture control components in each carburetor assembly. Three (3) of these components are machined to much closer tolerances than standard machined carburetor jets. These three (3) particular jets — MAIN JET, NEEDLE JET, PILOT JET — must not be replaced by standard jets. To aid in identifying these three (3) jets a different design of letter and number are used. If replacement of these close tolerance jets becomes necessary, be sure to replace them with the same type close tolerance jets marked as in the examples shown below.

The jet needle is also of special manufacture. Only one clip position is provided on the jet needle. If replacement becomes necessary the jet needle may only be replaced with an equivalent performing replacement component. Suzuki recommends that Genuine Suzuki Parts be utilized whenever possible for the best possible performance and durability.

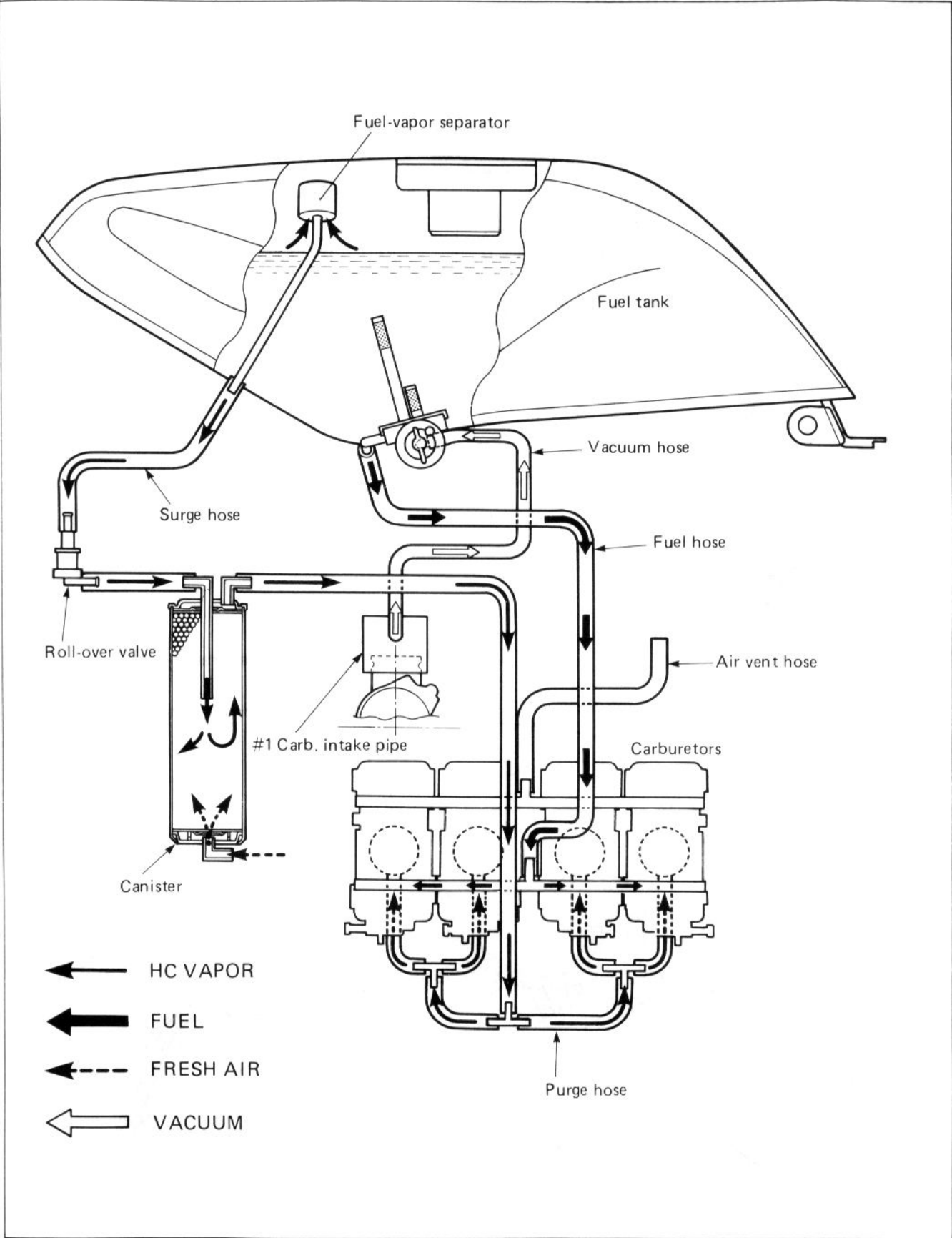
Conventional Figures Used on Standard Tolerance Jet Components	1 2 3 4 5 6 7 8 9 0
Emission Type Figures Used On Close Tolerance jet Components	1 2 3 4 5 6 7 8 9 0

The carburetor specification for the emission-controlled GSF400/BANDIT are as follows.

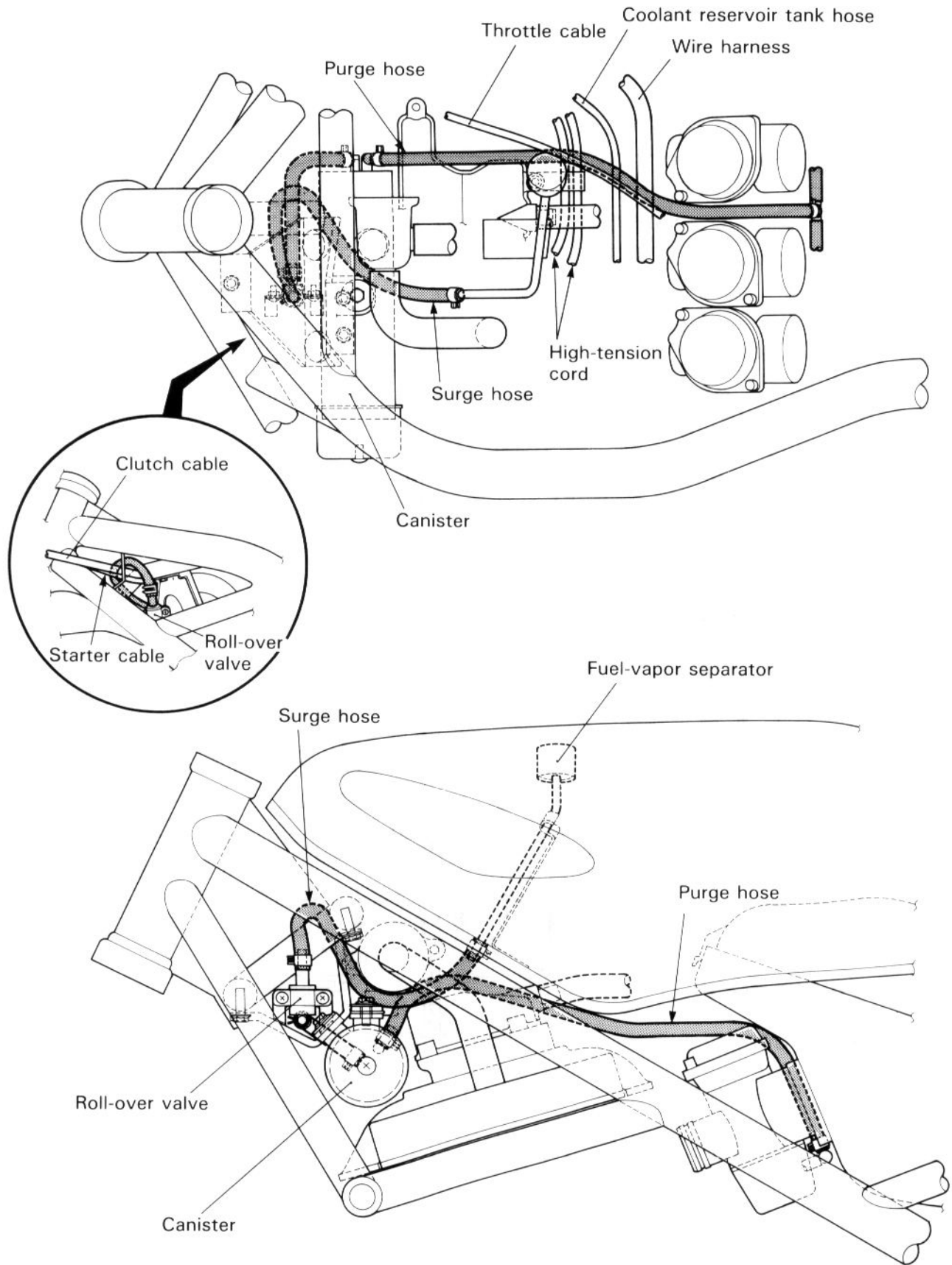
Carburetor I.D. No.	Main Jet	Needle Jet	Jet Needle	Pilot Jet	Pilot Screw
10D4 (California model)	#102.5	0-9	5EZ74	#32.5	PRE-SET DO NOT ADJUST
10D2 (Other state models)					

The pilot screw is pre-set by the factory utilizing specialized testing and adjusting procedures. The pilot screw is not adjustable as the idle circuit is "sealed" after factory adjustment. Adjusting, interfering with, improper replacement, or resetting of any of the carburetor components may adversely affect carburetor performance and cause the motorcycle to exceed the exhaust emission level limits. If persons, who are unaware of these special carburetor servicing requirements tamper with the carburetors the Suzuki dealer should restore the carburetors to their original condition or if unable to effect repairs, contact the distributors representative for further technical information and assistance.

EVAPORATIVE EMISSION CONTROL SYSTEM (Only for California model)



CANISTER HOSE ROUTING (Only for California model)



GSF400N ('92-MODEL)

CONTENTS

SPECIFICATIONS	10-1
SERVICE DATA	10-3

SPECIFICATIONS

DIMENSIONS AND DRY MASS

Overall length	2130 mm (83.9 in) . . . E16, 22, 25 2090 mm (82.3 in) . . . Others
Overall width	760 mm (29.9 in) . . . E03, 28, 33 730 mm (28.7 in) . . . Others
Overall height	1070 mm (42.1 in) . . . E03, 28, 33 1060 mm (41.7 in) . . . Others
Wheelbase	1430 mm (56.3 in)
Ground clearance	155 mm (6.1 in)
Seat height	790 mm (31.1 in)
Dry mass	168 kg (370 lbs) . . . E22 165 kg (364 lbs) . . . Others

ENGINE

Type	Four-stroke, water-cooled, DOHC, TSCC
Valve clearance	IN : 0.10 – 0.15 mm (0.004 – 0.006 in) EX: 0.15 – 0.20 mm (0.006 – 0.008 in)
Number of cylinders	4
Bore	56.0 mm (2.20 in)
Stroke	40.4 mm (1.59 in)
Piston displacement	398 cm ³ (24.28 cu. in)
Compression ratio	11.8 : 1
Carburetor	MIKUNI BST33SS, four MIKUNI BST32SS, four . . . U.S.A. model only
Air cleaner	Polyurethane foam element
Starter system	Electric starter motor
Lubrication system	Wet sump

TRANSMISSION

Clutch	Wet multi-plate type
Transmission	6-speed constant mesh
Gearshift pattern	1-down, 5-up
Primary reduction ratio	1.954 (86/44)
Gear ratios, Low	3.363 (37/11)
2nd	2.307 (30/13)
3rd	1.750 (28/16)
4th	1.437 (23/16)
5th	1.250 (30/24)
Top	1.150 (23/20)
Final reduction ratio	3.357 (47/14)
Drive chain	DID 525V ₉ or RK 525SMOZ ₂ , 114 links

CHASSIS

Front suspension	Telescopic, coil spring, oil damped
Rear suspension	New-link suspension, coil spring, gas/oil damped, spring preload 7-way adjustable
Front suspension stroke	120 mm (4.7 in)
Rear wheel travel	120 mm (4.7 in)
Caster	64° 30'
Trail	100 mm (3.9 in)
Steering angle	30° (right & left)
Turning radius	3.2 m (10.5 ft)
Front brake	Disc brake
Rear brake	Disc brake
Front tire size	110/70-17 54H, tubeless
Rear tire size	150/70-17 69H, tubeless

ELECTRICAL

Ignition type	Fully transistorized
Ignition timing	15° B.T.D.C. below 1500 r/min
Spark plug	NGK CR8EK or NIPPON DENSO U24ETR
Battery	12V 28.8 kC (8Ah)/10HR
Generator	Three-phase A.C. generator
Fuse	25/15/10/10A
Headlight	12V 60/55W
Position light	12V 4W . . . except E03, 28, 33
Turn signal light	12V 21W
Tail/Brake light	12V 5/21W
License plate light	12V 5W
Speedometer light	12V 1.7W x 2 pcs
Tachometer light	12V 1.7W x 2 pcs
Neutral indicator light	12V 3W
High beam indicator light	12V 1.7W
Turn signal light indicator light	12V 3.4W
Oil pressure indicator light	12V 3.4W
Coolant temperature check light	12V 3.4W

CAPACITIES

Fuel tank, including reserve	14.5 L (3.8/3.2 US/Imp gal) . . . E33 only
	16.0 L (4.2/3.5 US/Imp gal) . . . Others
Reserve	3.5 L (0.9/0.8 US/Imp gal)
Engine oil, oil change	2300 ml (2.4/2.0 US/Imp qt)
with filter change	2800 ml (3.0/2.5 US/Imp qt)
overhaul	3200 ml (3.4/2.8 US/Imp qt)
Coolant (including reserve)	1900 ml (2.0/1.7 US/Imp qt)
Front fork oil (each leg)	505 ml (17.1/17.8 US/Imp oz) . . . E03, 28, 33
	495 ml (16.7/17.4 US/Imp oz) . . . Others

These specifications are subject to change without notice.

SERVICE DATA**VALVE + GUIDE**

Unit: mm (in)

ITEM		STANDARD		LIMIT
Valve diam.		IN.	22.4 (0.88)	—
		EX.	20.0 (0.79)	—
Valve lift	E-33	IN.	6.5 (0.26)	—
	The others		7.6 (0.30)	—
		EX.	7.0 (0.28)	—
Valve clearance (when cold)		IN.	0.10–0.15 (0.004–0.006)	—
		EX.	0.15–0.20 (0.006–0.008)	—
Valve guide to valve stem clearance		IN.	0.025–0.052 (0.0010–0.0020)	—
		EX.	0.040–0.067 (0.0016–0.0026)	—
Valve stem deflection		IN. & EX.	—	0.35 (0.014)
Valve guide I.D.		IN. & EX.	4.500–4.512 (0.1772–0.1776)	—
Valve stem O.D.		IN.	4.460–4.475 (0.1756–0.1762)	—
		EX.	4.445–4.460 (0.1750–0.1756)	—
Valve stem runout		IN. & EX.	—	0.05 (0.002)
Valve head thickness		IN. & EX.	—	0.5 (0.02)
Valve stem end length		IN. & EX.	—	2.7 (0.11)
Valve seat width		IN. & EX.	0.7–0.9 (0.03–0.04)	—
Valve head radial runout		IN. & EX.	—	0.03 (0.001)
Valve spring free length (IN. & EX.)		INNER	—	32.6 (1.28)
		OUTER	—	37.3 (1.47)
Valve spring tension (IN. & EX.)		INNER	6.5–7.5 kg (14.3–16.5 lbs) at length 28.6 mm (1.13 in)	—
		OUTER	8.8–10.2 kg (19.4–22.5 lbs) at length 31.6 mm (1.24 in)	—

CAMSHAFT + CYLINDER HEAD

Unit: mm (in)

ITEM		STANDARD		LIMIT
Cam height	E-33	IN.	32.530–32.570 (1.2807–1.2823)	32.230 (1.2689)
	The others		33.134–33.174 (1.3045–1.3061)	32.840 (1.2929)
		EX.	32.839–32.879 (1.2929–1.2944)	32.540 (1.2811)
Camshaft journal oil clearance		IN. & EX.	0.032–0.066 (0.0013–0.0026)	0.150 (0.0059)
Camshaft journal holder I.D.		IN. & EX.	22.012–22.025 (0.8666–0.8671)	—
Camshaft journal O.D.		IN. & EX.	21.959–21.980 (0.8645–0.8654)	—
Camshaft runout		IN. & EX.	—	0.10 (0.004)
Cam chain 20-pitch length			—	143 (5.63)
Cam chain pin (at arrow "3")			20 th pin	—
Rocker arm I.D.		IN. & EX.	12.000–12.018 (0.4724–0.4731)	—
Rocker arm shaft O.D.		IN. & EX.	11.973–11.984 (0.4714–0.4718)	—
Cylinder head distortion			—	0.20 (0.008)

CYLINDER + PISTON + PISTON RING

Unit: mm (in)

ITEM		STANDARD		LIMIT
Compression pressure			1000–1450 kPa (10–14.5 kg/cm ²) (142–206 psi)	800 kPa (8 kg/cm ²) (114 psi)
Compression pressure difference			—	200 kPa (2 kg/cm ²) (28 psi)
Piston to cylinder clearance			0.050–0.060 (0.0020–0.0024)	0.120 (0.0047)
Cylinder bore			56.000–56.015 (2.2047–2.2053)	56.080 (2.2079)
Piston diam.			55.945–55.960 (2.2026–2.2031) Measure at 10 mm (0.4 in) from the skirt end.	55.880 (2.2000)
Cylinder distortion			—	0.20 (0.008)
Piston ring free end gap	1st	R	Approx. 5.6 (0.22)	4.5 (0.18)
	2nd	RN	Approx. 5.9 (0.23)	4.7 (0.19)
Piston ring end gap	1st		0.15–0.30 (0.006–0.012)	0.5 (0.02)
	2nd		0.30–0.45 (0.012–0.018)	0.5 (0.02)

ITEM	STANDARD		LIMIT
Piston ring to groove clearance	1st	—	0.180 (0.0071)
	2nd	—	0.150 (0.0059)
Piston ring groove width	1st	0.81–0.83 (0.032–0.033)	—
	2nd	0.81–0.83 (0.032–0.033)	—
	Oil	1.51–1.53 (0.059–0.060)	—
Piston ring thickness	1st	0.77–0.79 (0.030–0.031)	—
	2nd	0.77–0.79 (0.030–0.031)	—
Piston pin bore	16.002–16.008 (0.6300–0.6302)		16.030 (0.6311)
Piston pin O.D.	15.995–16.000 (0.6297–0.6299)		15.980 (0.6291)

CONROD + CRANKSHAFT

Unit: mm (in)

ITEM	STANDARD		LIMIT
Conrod small end I.D.	16.010–16.018 (0.6303–0.6306)		16.040 (0.6315)
Conrod big end side clearance	0.10–0.20 (0.004–0.008)		0.30 (0.012)
Conrod big end width	16.95–17.00 (0.667–0.669)		—
Crank pin width	17.10–17.15 (0.673–0.675)		—
Conrod big end oil clearance	0.024–0.048 (0.0009–0.0019)		0.080 (0.0031)
Crank pin O.D.	29.976–30.000 (1.1802–1.1811)		—
Crankshaft journal oil clearance	0.012–0.036 (0.0005–0.0014)		0.080 (0.0031)
Crankshaft journal O.D.	31.976–32.000 (1.2589–1.2598)		—
Crankshaft thrust bearing thickness	Left side	2.350–2.500 (0.0925–0.0984)	—
	Right side	2.425–2.450 (0.0955–0.0965)	—
Crankshaft thrust clearance	0.045–0.100 (0.0018–0.0039)		—
Crankshaft runout	—		0.05 (0.002)

OIL PUMP

ITEM	STANDARD	LIMIT
Oil pump reduction ratio	2.084 (86/44 x 32/30)	—
Oil pressure (at 60°C, 140°F)	Above 250 kPa (2.5 kg/cm ² , 36 psi) Below 600 kPa (6.0 kg/cm ² , 85 psi) at 3 000 r/min.	—

CLUTCH

Unit: mm (in)

ITEM	STANDARD	LIMIT
Clutch cable play	4 (0.16)	—
Clutch release screw	¼ – ½ turn back	—
Drive plate thickness	2.90 – 3.10 (0.114 – 0.122)	2.60 (0.102)
Drive plate claw width	11.8 – 12.0 (0.46 – 0.47)	11.0 (0.43)
Driven plate distortion	—	0.10 (0.004)
Clutch spring free length	—	31.0 (1.22)

THERMOSTAT + RADIATOR + FAN

ITEM	STANDARD	LIMIT	
Thermostat valve opening temperature	74.5 – 78.5°C (166.1 – 173.3°F)	—	
Thermostat valve lift	Over 7 mm (0.28 in) at 90°C (194°F)	—	
Radiator cap valve opening pressure	110 kPa (1.1 kg/cm ² , 15.6 psi)	—	
Cooling fan thermo-switch operating temperature	ON	Approx. 95°C (203 °F)	—
	OFF	Approx. 88°C (190.4 °F)	—
Water thermo-switch operating temperature	ON	Approx. 117°C (243°F)	—
	OFF	Approx. 110°C (230°F)	—

TRANSMISSION + DRIVE CHAIN

Unit: mm (in) Except ratio

ITEM	STANDARD	LIMIT	
Primary reduction ratio	1.954 (86/44)	—	
Final reduction ratio	3.357 (47/14)	—	
Gear ratios	Low	3.363 (37/11)	—
	2nd	2.307 (30/13)	—
	3rd	1.750 (28/16)	—
	4th	1.437 (23/16)	—
	5th	1.250 (30/24)	—
	Top	1.150 (23/20)	—
Shift fork to groove clearance	No. 1, No.2 & No.3	0.10 – 0.30 (0.004 – 0.012)	0.50 (0.020)
Shift fork groove width	No. 1, No.2 & No.3	5.5 – 5.6 (0.217 – 0.220)	—

ITEM	STANDARD		LIMIT
	No.1, No.2 & No.3	5.3—5.4 (0.209—0.213)	
Shift fork thickness			—
Countershaft length (Low to 2nd)	113.1—113.2 (4.453—4.457)		—
Drive chain	Type	D.I.D.: DID525V ₉ TAKASAGO: RK525SMOZ ₂	—
	Links	114	—
	20-pitch length	—	319.4 (12.57)
Drive chain slack	25—35 (1.0—1.4)		—
Gearshift lever height	45 (1.8)		—

CARBURETOR

ITEM	SPECIFICATION	
	E-03	E-33
Carburetor type	MIKUNI BST32SS	←
Bore size	32 mm	←
I.D. No	10D2	10D4
Idle r/min.	1 400 ± 50 r/min.	←
Float height	14.6 ± 1.0 mm	←
Main jet (M.J.)	# 102.5	←
Main air jet (M.A.J.)	0.6 mm	←
Jet needle (J.N.)	5EZ74	←
Needle jet (N.J.)	0-9	←
Throttle valve (Th.V.)	# 130	←
Pilot jet (P.J.)	# 32.5	←
By-pass (B.P.)	#10.8, #20.8, #30.8 mm	←
Pilot outlet (P.O.)	0.8 mm	0.9 mm
Valve seat (V.S.)	2.0 mm	←
Starter jet (G.S.)	# 32.5	←
Pilot screw (P.S.)	PRE-SET	←
Throttle cable play	0.5—1.0 mm (0.02—0.04 in)	←

ITEM	SPECIFICATION		
	E-02,04,16,21,25,28, 34,53	E-24	E-22
Carburetor type	BST33SS	←	←
Bore size	33 mm	←	←
I.D. No.	10D1	10D3	10D5
Idle r/min.	1 300 ± 100 r/min	←	1 400 ± 50 r/min
Float height	14.6 ± 1.0 mm	←	←
Main jet (M.J.)	# 100	←	←
Main air jet (M.A.J.)	0.6 mm	←	←
Jet needle (J.N.)	5EZ67-3rd	←	←
Needle jet (N.J.)	P-0	←	←
Throttle valve (Th.V.)	# 130	←	←
Pilot jet (P.J.)	# 32.5	←	←
By-pass (B.P.)	#10.8, #20.8, #30.8 mm	←	←

ITEM	SPECIFICATION		
	E-02,04,16,21,25,28, 34,53	E-24	E-22
Pilot outlet (P.O.)	0.7 mm	←	←
Valve seat (V.S.)	2.0 mm	←	←
Starter jet (G.S.)	# 32.5	←	←
Pilot screw (P.S.)	PRE-SET (1½ turns back)	←	PRE-SET (1¼ turns back)
Throttle cable play	0.5–1.0 mm (0.02–0.04 in)	←	←

ELECTRICAL

Unit: mm (in)

ITEM	SPECIFICATION		NOTE
Ignition timing	7° B.T.D.C. below 1 500 r/min.		For California model
	15° B.T.D.C. below 1 500 r/min.		For the Other model
Firing order	1·2·4·3		
Spark plug	Type	ND.: U24ETR N.G.K.: CR8EK	
	Gap	0.6–0.7 (0.02–0.03)	
Spark performance	Over 8 (0.3) at 1 atm.		
Signal coil resistance	80–120 Ω		Tester range: x 10 Ω
Ignition coil resistance	Primary	⊕ tap—⊖ tap 2.5–3.8 Ω	Tester range: x 1 Ω
	Secondary	Plug cap—Plug cap 30–50 k Ω	Tester range: x 1 k Ω
Generator no-load voltage	More than 70 V (AC) at 5 000 r/min.		When cold
Regulated voltage	13.5–15.5 V at 5 000 r/min.		
Starter motor brush length	Limit: 3.5 (0.14)		
Commutator under-cut	Limit: 0.5 (0.02)		
Starter relay resistance	3–5 Ω		
Battery	Type designation	YTX9-BS	
	Capacity	12V 28.8 kC (8 Ah)/10 HR	
	Standard electrolyte S.G.	1.32 at 20°C (68°F)	
Fuse size	Headlight	15 A	
	Signal	10 A	
	Ignition	10 A	
	Main	25 A	

WATTAGE

Unit: W

ITEM	SPECIFICATION	
Headlight	HI	60
	LO	55
Parking or position light	4 (Except E-03,28 and 33)	
Tail/Brake light	5/21	
Turn signal light	21	
Tachometer light	1.7 x 2pcs	
Speedometer light	1.7 x 2pcs	

ITEM	SPECIFICATION
Water temp. check light	3.4
Turn signal indicator light	3.4
High beam indicator light	1.7
Neutral indicator light	3
Oil pressure indicator light	3.4
License light	5

BRAKE + WHEEL

Unit: mm (in)

ITEM	STANDARD		LIMIT
Rear brake pedal height	45 (1.8)		—
Brake disc thickness	Front	4.5 ± 0.2 (0.18 ± 0.008)	4.0 (0.16)
	Rear	6.0 ± 0.2 (0.24 ± 0.008)	5.5 (0.22)
Brake disc runout	—		0.30 (0.012)
Master cylinder bore	Front	12.700 – 12.743 (0.5000 – 0.5017)	—
	Rear	12.700 – 12.743 (0.5000 – 0.5017)	—
Master cylinder piston diam.	Front	12.657 – 12.684 (0.4983 – 0.4994)	—
	Rear	12.657 – 12.684 (0.4983 – 0.4994)	—
Brake caliper cylinder bore	Front	27.000 – 27.076 (1.0630 – 1.0660)	—
		33.960 – 34.036 (1.3370 – 1.3400)	—
	Rear	38.180 – 38.256 (1.5031 – 1.5061)	—
Brake caliper piston diam.	Front	26.920 – 26.970 (1.0598 – 1.0618)	—
		33.884 – 33.934 (1.3340 – 1.3360)	—
	Rear	38.098 – 38.148 (1.4999 – 1.5019)	—
Wheel rim runout	Axial	—	2.0 (0.08)
	Radial	—	2.0 (0.08)
Wheel axle runout	Front	—	0.25 (0.010)
	Rear	—	0.25 (0.010)
Tire size	Front	110/70-17 54H	—
	Rear	150/70-17 69H	—
Tire tread depth	Front	—	1.6 (0.06)
	Rear	—	2.0 (0.08)

SUSPENSION

Unit: mm (in)

ITEM	STANDARD	LIMIT	NOTE
Front fork stroke	120 (4.72)	—	
Front fork spring free length	—	262 (10.3)	
Front fork oil level	95 (3.74)	—	For E-03,28 and 33 models
	105 (4.13)	—	For the other models
Rear shock absorber spring adjuster	4/7	—	
Rear wheel travel	120 (4.72)	—	
Swingarm pivot shaft runout	—	0.3 (0.01)	

TIRE PRESSURE

COLD INFLATION TIRE PRESSURE	SOLO RIDING			DUAL RIDING		
	kPa	kg/cm ²	psi	kPa	kg/cm ²	psi
FRONT	200	2.00	29	200	2.00	29
REAR	225	2.25	33	250	2.50	36

FUEL + OIL + COOLANT

ITEM	SPECIFICATION	NOTE
Fuel type	Use only unleaded gasoline of at least 87 pump octane ($\frac{R+M}{2}$) or 91 octane or higher rated by the research method. Gasoline containing MTBE (Methyl Tertiary Butyl Ether), less than 10% ethanol, or less than 5% methanol with appropriate cosolvents and corrosion inhibitor is permissible.	For U.S.A. model
	Use only unleaded gasoline of at least 87 pump octane ($\frac{R+M}{2}$ method) or 91 octane or higher rated by the Reserch Method.	For Canada model
	Gasoline used should be graded 85-95 octane or higher. An unleaded gasoline is recommended.	For the other model
Fuel tank including reserve	14.5 L (3.8/3.2 US/lmp gal)	For California model
	16 L (4.2/3.5 US/lmp gal)	For the other models
	reserve 3.5 L (0.9/0.8 US/lmp gal)	
Engine oil type	SAE 10W/40, API SE or SF	
Engine oil capacity	Change 2 300 ml (2.4/2.0 US/lmp qt)	
	Filter change 2 800 ml (3.0/2.5 US/lmp qt)	
	Overhaul 3 200 ml (3.4/2.8 US/lmp qt)	

ITEM	SPECIFICATION	NOTE
Front fork oil type	Fork oil # 10	
Front fork oil capacity (each leg)	505 ml (17.1/17.8 US/lmp oz)	For E-03,28 and 33 models
	495 ml (16.7/17.4 US/lmp oz)	For the other models
Brake fluid type	DOT3 or DOT4	
Coolant type	Use an anti-freeze/coolant compatible with aluminum radiator, mixed with distilled water only, at the ratio of 50:50.	
Coolant including reserve	1 900 ml (2.0/1.7 US/lmp qt)	

GSF400P ('93-MODEL)

FOREWORD

This section describes service data, service specifications and servicing procedures which differ from those of the GSF400N ('92-model).

NOTE:

- Any differences between GSF400N ('92-model) and GSF400P ('93-model) in specifications and service data are clearly indicated with the asterisk marks (*).
- Please refer to the sections 1 through 10 for details which are not given in this section.

CONTENTS

SPECIFICATIONS	11- 1
SERVICE DATA	11- 3
VALVE	11-12
ENGINE MOUNTING	11-12
TIGHTENING TORQUE	11-13
WIRING DIAGRAM	11-14

SPECIFICATIONS

DIMENSIONS AND DRY MASS

Overall length	2130 mm (83.9 in) . . . E16, 22, 25
	2090 mm (82.3 in) . . . Others
Overall width	760 mm (29.9 in) . . . E03, 28, 33
	730 mm (28.7 in) . . . Others
Overall height	1070 mm (42.1 in) . . . E03, 28, 33
	1060 mm (41.7 in) . . . Others
Wheelbase	1430 mm (56.3 in)
Ground clearance	155 mm (6.1 in)
Seat height	790 mm (31.1 in)
Dry mass	168 kg (370 lbs) . . . E22
	165 kg (364 lbs) . . . Others

ENGINE

Type	Four-stroke, water-cooled, DOHC, TSCC
Valve clearance	*IN : 0.13 – 0.18 mm (0.005 – 0.007 in)
	*EX: 0.20 – 0.25 mm (0.008 – 0.010 in)
Number of cylinders	4
Bore	56.0 mm (2.20 in)
Stroke	40.4 mm (1.59 in)
Piston displacement	398 cm ³ (24.28 cu. in)
Compression ratio	11.8 : 1
Carburetor	MIKUNI BST33SS, four
	MIKUNI BST32SS, four . . . U.S.A. model only
Air cleaner	Polyurethane foam element
Starter system	Electric starter motor
Lubrication system	Wet sump

TRANSMISSION

Clutch	Wet multi-plate type
Transmission	6-speed constant mesh
Gearshift pattern	1-down, 5-up
Primary reduction ratio	1.954 (86/44)
Gear ratios, Low	3.363 (37/11)
2nd	2.307 (30/13)
3rd	1.750 (28/16)
4th	1.437 (23/16)
5th	1.250 (30/24)
Top	* 1.136 (25/22)
Final reduction ratio	* 3.285 (46/14)
Drive chain	DID 525V ₉ or RK 525SMOZ ₂ , 114 links

Asterisk mark (*) indicates the new GSF400P model specifications.

CHASSIS

Front suspension	Telescopic, coil spring, oil damped
Rear suspension	New-link suspension, coil spring, gas/oil damped, spring preload 7-way adjustable
Front suspension stroke	120 mm (4.7 in)
Rear wheel travel	120 mm (4.7 in)
Caster	64° 30'
Trail	100 mm (3.9 in)
Steering angle	30° (right & left)
Turning radius	3.2 m (10.5 ft)
Front brake	Disc brake
Rear brake	Disc brake
Front tire size	110/70-17 54H, tubeless
Rear tire size	150/70-17 69H, tubeless

ELECTRICAL

Ignition type	Fully transistorized
Ignition timing	15° B.T.D.C. below 1500 r/min
Spark plug	*NGK CR9EK or NIPPON DENSO U27ETR
Battery	12V 28.8 kC (8Ah)/10HR
Generator	Three-phase A.C. generator
Fuse	25/15/10/10A
Headlight	12V 60/55W
Position light	12V 4W . . . except E03, 28, 33
Turn signal light	12V 21W
Tail/Brake light	12V 5/21W
License plate light	12V 5W
Speedometer light	12V 1.7W x 2 pcs
Tachometer light	12V 1.7W x 2 pcs
Neutral indicator light	12V 3W
High beam indicator light	12V 1.7W
Turn signal light indicator light	12V 3.4W
Oil pressure indicator light	12V 3.4W
Coolant temperature check light	12V 3.4W

CAPACITIES

Fuel tank, including reserve	14.5 L (3.8/3.2 US/Imp gal) . . . E33 only 16.0 L (4.2/3.5 US/Imp gal) . . . Others
Reserve	3.5 L (0.9/0.8 US/Imp gal)
Engine oil, oil change	2300 ml (2.4/2.0 US/Imp qt)
with filter change	2800 ml (3.0/2.5 US/Imp qt)
overhaul	3200 ml (3.4/2.8 US/Imp qt)
Coolant (including reserve)	1900 ml (2.0/1.7 US/Imp qt)
Front fork oil (each leg)	505 ml (17.1/17.8 US/Imp oz) . . . E03, 28, 33 495 ml (16.7/17.4 US/Imp oz) . . . Others

Asterisk mark (*) indicates the new GSF400P model specifications.
These specifications are subject to change without notice.

SERVICE DATA

VALVE + GUIDE

Unit: mm (in)

ITEM	STANDARD		LIMIT
Valve diam.	IN.	22.4 (0.88)	—
	EX.	20.0 (0.79)	—
Valve lift	IN.	* 6.2 (0.24)	—
	EX.	* 6.2 (0.24)	—
Valve clearance (when cold)	IN.	* 0.13–0.18 (0.005–0.007)	—
	EX.	* 0.20–0.25 (0.008–0.010)	—
Valve guide to valve stem clearance	IN.	* 0.020–0.047 (0.0008–0.0019)	—
	EX.	0.040–0.067 (0.0016–0.0026)	—
Valve stem deflection	IN. & EX.	—	0.35 (0.014)
Valve guide I.D.	IN. & EX.	4.500–4.512 (0.1772–0.1776)	—
Valve stem O.D.	IN.	* 4.465–4.480 (0.1758–0.1764)	—
	EX.	4.445–4.460 (0.1750–0.1756)	—
Valve stem runout	IN. & EX.	—	0.05 (0.002)
Valve head thickness	IN. & EX.	—	0.5 (0.02)
Valve stem end length	IN. & EX.	—	2.7 (0.11)
Valve seat width	IN. & EX.	0.7–0.9 (0.03–0.04)	—
Valve head radial runout	IN. & EX.	—	0.03 (0.001)
Valve spring free length (IN. & EX.)	INNER	—	32.6 (1.28)
	OUTER	—	37.3 (1.47)
Valve spring tension (IN. & EX.)	INNER	6.5–7.5 kg (14.3–16.5 lbs) at length 28.6 mm (1.13 in)	—
	OUTER	8.8–10.2 kg (19.4–22.5 lbs) at length 31.6 mm (1.24 in)	—

Asterisk mark (*) indicates the new GSF400P model specifications.

CAMSHAFT + CYLINDER HEAD

Unit: mm (in)

ITEM	STANDARD		LIMIT
Cam height	IN.	* 32.222 – 32.278 (1.2686 – 1.2708)	* 31.930 (1.2571)
	EX.	* 32.372 – 32.428 (1.2745 – 1.2767)	* 32.030 (1.2610)
Camshaft journal oil clearance	IN. & EX.	0.032 – 0.066 (0.0013 – 0.0026)	0.150 (0.0059)
Camshaft journal holder I.D.	IN. & EX.	22.012 – 22.025 (0.8666 – 0.8671)	—
Camshaft journal O.D.	IN. & EX.	21.959 – 21.980 (0.8645 – 0.8654)	—
Camshaft runout	IN. & EX.	—	0.10 (0.004)
Cam chain 20-pitch length	—		143 (5.63)
Cam chain pin (at arrow "3")	20 th pin		—
Rocker arm I.D.	IN. & EX.	12.000 – 12.018 (0.4724 – 0.4731)	—
Rocker arm shaft O.D.	IN. & EX.	11.973 – 11.984 (0.4714 – 0.4718)	—
Cylinder head distortion	—		0.20 (0.008)

CYLINDER + PISTON + PISTON RING

Unit: mm (in)

ITEM	STANDARD		LIMIT
Compression pressure	1000 – 1450 kPa (10 – 14.5 kg/cm ²) (142 – 206 psi)		800 kPa (8 kg/cm ²) (114 psi)
Compression pressure difference	—		200 kPa (2 kg/cm ²) (28 psi)
Piston to cylinder clearance	0.050 – 0.060 (0.0020 – 0.0024)		0.120 (0.0047)
Cylinder bore	56.000 – 56.015 (2.2047 – 2.2053)		56.080 (2.2079)
Piston diam.	55.945 – 55.960 (2.2026 – 2.2031) Measure at 10 mm (0.4 in) from the skirt end.		55.880 (2.2000)
Cylinder distortion	—		0.20 (0.008)
Piston ring free end gap	1st	R	Approx. 5.6 (0.22)
	2nd	RN	Approx. 5.9 (0.23)
Piston ring end gap	1st	0.15 – 0.30 (0.006 – 0.012)	
	2nd	0.30 – 0.45 (0.012 – 0.018)	

Asterisk mark (*) indicates the new GSF400P model specifications.

ITEM	STANDARD		LIMIT
Piston ring to groove clearance	1st	—	0.180 (0.0071)
	2nd	—	0.150 (0.0059)
Piston ring groove width	1st	0.81–0.83 (0.032–0.033)	—
	2nd	0.81–0.83 (0.032–0.033)	—
	Oil	1.51–1.53 (0.059–0.060)	—
Piston ring thickness	1st	0.77–0.79 (0.030–0.031)	—
	2nd	0.77–0.79 (0.030–0.031)	—
Piston pin bore	16.002–16.008 (0.6300–0.6302)		16.030 (0.6311)
Piston pin O.D.	15.995–16.000 (0.6297–0.6299)		15.980 (0.6291)

CONROD + CRANKSHAFT

Unit: mm (in)

ITEM	STANDARD		LIMIT
Conrod small end I.D.	16.010–16.018 (0.6303–0.6306)		16.040 (0.6315)
Conrod big end side clearance	0.10–0.20 (0.004–0.008)		0.30 (0.012)
Conrod big end width	16.95–17.00 (0.667–0.669)		—
Crank pin width	17.10–17.15 (0.673–0.675)		—
Conrod big end oil clearance	0.024–0.048 (0.0009–0.0019)		0.080 (0.0031)
Crank pin O.D.	29.976–30.000 (1.1802–1.1811)		—
Crankshaft journal oil clearance	0.012–0.036 (0.0005–0.0014)		0.080 (0.0031)
Crankshaft journal O.D.	31.976–32.000 (1.2589–1.2598)		—
Crankshaft thrust bearing thickness	Left side	2.350–2.500 (0.0925–0.0984)	—
	Right side	2.425–2.450 (0.0955–0.0965)	—
Crankshaft thrust clearance	0.045–0.100 (0.0018–0.0039)		—
Crankshaft runout	—		0.05 (0.002)

OIL PUMP

ITEM	STANDARD	LIMIT
Oil pump reduction ratio	2.084 (86/44 x 32/30)	—
Oil pressure (at 60°C, 140°F)	Above 250 kPa (2.5 kg/cm ² , 36 psi) Below 600 kPa (6.0 kg/cm ² , 85 psi) at 3 000 r/min.	—

CLUTCH

Unit: mm (in)

ITEM	STANDARD	LIMIT
Clutch cable play	4 (0.16)	—
Clutch release screw	¼ – ½ turn back	—
Drive plate thickness	2.90 – 3.10 (0.114 – 0.122)	2.60 (0.102)
Drive plate claw width	11.8 – 12.0 (0.46 – 0.47)	11.0 (0.43)
Driven plate distortion	—	0.10 (0.004)
Clutch spring free length	—	31.0 (1.22)

THERMOSTAT + RADIATOR + FAN

ITEM	STANDARD	LIMIT	
Thermostat valve opening temperature	74.5 – 78.5°C (166.1 – 173.3°F)	—	
Thermostat valve lift	Over 7 mm (0.28 in) at 90°C (194°F)	—	
Radiator cap valve opening pressure	110 kPa (1.1 kg/cm ² , 15.6 psi)	—	
Cooling fan thermo-switch operating temperature	ON	Approx. 95°C (203 °F)	—
	OFF	Approx. 88°C (190.4 °F)	—
Water thermo-switch operating temperature	ON	Approx. 117°C (243°F)	—
	OFF	Approx. 110°C (230°F)	—

TRANSMISSION + DRIVE CHAIN

Unit: mm (in) Except ratio

ITEM	STANDARD	LIMIT	
Primary reduction ratio	1.954 (86/44)	—	
Final reduction ratio	*3.285 (46/14)	—	
Gear ratios	Low	3.363 (37/11)	—
	2nd	2.307 (30/13)	—
	3rd	1.750 (28/16)	—
	4th	1.437 (23/16)	—
	5th	1.250 (30/24)	—
	Top	*1.136 (25/22)	—
Shift fork to groove clearance	No.1, No.2 & No.3	0.10 – 0.30 (0.004 – 0.012)	0.50 (0.020)
Shift fork groove width	No.1, No.2 & No.3	5.5 – 5.6 (0.217 – 0.220)	—

Asterisk mark (*) indicates the new GSF400P model specifications.

ITEM	STANDARD		LIMIT
	No. 1, No. 2 & No. 3	5.3–5.4 (0.209–0.213)	
Shift fork thickness	No. 1, No. 2 & No. 3	5.3–5.4 (0.209–0.213)	—
Countershaft length (Low to 2nd)	113.1–113.2 (4.453–4.457)		—
Drive chain	Type	D.I.D.: DID525V ₉ TAKASAGO: RK525SMOZ ₂	—
	Links	114	—
	20-pitch length	—	319.4 (12.57)
Drive chain slack	25–35 (1.0–1.4)		—
Gearshift lever height	45 (1.8)		—

CARBURETOR

ITEM	SPECIFICATION	
	E-03,30	E-33
Carburetor type	MIKUNI BST32SS	←
Bore size	32 mm	←
I.D. No.	*10D9	*10DA
Idle r/min.	1 400 ± 50 r/min.	*1 500 ± 50 r/min.
Float height	14.6 ± 1.0 mm	←
Main jet (M.J.)	# 102.5	←
Main air jet (M.A.J.)	0.6 mm	←
Jet needle (J.N.)	5EZ74	←
Needle jet (N.J.)	0-9	←
Throttle valve (Th.V.)	# 130	←
Pilot jet (P.J.)	# 32.5	←
By-pass (B.P.)	* ¹ 0.8, * ² 0.8, * ³ 0.8 mm	←
Pilot outlet (P.O.)	0.8 mm	0.9 mm
Valve seat (V.S.)	2.0 mm	←
Starter jet (G.S.)	# 32.5	*# 30
Pilot screw (P.S.)	PRE-SET	←
Throttle cable play	0.5–1.0 mm (0.02–0.04 in)	←

ITEM	SPECIFICATION	
	E-02,04,16,21,25,28,34,53	E-22
Carburetor type	BST33SS	←
Bore size	33 mm	←
I.D. No.	*10D8	*10DB
Idle r/min.	1 300 ± 100 r/min	1 400 ± 50 r/min
Float height	14.6 ± 1.0 mm	←
Main jet (M.J.)	*# 102.5	←
Main air jet (M.A.J.)	0.6 mm	←
Jet needle (J.N.)	*5EZ80-3rd	←
Needle jet (N.J.)	P-0	←
Throttle valve (Th.V.)	# 130	←
Pilot jet (P.J.)	# 32.5	←
By-pass (B.P.)	* ¹ 0.8, * ² 0.8, * ³ 0.8 mm	←

Asterisk mark (*) indicates the new GSF400P model specifications.

ITEM	SPECIFICATION	
	E-02,04,16,21,25,28,34,53	E-22
Pilot outlet (P.O.)	0.7 mm	←
Valve seat (V.S.)	2.0 mm	←
Starter jet (G.S.)	# 32.5	←
Pilot screw (P.S.)	PRE-SET (1½ turns back)	PRE-SET (1¼ turns back)
Throttle cable play	0.5–1.0 mm (0.02–0.04 in)	←

ELECTRICAL

Unit: mm (in)

ITEM	SPECIFICATION		NOTE
Ignition timing	7° B.T.D.C. at 1 500 r/min.		For California model
	15° B.T.D.C. at 1 500 r/min.		For the Other model
Firing order	1·2·4·3		
Spark plug	Type	* ND.: U27ETR * N.G.K.: CR9EK	
	Gap	0.6–0.7 (0.02–0.03)	
Spark performance	Over 8 (0.3) at 1 atm.		
Signal coil resistance	80–120 Ω		Tester range: x 10 Ω
Ignition coil resistance	Primary	⊕ tap–⊖ tap 2.5–3.8 Ω	Tester range: x 1 Ω
	Secondary	Plug cap–Plug cap 30–50 k Ω	Tester range: x 1 k Ω
Generator no-load voltage	More than 70 V (AC) at 5 000 r/min.		When cold
Regulated voltage	13.5–15.5 V at 5 000 r/min.		
Starter motor brush length	Limit: 3.5 (0.14)		
Commutator under-cut	Limit: 0.5 (0.02)		
Starter relay resistance	3–5 Ω		
Battery	Type designation	YTX9-BS	
	Capacity	12V 28.8 kC (8 Ah)/10 HR	
	Standard electrolyte S.G.	1.32 at 20°C (68°F)	
Fuse size	Headlight	15 A	
	Signal	10 A	
	Ignition	10 A	
	Main	25 A	

WATTAGE

Unit:W

ITEM	SPECIFICATION	
Headlight	HI	60
	LO	55
Parking or position light	4 (Except E-03,28 and 33)	
Tail/Brake light	5/21	
Turn signal light	21	
Tachometer light	1.7 x 2pcs	
Speedometer light	1.7 x 2pcs	

Asterisk mark (*) indicates the new GSF400P model specifications.

ITEM	SPECIFICATION
Water temp. check light	3.4
Turn signal indicator light	3.4
High beam indicator light	1.7
Neutral indicator light	3
Oil pressure indicator light	3.4
License light	5

BRAKE + WHEEL

Unit: mm (in)

ITEM	STANDARD		LIMIT
Rear brake pedal height	45 (1.8)		—
Brake disc thickness	Front	4.5 ± 0.2 (0.18 ± 0.008)	4.0 (0.16)
	Rear	6.0 ± 0.2 (0.24 ± 0.008)	5.5 (0.22)
Brake disc runout	—		0.30 (0.012)
Master cylinder bore	Front	12.700–12.743 (0.5000–0.5017)	—
	Rear	12.700–12.743 (0.5000–0.5017)	—
Master cylinder piston diam.	Front	12.657–12.684 (0.4983–0.4994)	—
	Rear	12.657–12.684 (0.4983–0.4994)	—
Brake caliper cylinder bore	Front	27.000–27.076 (1.0630–1.0660)	—
		33.960–34.036 (1.3370–1.3400)	—
	Rear	38.180–38.256 (1.5031–1.5061)	—
Brake caliper piston diam.	Front	26.920–26.970 (1.0598–1.0618)	—
		33.884–33.934 (1.3340–1.3360)	—
	Rear	38.098–38.148 (1.4999–1.5019)	—
Wheel rim runout	Axial	—	2.0 (0.08)
	Radial	—	2.0 (0.08)
Wheel axle runout	Front	—	0.25 (0.010)
	Rear	—	0.25 (0.010)
Tire size	Front	110/70-17 54H	—
	Rear	150/70-17 69H	—
Tire tread depth	Front	—	1.6 (0.06)
	Rear	—	2.0 (0.08)

SUSPENSION

Unit: mm (in)

ITEM	STANDARD	LIMIT	NOTE
Front fork stroke	120 (4.72)	—	
Front fork spring free length	—	262 (10.3)	
Front fork oil level	95 (3.74)	—	For E-03,28 and 33 models
	105 (4.13)	—	For the other models
Rear shock absorber spring adjuster	4/7	—	
Rear wheel travel	120 (4.72)	—	
Swingarm pivot shaft runout	—	0.3 (0.01)	

TIRE PRESSURE

COLD INFLATION TIRE PRESSURE	SOLO RIDING			DUAL RIDING		
	kPa	kg/cm ²	psi	kPa	kg/cm ²	psi
FRONT	200	2.00	29	200	2.00	29
REAR	225	2.25	33	250	2.50	36

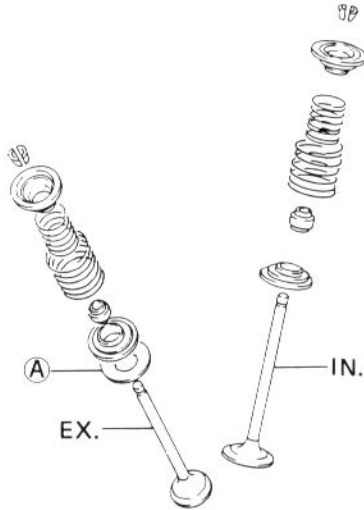
FUEL + OIL + COOLANT

ITEM	SPECIFICATION	NOTE
Fuel type	Use only unleaded gasoline of at least 87 pump octane ($\frac{R+M}{2}$) or 91 octane or higher rated by the research method. Gasoline containing MTBE (Methyl Tertiary Butyl Ether), less than 10% ethanol, or less than 5% methanol with appropriate cosolvents and corrosion inhibitor is permissible.	For U.S.A. model
	Use only unleaded gasoline of at least 87 pump octane ($\frac{R+M}{2}$ method) or 91 octane or higher rated by the Reserch Method.	For Canada model
	Gasoline used should be graded 85-95 octane or higher. An unleaded gasoline is recommended.	For the other model
Fuel tank including reserve	14.5 L (3.8/3.2 US/Imp gal)	For California model
	16 L (4.2/3.5 US/Imp gal)	For the other models
	reserve 3.5 L (0.9/0.8 US/Imp gal)	
Engine oil type	SAE 10W/40, API SE or SF	
Engine oil capacity	Change 2 300 ml (2.4/2.0 US/Imp qt)	
	Filter change 2 800 ml (3.0/2.5 US/Imp qt)	
	Overhaul 3 200 ml (3.4/2.8 US/Imp qt)	

11-11 GSF400P ('93-MODEL)

ITEM	SPECIFICATION	NOTE
Front fork oil type	Fork oil # 10	
Front fork oil capacity (each leg)	505 ml (17.1/17.8 US/Imp oz)	For E-03,28 and 33 models
	495 ml (16.7/17.4 US/Imp oz)	For the other models
Brake fluid type	DOT3 or DOT4	
Coolant type	Use an anti-freeze/coolant compatible with aluminum radiator, mixed with distilled water only, at the ratio of 50:50.	
Coolant including reserve	1 900 ml (2.0/1.7 US/Imp qt)	

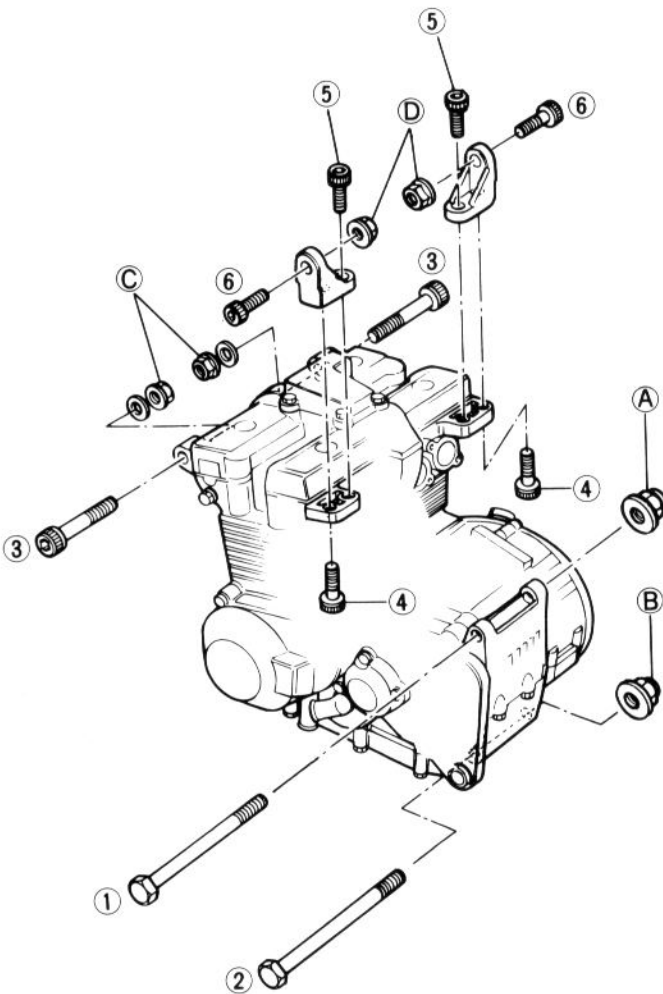
VALVE



('93-MODEL ONLY)

The exhaust valve spring lower seat shim (A) has been eliminated from '93-model.

ENGINE MOUNTING



BOLT LENGTH

①	135 mm (5.3 in)
②	145 mm (5.7 in)
③	70 mm (2.8 in)
④	*25 mm (1.0 in)
⑤	25 mm (1.0 in)
⑥	30 mm (1.2 in)

Asterisk mark (*) indicates the new GSF400P model specifications.

TIGHTENING TORQUE

ITEM	N·m	kg·m	lb·ft
(A) (B) (C)	60 – 72	6.0 – 7.2	43.5 – 52.0
(4) (5) (D)	22 – 30	2.2 – 3.0	16.0 – 21.5

TIGHTENING TORQUE

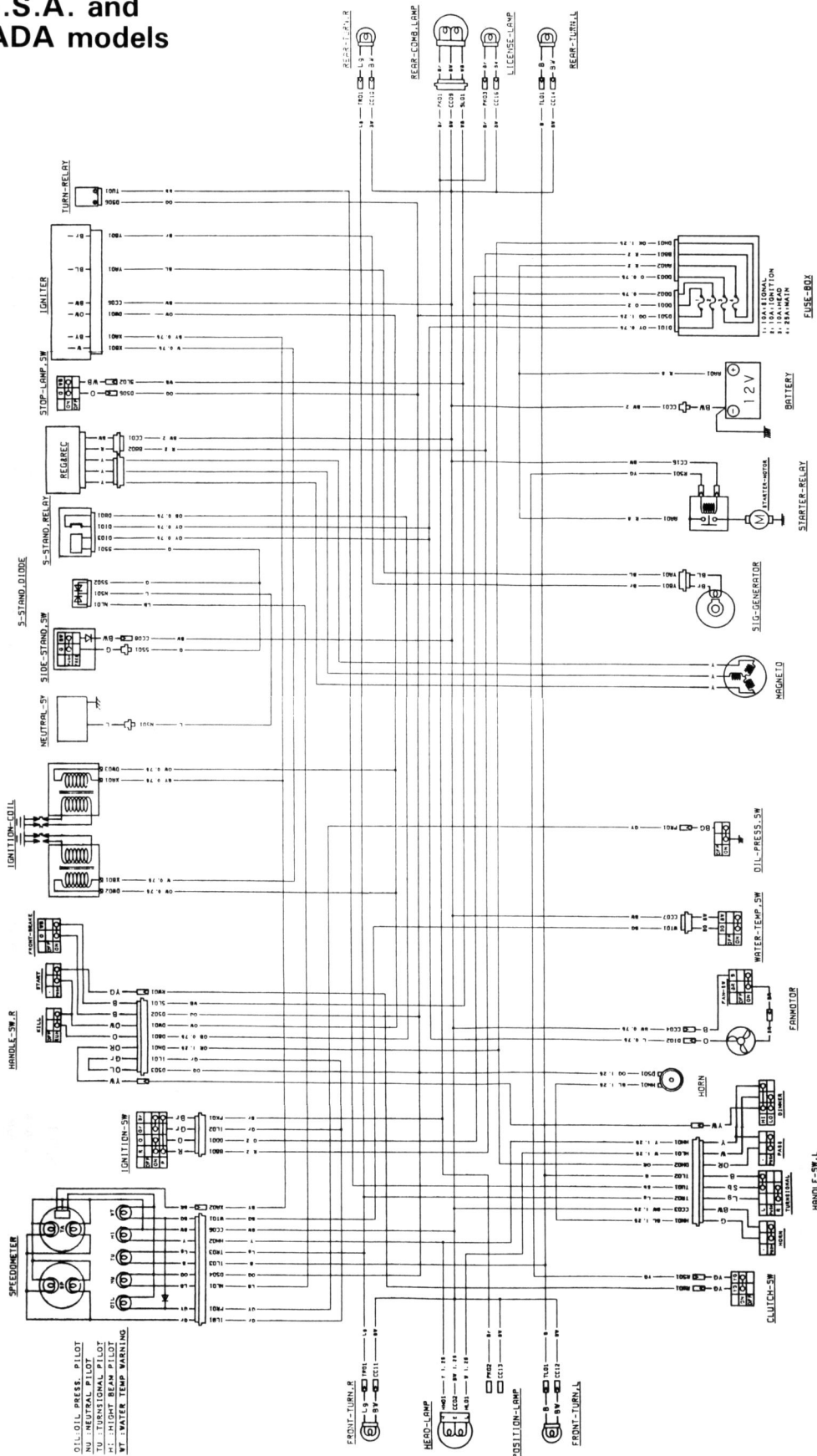
CHASSIS

ITEM		N·m	kg·m	lb·ft
Steering stem head nut		50 – 80	5.0 – 8.0	36.0 – 58.0
Front fork upper clamp bolt		40 – 60	4.0 – 6.0	29.0 – 43.5
Front fork lower clamp bolt		*22 – 35	*2.2 – 3.5	*16.0 – 25.5
Front axle shaft		50 – 80	5.0 – 8.0	36.0 – 58.0
Front axle pinch bolt		18 – 28	1.8 – 2.8	13.0 – 20.0
Handlebar clamp bolt		18 – 28	1.8 – 2.8	13.0 – 20.0
Front footrest bracket mounting bolt		18 – 28	1.8 – 2.9	13.0 – 20.0
Front brake master cylinder mounting bolt		5 – 8	0.5 – 0.8	3.5 – 6.0
Front brake caliper mounting bolt		30 – 48	3.0 – 4.8	21.5 – 35.0
Front brake caliper housing bolt		30 – 36	3.0 – 3.6	21.5 – 26.0
Brake hose union bolt		15 – 20	1.5 – 2.0	11.0 – 14.5
Air bleeder valve		6 – 9	0.6 – 0.9	4.5 – 6.5
Front and rear disc bolt		18 – 28	1.8 – 2.8	13.0 – 20.0
Swingarm pivot nut		85 – 115	8.5 – 11.5	61.5 – 83.0
Rear shock absorber upper/lower mounting nut		48 – 72	4.8 – 7.2	34.5 – 52.0
Rear cushion lever mounting nut		84 – 120	8.4 – 12.0	60.5 – 87.0
Rear cushion lever rod mounting nut (Upper & Lower)		84 – 120	8.4 – 12.0	60.5 – 87.0
Rear brake caliper mounting bolt		20 – 31	2.0 – 3.1	14.5 – 22.5
Rear brake caliper housing bolt		30 – 36	3.0 – 3.6	21.5 – 26.0
Torque link nut (Front & Rear)	Normal nut with cotter pin	22 – 35	2.2 – 3.5	16.0 – 25.5
	Self-lock nut	25 – 39	2.5 – 3.9	18.0 – 28.0
Rear brake pedal boss nut		35 – 55	3.5 – 5.5	25.5 – 40.0
Rear brake push rod lock nut		15 – 20	1.5 – 2.0	11.0 – 14.5
Rear brake master cylinder mounting bolt		8 – 12	0.8 – 1.2	6.0 – 8.5
Rear axle nut	Normal nut with cotter pin	50 – 80	5.0 – 8.0	36.0 – 58.0
	Self-lock nut	55 – 88	5.5 – 8.8	40.0 – 63.5
Rear sprocket nut		40 – 60	4.0 – 6.0	29.0 – 43.5

Asterisk mark (*) indicates the new GSF400P model specifications.

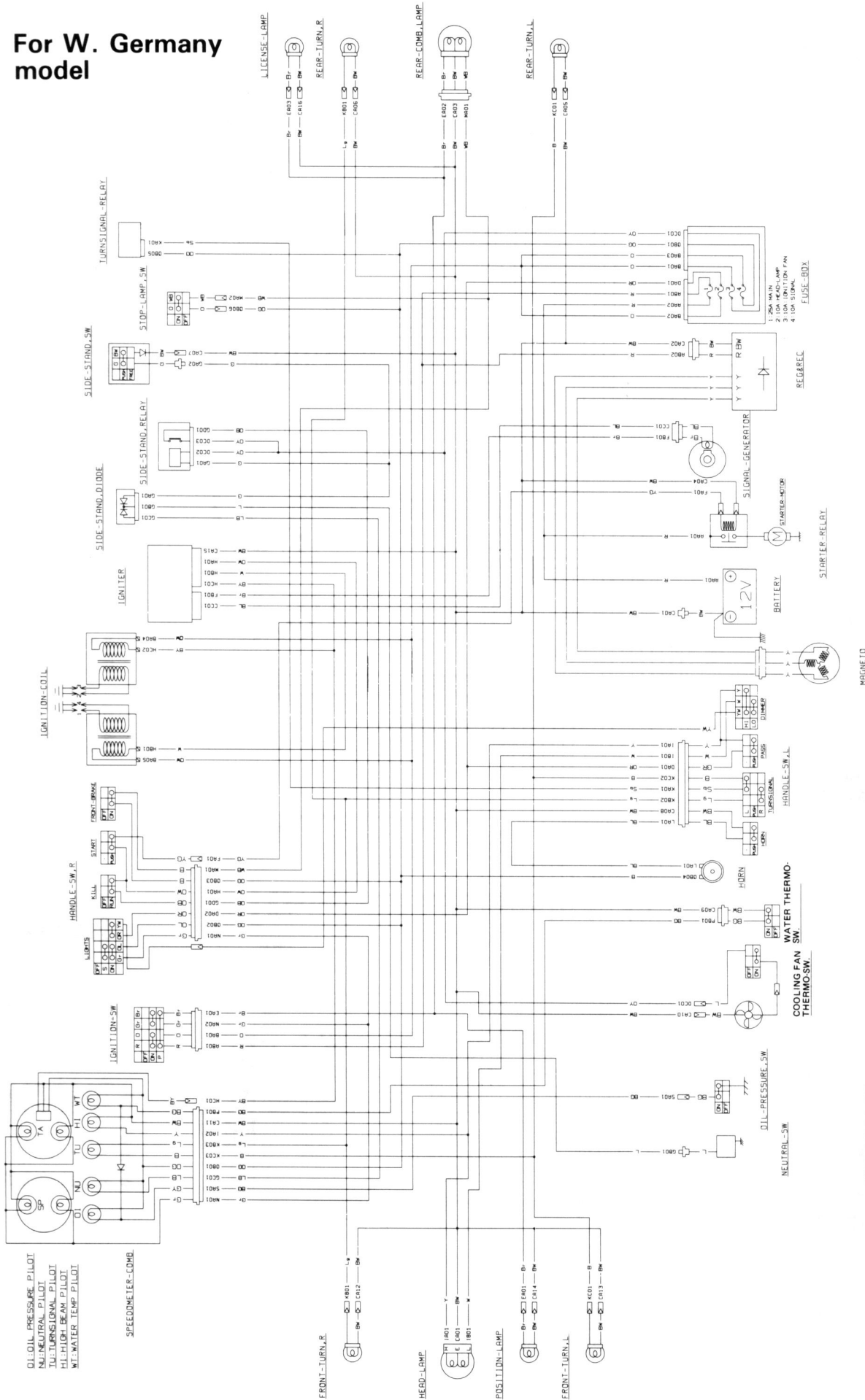
WIRING DIAGRAM

For U.S.A. and CANADA models



WIRE COLOR	WIRE COLOR	WIRE COLOR	
B	Black	O/R	Orange with Red tracer
L	Blue	O/W	Orange with White tracer
Br	Brown	O/Y	Orange with Yellow tracer
G	Green	R/W	Red with White tracer
Gr	Gray	W/B	White with Black tracer
Sb	Light blue	Y/G	Yellow with Green tracer
Lg	Light green	Y/W	Yellow with White tracer
O	Orange	B/W	Black with White tracer
R	Red	B/Y	Black with Yellow tracer
W	White	L/B	Blue with Black tracer
Y	Yellow	G/Y	Green with Yellow tracer
B/Br	Black with Brown tracer	O/B	Orange with Black tracer
B/G	Black with Green tracer	O/Bl	Orange with Blue tracer
B/L	Black with Light blue tracer	O/G	Orange with Green tracer

For W. Germany model



WIRE COLOR

B	Black	O/R	Orange with Red tracer
L	Blue	O/W	Orange with White tracer
Br	Brown	O/Y	Orange with Yellow tracer
G	Green	R/W	Red with White tracer
Gr	Gray	R/W	Red with White tracer
Sb	Light blue	W/B	White with Black tracer
Lg	Light green	Y/G	Yellow with Green tracer
		Y/W	Yellow with White tracer
		B/W	Black with White tracer
		B/Y	Black with Yellow tracer
		L/B	Blue with Black tracer
		G/Y	Green with Yellow tracer
		O/B	Orange with Black tracer
		O/Bl	Orange with Blue tracer
		O/G	Orange with Green tracer
		O	Orange
		R	Red
		W	White
		Y	Yellow
		B/Br	Black with Brown tracer
		B/G	Black with Green tracer
		B/L	Black with Blue tracer

GSF400VV ('97-MODEL)

This chapter describes service data, service specifications and servicing procedures which differ from those of the GSF400P ('93-model).

NOTE:

- Any differences between GSF400P ('93-model) and GSF400VV ('97-model) in specifications and service data are clearly indicated with the asterisk marks (*).
- Please refer to the chapters 1 through 10 for details which are not given in this chapter.

CONTENTS

SPECIFICATIONS	11- 1
SERVICE DATA	11- 3
PERIODIC MAINTENANCE SCHEDULE	11- 9
SERVICE INFORMATION	11-10
VC ENGINE (VARIABLE VALVE CONTROL)	11-10
VALVE TRAIN	11-10
ACTUATOR	11-12
DESCRIPTION OF VARIABLE VALVE TIMING/ LIFT OPERATION	11-13
LUBRICATION SYSTEM	11-14
FUEL SYSTEM	11-14
ELECTRICAL	11-15
INSPECTION OF VC MECHANISM OPERATION	11-17
INSPECTION AND ADJUSTMENT OF VALVE CLEARANCE ..	11-18
INSPECTION ON #1 AND #2 CYLINDER INTAKE SIDE	11-20
INSPECTION ON #3 AND #4 CYLINDER INTAKE SIDE	11-26
ENGINE DISASSEMBLY	11-29
CYLINDER HEAD DISASSEMBLY	11-32
CYLINDER HEAD ASSEMBLY	11-34
CAM SPROCKET INSTALLATION	11-36
ENGINE ASSEMBLY	11-37
VALVE TIMING INSPECTION	11-40
LOCATION OF ELECTRICAL PARTS	11-44
OIL CONTROL ACTUATOR SOLENOID INSPECTION	11-44
FAIL SAFE SWITCH INSPECTION	11-45
IGNITOR UNIT INSPECTION	11-45
IGNITOR RELAY INSPECTION	11-46
SPECIAL TOOLS	11-46
VC MECHANISM TROUBLESHOOTING	11-47
WIRING DIAGRAM	11-49
WIRE HARNESS ROUTING	11-50

SPECIFICATIONS

DIMENSIONS AND DRY MASS

Overall length	*2 050 mm (80.7 in)
Overall width	*720 mm (28.3 in)
Overall height	*1 055 mm (41.5 in)
Wheelbase	*1 410 mm (55.5 in)
Ground clearance	*140 mm (5.5 in)
Dry mass	*167 kg (368 lbs)

ENGINE

Type	Four-stroke, water-cooled, DOHC, TSCC
Valve clearance	*IN: 0.10–0.20 mm (0.004–0.008 in) EX: 0.20–0.25 mm (0.008–0.010 in)
Number of cylinders	4
Bore	56.0 mm (2.20 in)
Stroke	40.4 mm (1.59 in)
Piston displacement	398 cm ³ (24.28 cu. in)
Compression ratio	11.8 : 1
Carburetor	*MIKUNI BST32SS, four
Air cleaner	*Non-woven fabric element
Starter system	Electric starter motor
Lubrication system	Wet sump

TRANSMISSION

Clutch	Wet multi-plate type
Transmission	6-speed constant mesh
Gearshift pattern	1-down, 5-up
Primary reduction ratio	1.954 (86/44)
Gear ratios, Low	3.363 (37/11)
2nd	2.307 (30/13)
3rd	1.750 (28/16)
4th	1.437 (23/16)
5th	1.250 (30/24)
Top	1.136 (25/22)
Final reduction ratio	*3.142 (44/14)
Drive chain	DID525V ₉ , 112 links

Asterisk mark (*) indicates the new GSF400VV model specifications.

CHASSIS

Front suspension	Telescopic, coil spring, oil damped
Rear suspension	New link suspension, coil spring, gas/ oil damped, spring pre-load 7-way adjustable
Front suspension stroke	* 130 mm (5.1 in)
Rear wheel travel	* 128 mm (5.0 in)
Caster	* 26° 30'
Trail	* 103 mm (4.1 in)
Steering angle	* 35° (right & left)
Turning radius	* 2.7 m (8.9 ft)
Front brake	Disc brake
Rear brake	Disc brake
Front tire size	* 110/70 R17 54H, tubeless
Rear tire size	* 150/60 R17 66H, tubeless

ELECTRICAL

Ignition type	Electronic Ignition (Fully Transistorized)
Ignition timing	15° B.T.D.C. below 1 500 r/min.
Spark plug	* NGK: CR8E or NIPPONDENSO U24ESR-N
Battery	* 12V 21.6 kC (6 Ah)/10 HR
Generator	Three-phase A.C. Generator
Fuse	* 30/15/15/15/10/10A
Headlight	12V 60/55W
Turn signal light	* 12V 15W
Brake light	* 12V 21W × 2 pcs
Tail/License plate light	12V 5W
Speedometer light	12V 1.7W × 2 pcs
Tachometer light	12V 1.7W × 2 pcs
Neutral indicator light	* 12V 1.7W
High beam indicator light	12V 1.7W
Turn signal indicator light	* 12V 1.7W × 2 pcs
Oil pressure indicator light	* 12V 1.7W
Engine coolant temperature check light	* 12V 1.7W

CAPACITIES

Fuel tank, including reserve	* 15.0 L (4.0/3.3 US/Imp gal)
reserve	* 3.0 L (0.8/0.7 US/Imp gal)
Engine oil, oil change	2 300 ml (2.4/2.0 US/Imp qt)
with filter change	2 800 ml (3.0/2.5 US/Imp qt)
overhaul	3 200 ml (3.4/2.8 US/Imp qt)
Engine coolant (including reserve)	* 2 170 ml (2.3/1.9 US/Imp qt)
Front fork oil (each leg)	* 533 ml (18.0/18.8 US/Imp oz)

These specifications are subject to change without notice.

SERVICE DATA

VALVE + GUIDE

Unit: mm

ITEM		STANDARD		LIMIT
Valve diam.	IN.	22.4		—
	EX.	20.0		—
Valve clearance (when cold)	IN.	*0.10–0.20 Low and High speed cams		—
	EX.	0.20–0.25		—
Valve guide to valve stem clearance	IN.	*0.005–0.045		—
	EX.	*0.015–0.055		—
Valve stem deflection	IN. & EX.	—		0.35
Valve guide I.D.	IN. & EX.	*4.485–4.510		—
Valve stem O.D.	IN.	4.465–4.480		—
	EX.	*4.455–4.470		—
Valve stem runout	IN. & EX.	—		0.05
Valve head thickness	IN. & EX.	—		0.5
Valve stem end length	IN. & EX.	—		2.7
Valve seat width	IN. & EX.	*0.9–1.1		—
Valve head radial runout	IN. & EX.	—		0.03
Valve spring free length	IN.	INNER	—	34.0
		OUTER	—	38.3
	EX.	INNER	—	32.6
		OUTER	—	37.3
Valve spring tension	IN.	INNER	*6.4–7.4 kg at length 30.6 mm	—
		OUTER	*10.8–12.4 kg at length 33.6 mm	—
	EX.	INNER	6.5–7.5 kg at length 28.6 mm	—
		OUTER	8.8–10.2 kg at length 31.6 mm	—

CAMSHAFT + CYLINDER HEAD

Unit: mm

ITEM		STANDARD		LIMIT
Cam height	IN.	*32.66–32.70 (Low speed cam)	*32.3	
		*33.23–33.27 (High speed cam)	*32.9	
	EX.	*32.53–32.57	*32.2	
Camshaft journal oil clearance	IN. & EX.	0.032–0.066	0.150	
Camshaft journal holder I.D.	IN. & EX.	22.012–22.025	—	
Camshaft journal O.D.	IN. & EX.	21.959–21.980	—	
Camshaft runout	IN. & EX.	—	0.10	
Cam chain pin (at arrow "3")	*24th pin			—
Rocker arm I.D.	IN.	*13.000–13.018 (Main arm) *17.000–17.018 (Sub-arm)	—	
	EX.	*13.000–13.018	—	
Rocker arm shaft O.D.	IN. & EX.	*12.973–12.984	—	
Cylinder head distortion	—			0.20

Asterisk mark (*) indicates the new GSF400VV model specifications.

CYLINDER + PISTON + PISTON RING

Unit: mm

ITEM	STANDARD		LIMIT	
Compression pressure	*1 420 kPa (14.2 kg/cm ²)		*990 kPa (9.9 kg/cm ²)	
Compression pressure difference	—		200 kPa (2 kg/cm ²)	
Piston to cylinder clearance	0.050—0.060		0.120	
Cylinder bore	56.000—56.015		56.080	
Piston diam.	55.945—55.960 Measure at 10 mm from the skirt end.		55.880	
Cylinder distortion	—		0.20	
Piston ring free end gap	1st	R	Approx. 5.6	4.5
	2nd	RN	Approx. 5.9	4.7
Piston ring end gap	1st		0.15—0.30	0.5
	2nd		0.30—0.45	0.5
Piston ring to groove clearance	1st		—	0.180
	2nd		—	0.150
Piston ring groove width	1st		0.81—0.83	—
	2nd		0.81—0.83	—
	Oil		1.51—1.53	—
Piston ring thickness	1st		0.77—0.79	—
	2nd		0.77—0.79	—
Piston pin bore	16.002—16.008		16.030	
Piston pin O.D.	15.995—16.000		15.980	

CONROD + CRANKSHAFT

Unit: mm

ITEM	STANDARD		LIMIT
Conrod small end I.D.	16.010—16.018		16.040
Conrod big end side clearance	0.10—0.20		0.30
Conrod big end width	16.95—17.00		—
Crank pin width	17.10—17.15		—
Conrod big end oil clearance	0.024—0.048		0.080
Crank pin O.D.	29.976—30.000		—
Crankshaft journal oil clearance	0.012—0.036		0.080
Crankshaft journal O.D.	31.976—32.000		—
Crankshaft thrust bearing thickness	Left side	2.350—2.500	—
	Right side	2.425—2.450	—
Crankshaft thrust clearance	0.045—0.100		—
Crankshaft runout	—		0.05

OIL PUMP

ITEM	STANDARD	LIMIT
Oil pump reduction ratio	*1.931 (77/44 x 32/29)	—
Oil pressure (at 60°C, 140°F)	Above 250 kPa (2.5 kg/cm ²) Below 600 kPa (6.0 kg/cm ²) at 3 000 r/min.	—

SERVICE DATA

CLUTCH

Unit: mm

ITEM	STANDARD	LIMIT
Clutch lever play	10–15	—
Clutch release screw	¼–½ turn back	—
Drive plate thickness	2.90–3.10	2.60
Drive plate claw width	11.8–12.0	11.0
Driven plate distortion	—	0.10
Clutch spring free length	—	31.0

THERMOSTAT + RADIATOR + FAN

ITEM	STANDARD	LIMIT	
Thermostat valve opening temperature	74.5–78.5°C (166.1–173.3°F)	—	
Thermostat valve lift	Over 7 mm at 90°C (194°F)	—	
Radiator cap valve opening pressure	110 kPa (1.1 kg/cm ²)	—	
Cooling fan thermo-switch operating temperature	ON	Approx. 95°C (203°F)	—
	OFF	Approx. 88°C (190.4°F)	—
Water thermo-switch operating temperature	ON	Approx. 117°C (243°F)	—
	OFF	Approx. 110°C (230°F)	—

TRANSMISSION + DRIVE CHAIN

Unit: mm Except ratio

ITEM	STANDARD	LIMIT	
Primary reduction ratio	1.954 (86/44)	—	
Final reduction ratio	*3.142 (44/14)	—	
Gear ratios	Low	3.363 (37/11)	—
	2nd	2.307 (30/13)	—
	3rd	1.750 (28/16)	—
	4th	1.437 (23/16)	—
	5th	1.250 (30/24)	—
	Top	1.136 (25/22)	—
Shift fork to groove clearance	No.1, No.2 & No.3 0.10–0.30	0.50	
Shift fork groove width	No.1, No.2 & No.3 5.5–5.6	—	
Shift fork thickness	No.1, No.2 & No.3 5.3–5.4	—	
Countershaft length (Low to 2nd)	113.1–113.2	—	
Drive chain	Type	D.I.D.: DID525V ₉	—
	Links	*112	—
	20-pitch length	—	319.4
Drive chain slack	25–35	—	
Gearshift lever height	*50	—	

CARBURETOR

ITEM		SPECIFICATION
		E-30
Carburetor type		MIKUNI BST32SS
Bore size		32 mm
I.D. No		*33DE
Idle r/min.		*1 300 ± 100 r/min.
Float height		14.6 ± 1.0 mm
Main jet	(M.J.)	*# 90
Jet needle	(J.N.)	*5DF17-3rd
Needle jet	(N.J.)	*O-1
Throttle valve	(Th.V.)	*# 95
Pilot jet	(P.J.)	*# 30
Pilot screw	(P.S.)	*PRE-SET (1¼ turns back)
Throttle cable play		0.5–1.0 mm (0.02–0.04 in)

ELECTRICAL

Unit: mm

ITEM		SPECIFICATION	NOTE
Ignition timing		15° B.T.D.C. at 1 500 r/min.	
Firing order		1-2-4-3	
Spark plug	Type	ND: U24ESR-N N.G.K.: CR8E	
	Gap	0.7–0.8	
Spark performance		Over 8 at 1 atm.	
Signal coil resistance		80–120 Ω	Tester range: x 10 Ω
Ignition coil resistance	Primary	⊕ tap–⊖ tap 2.5–3.8 Ω	Tester range: x 1 Ω
	Secondary	Plug cap–Plug cap 30–50 kΩ	Tester range: x 1 kΩ
Actuator solenoid resistance		*14.2–15.2	Tester range: x 1 Ω
Generator no-load voltage		More than 70 V (AC) at 5 000 r/min.	When cold
Regulated voltage		13.5–15.5 V at 5 000 r/min.	
Starter relay resistance		3–5 Ω	
Battery	Type designation	*YTX7A-BS	
	Capacity	*12V 21.6 kC (6 Ah)/10 HR	
	Standard electrolyte S.G.	1.32 at 20°C (68°F)	
Fuse size	Headlight	HI/LO	*15/15 A
	Signal		*15 A
	Ignition		10 A
	Tail		*10 A
	Main		*30 A

WATTAGE

Unit:W

ITEM		SPECIFICATION
Headlight	HI	60
	LO	55
Brake light		*21 x 2pcs
Turn signal light		*15
Tachometer light		1.7 x 2pcs
Speedometer light		1.7 x 2pcs
Water temp. check light		*1.7
Turn signal indicator light		*1.7 x 2pcs
High beam indicator light		1.7
Neutral indicator light		*1.7
Oil pressure indicator light		*1.7
Tail/License light		5

BRAKE + WHEEL

Unit: mm

ITEM	STANDARD		LIMIT
Rear brake pedal height	*50		—
Brake disc thickness	Front	4.5 ± 0.2	4.0
	Rear	*5.0 ± 0.2	*4.5
Brake disc runout	—		0.30
Master cylinder bore	Front	*15.870—15.913	—
	Rear	12.700—12.743	—
Master cylinder piston diam.	Front	*15.827—15.854	—
	Rear	12.657—12.684	—
Brake caliper cylinder bore	Front	*30.230—30.306	—
		33.960—34.036	—
Brake caliper piston diam.	Front	*30.150—30.200	—
		33.884—33.934	—
Wheel rim runout	Axial	—	2.0
	Radial	—	2.0
Wheel axle runout	Front	—	0.25
	Rear	—	0.25
Tire size	Front	*110/70R-17 54H	—
	Rear	*150/60R-17 66H	—
Tire tread depth	Front	—	1.6
	Rear	—	2.0

SUSPENSION

Unit: mm

ITEM	STANDARD	LIMIT	NOTE
Front fork stroke	*130	—	
Front fork spring free length	—	*286	
Front fork oil level	*110	—	
Rear shock absorber spring adjuster	4/7	—	
Rear wheel travel	*128	—	
Swingarm pivot shaft runout	—	0.3	

TIRE PRESSURE

COLD INFLATION TIRE PRESSURE	SOLO RIDING			DUAL RIDING		
	kPa	kg/cm ²	psi	kPa	kg/cm ²	psi
FRONT	200	2.00	29	200	2.00	29
REAR	225	2.25	33	250	2.50	36

FUEL + OIL + COOLANT

ITEM	SPECIFICATION	NOTE
Fuel type	Gasoline used should be graded 85-95 octane or higher. An unleaded gasoline is recommended.	
Fuel tank including reserve	*15.0 L (4.0/3.3 US/Imp gal)	
reserve	*3.0 L (0.8/0.7 US/Imp gal)	
Engine oil type	SAE 10W/40, API SF or SG	
Engine oil capacity	Change 2 300 ml (2.4/2.0 US/Imp qt)	
	Filter change 2 800 ml (3.0/2.5 US/Imp qt)	
	Overhaul 3 200 ml (3.4/2.8 US/Imp qt)	
Front fork oil type	Fork oil # 10	
Front fork oil capacity (each leg)	*533 ml	
Brake fluid type	DOT4	
Coolant type	Use an anti-freeze/coolant compatible with aluminum radiator, mixed with distilled water only, at the ratio of 50:50.	
Coolant including reserve	*2 170 ml	

PERIODIC MAINTENANCE SCHEDULE

Interval; This interval should be judged by odometer reading or months, whichever comes first.

Item	Interval	km	1 000	6 000	12 000	18 000	24 000
		miles	600	4 000	7 500	11 000	15 000
		months	1	6	12	18	24
Air cleaner elements			-	I	I	R	I
Exhaust pipe bolts and muffler bolts			T	-	T	-	T
Valve clearance			-	-	I	-	I
Spark plugs			-	I	R	I	R
Fuel hose			-	I	I	I	I
			Replace every 4 years.				
Engine oil			R	R	R	R	R
Engine oil filter			R	-	-	R	-
Engine idle speed			I	I	I	I	I
Throttle cable play			I	I	I	I	I
Carburetor synchronization			-	-	I	-	I
Clutch			-	I	I	I	I
Drive chain			I	I	I	I	I
			Clean and lubricate every 1 000 km (600 miles).				
Radiator hose			-	I	I	I	I
			Replace every 4 years.				
Engine coolant			Replace every 2 years.				
Brakes			I	I	I	I	I
Brake hose			-	I	I	I	I
			Replace every 4 years.				
Brake fluid			-	I	I	I	I
			Replace every 2 years.				
Tires			-	I	I	I	I
Steering			I	-	I	-	I
Front forks			-	-	I	-	I
Rear suspension			-	-	I	-	I
Chassis bolts and nuts			T	T	T	T	T

Note: I=Inspection and adjust, clean, replace or lubricate as necessary;

R=Replace; T=Tighten

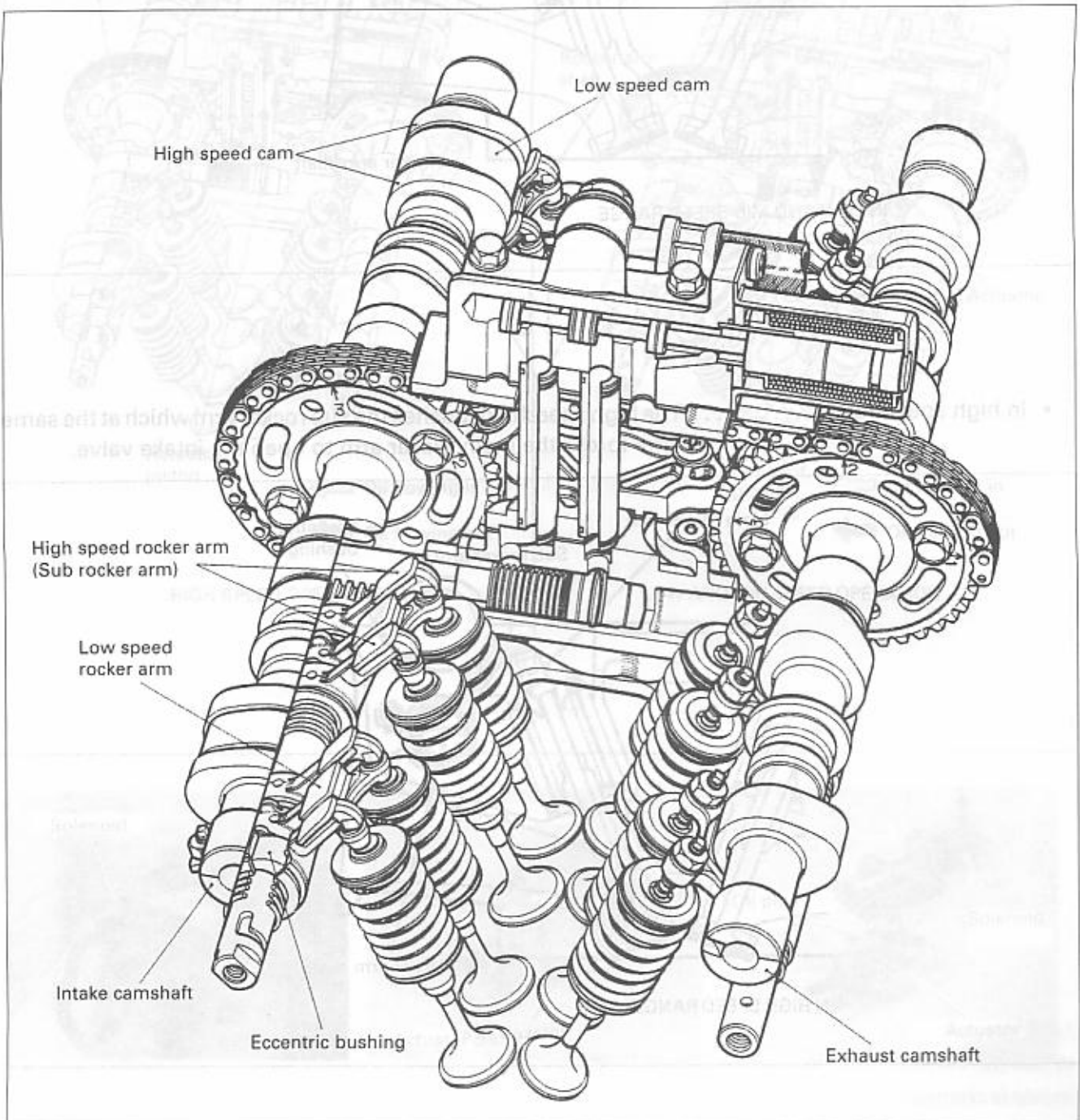
SERVICE INFORMATION

VC ENGINE (VARIABLE VALVE CONTROL)

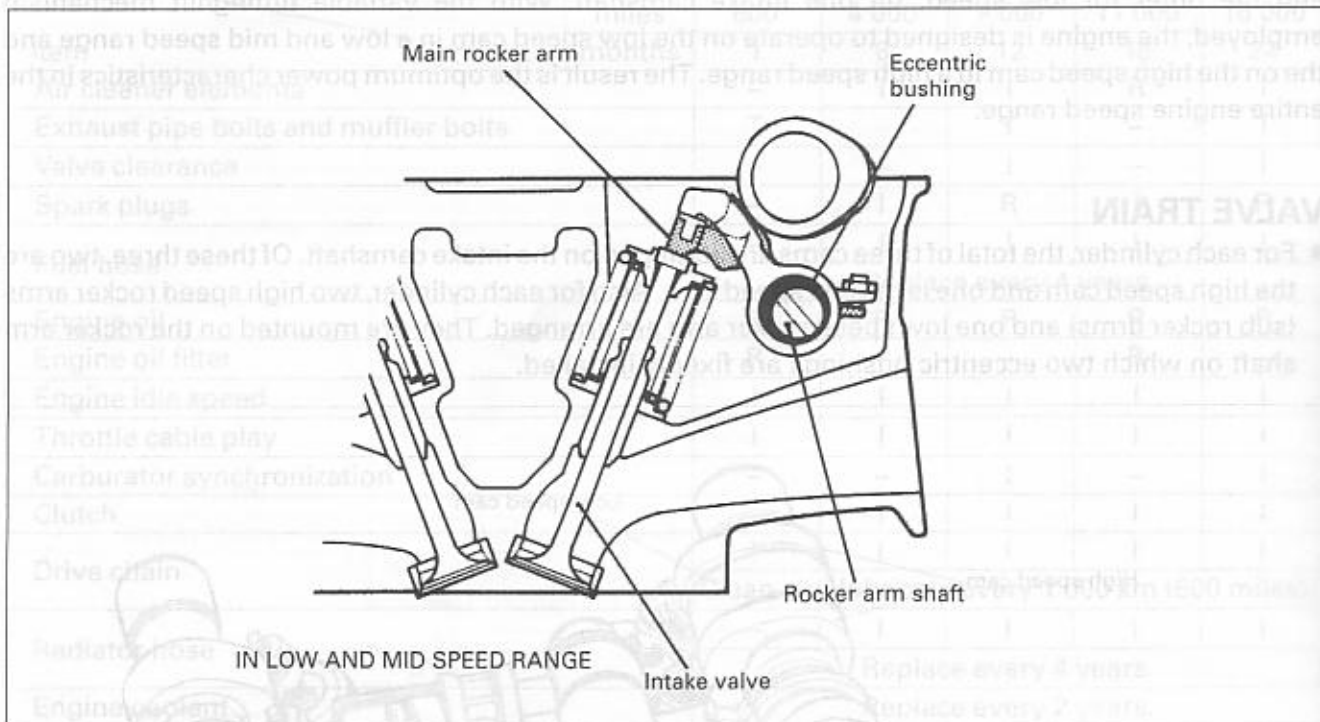
The model GSF400VV is mounted with VC engine which uses two types of cam lobe, one for high speed and the other for low speed, on one intake camshaft. With the variable timing/lift mechanism employed, the engine is designed to operate on the low speed cam in a low and mid speed range and the on the high speed cam in a high speed range. The result is the optimum power characteristics in the entire engine speed range.

VALVE TRAIN

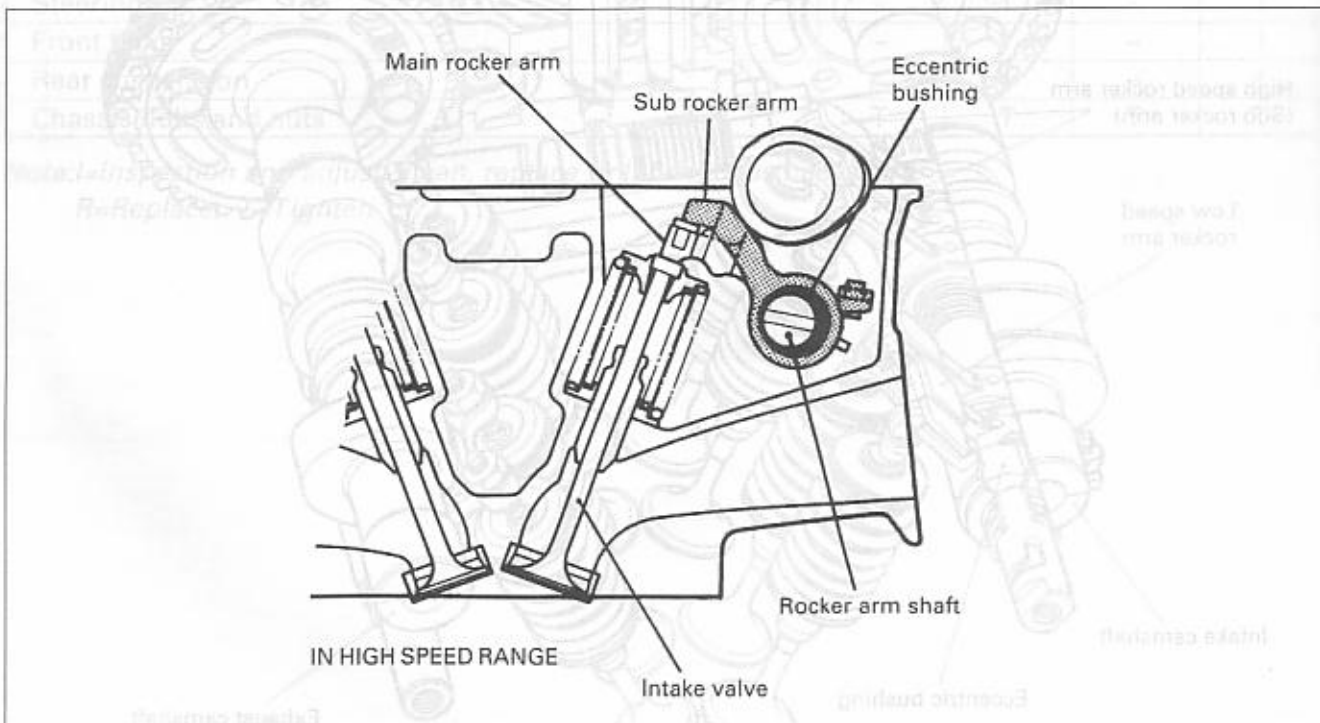
- For each cylinder, the total of three cams are equipped on the intake camshaft. Of these three, two are the high speed cam and one is the low speed cam. Also for each cylinder, two high speed rocker arms (sub rocker arms) and one low speed rocker arm are arranged. They are mounted on the rocker arm shaft on which two eccentric bushings are fixedly installed.



- Changing of valve timing/lift is made when the sub rocker arm position relative to the camshaft is changed with the eccentric bushings turned together with the rocker arm shaft.
 - In low and mid speed range . . . The low speed cam pushes the main rocker arm to open the intake valve.

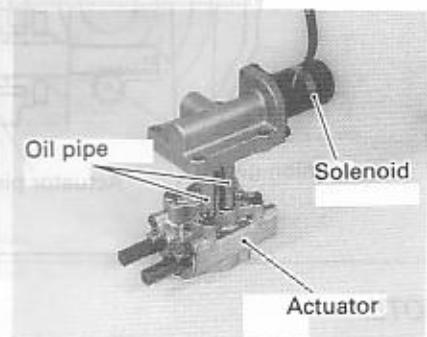
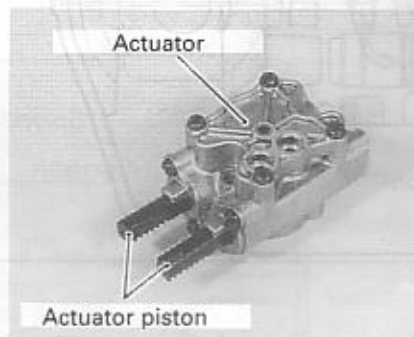
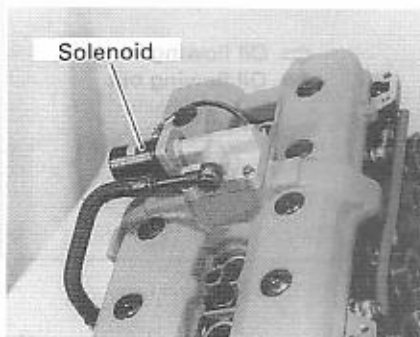
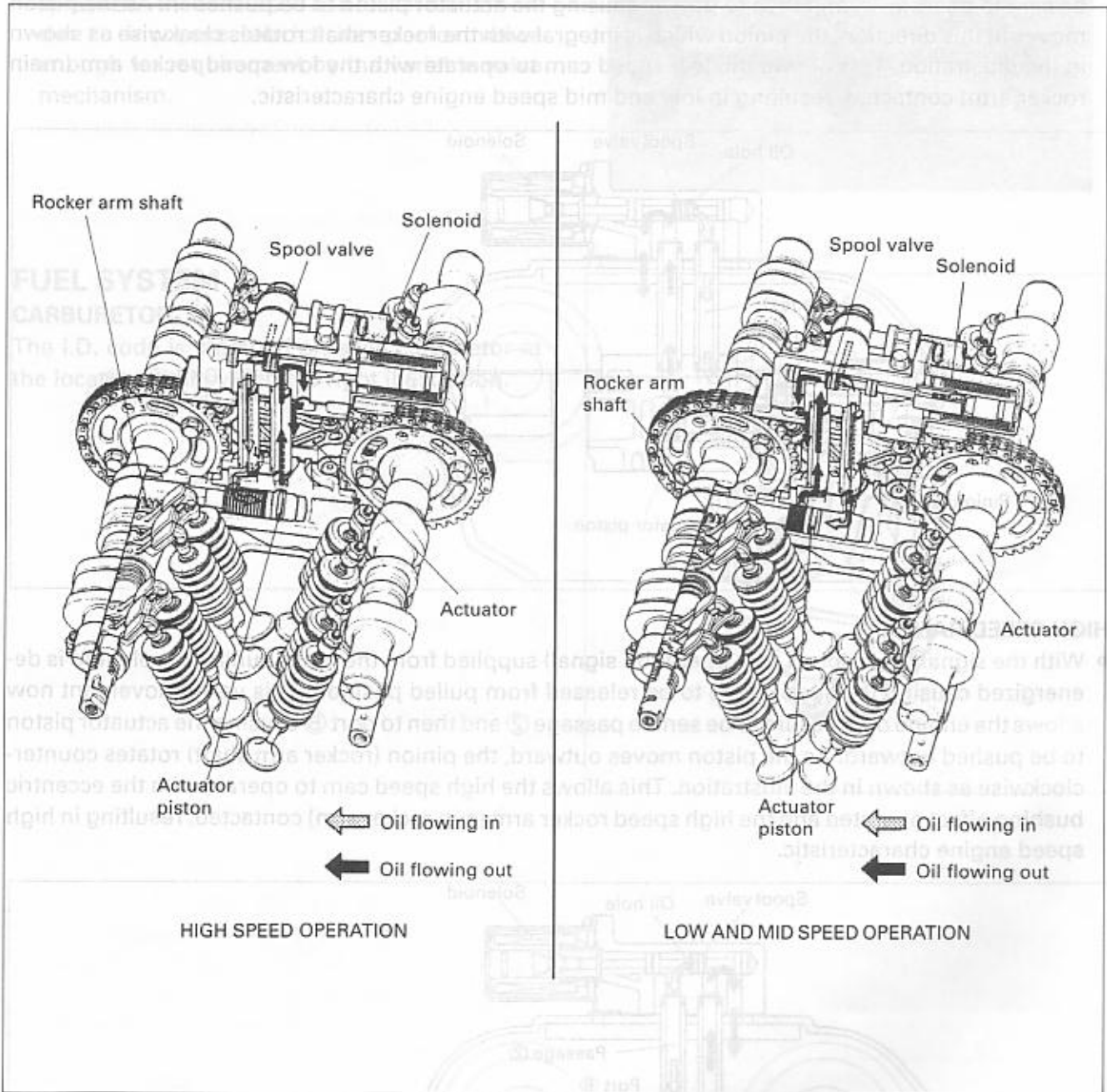


- In high speed range The high speed cam pushes the sub rocker arm which at the same time forces the main rocker arm to open the intake valve.



ACTUATOR

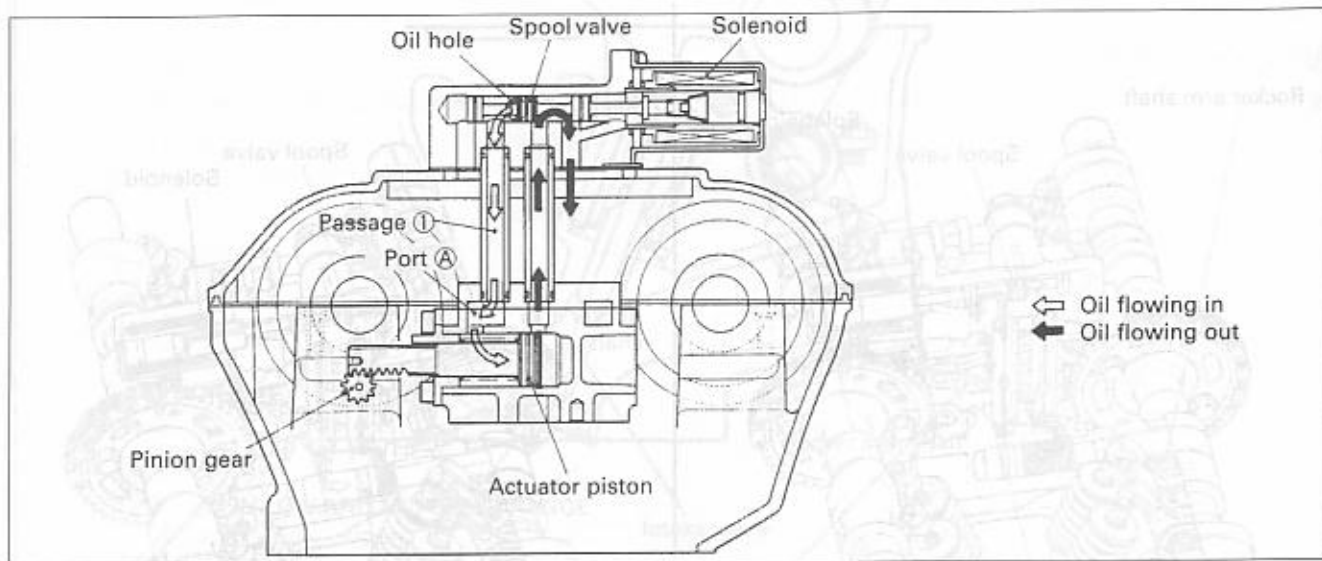
- The rocker arm shaft is driven by the actuator piston through the rack-and-pinion mechanism.
- The actuator piston operates on the engine oil pressure supplied through the spool valve. This valve moves together with the solenoid which is controlled by the signal sent from the ignitor unit.



DESCRIPTION OF VARIABLE VALVE TIMING/LIFT OPERATION

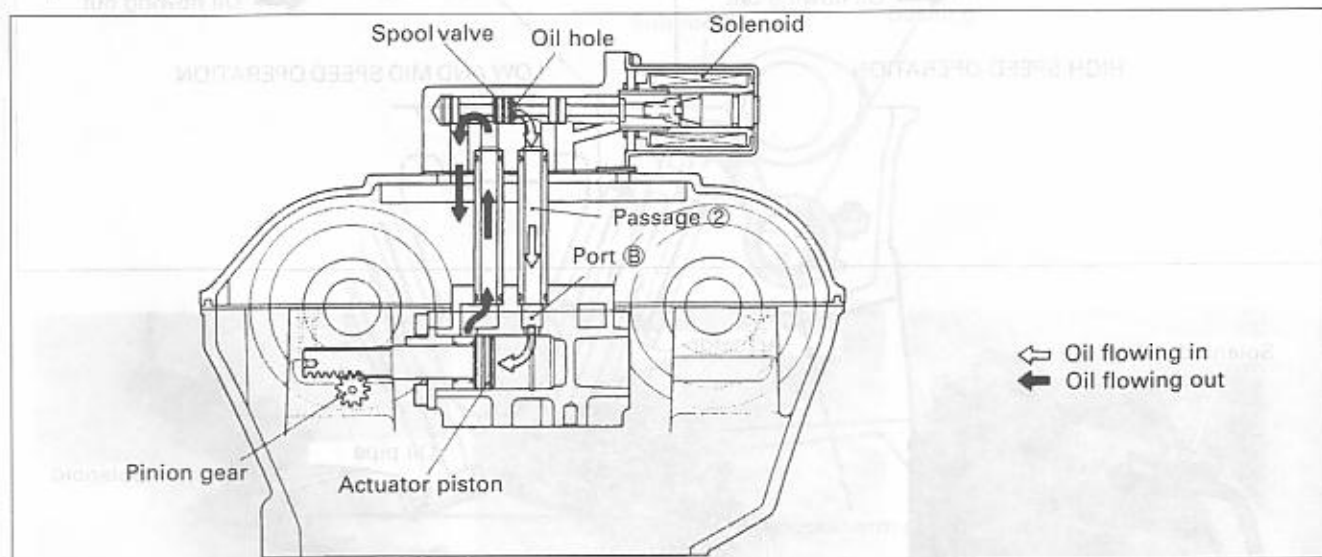
LOW AND MID SPEED RANGE

- With the signal (low speed cam operation signal) supplied from the ignitor unit, the solenoid is energized causing the spool valve to be pulled in. This valve movement allows the engine oil pressure to be sent to passage ① and then to port (A) causing the actuator piston to be pushed in. As the piston moves in this direction, the pinion which is integral with the rocker shaft rotates clockwise as shown in the illustration. This allows the low speed cam to operate with the low speed rocker arm (main rocker arm) contacted, resulting in low and mid speed engine characteristic.



HIGH SPEED RANGE

- With the signal (high speed cam operation signal) supplied from the ignitor unit, the solenoid is de-energized causing the spool valve to be released from pulled position. This valve movement now allows the engine oil pressure to be sent to passage ② and then to port (B) causing the actuator piston to be pushed outward. As the piston moves outward, the pinion (rocker arm shaft) rotates counter-clockwise as shown in the illustration. This allows the high speed cam to operate with the eccentric bushing effect operated and the high speed rocker arm (sub rocker arm) contacted, resulting in high speed engine characteristic.



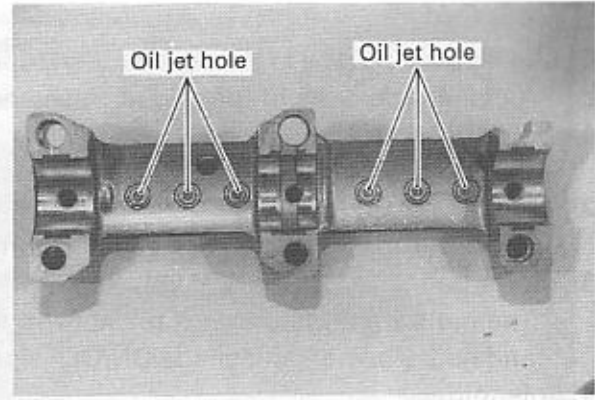
NOTE:

When the valve timing/lift control comes in operation, a switching sound is heard and at this time, the mode is changed, from low/mid speed to high speed mode or from high speed to low/mid speed mode.

LUBRICATION SYSTEM

CAMSHAFT HOLDER (OIL SHOWER TYPE)

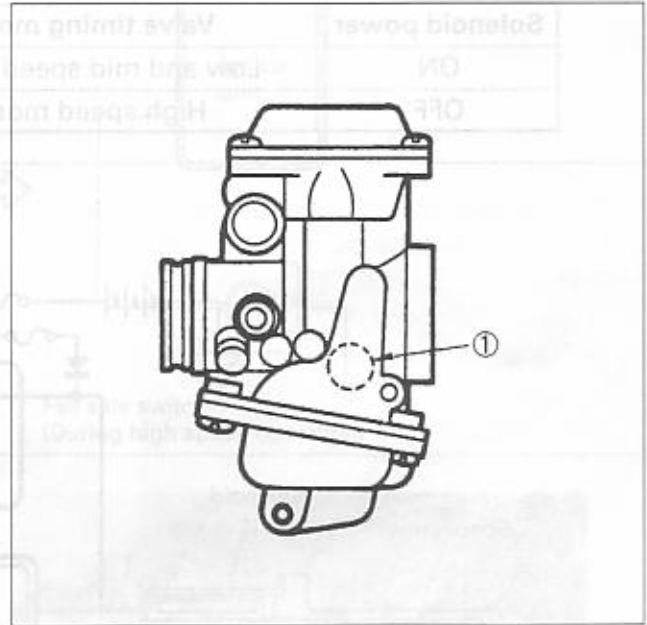
- Along the center line of the camshaft holder, oil jet holes are provided, from which engine oil is sprayed to the cam lobes and rocker arms in order to increase lubrication performance enough for requirement by the variable valve mechanism.



FUEL SYSTEM

CARBURETOR

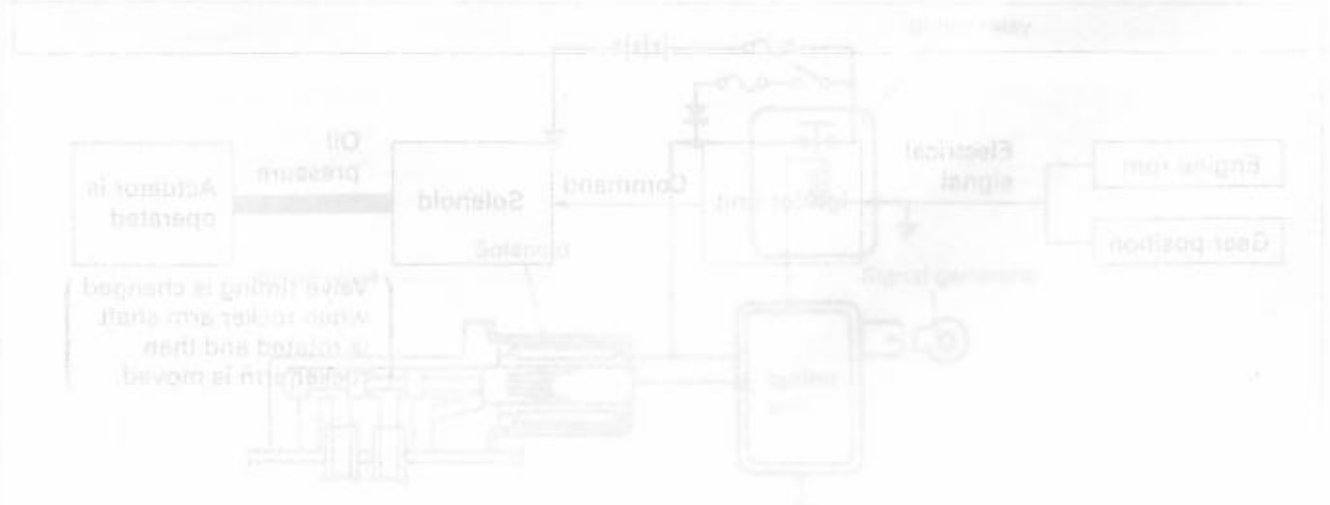
The I.D. code is stamped on each carburetor at the location ① shown in the right illustration.



IGNITOR RELAY

- The ignitor relay remains on without power or to the solenoid from the battery for 1-3 seconds even after the engine has started. This is to ensure the relay energizing power is supplied to the ignitor.

During this 5-8 second period, the solenoid valve is held in the low and speed position. When the power is cut off, the solenoid valve returns to the high speed position by the spring force inside the solenoid and comes back to the high speed position.



ELECTRICAL

- Changing between the high speed and low speed cam in the variable valve timing/lift mechanism is controlled on the basis of the engine speed and gear position conditions.

1) Signal generator

- The signal generator produces the engine rpm signal.

2) Gear position switch

- The gear position switch detects the current gear position.

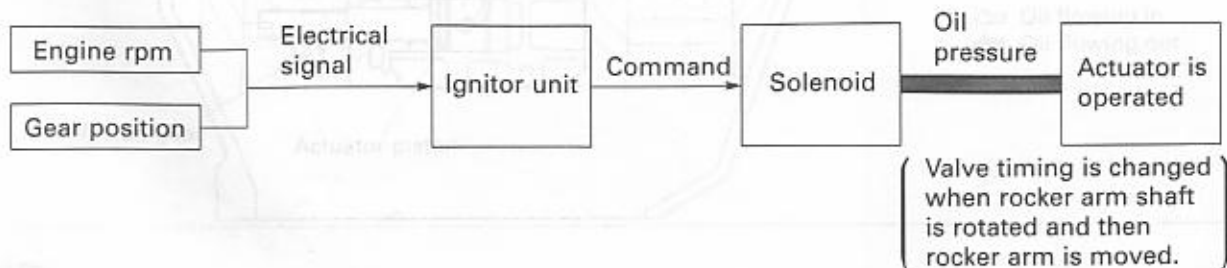
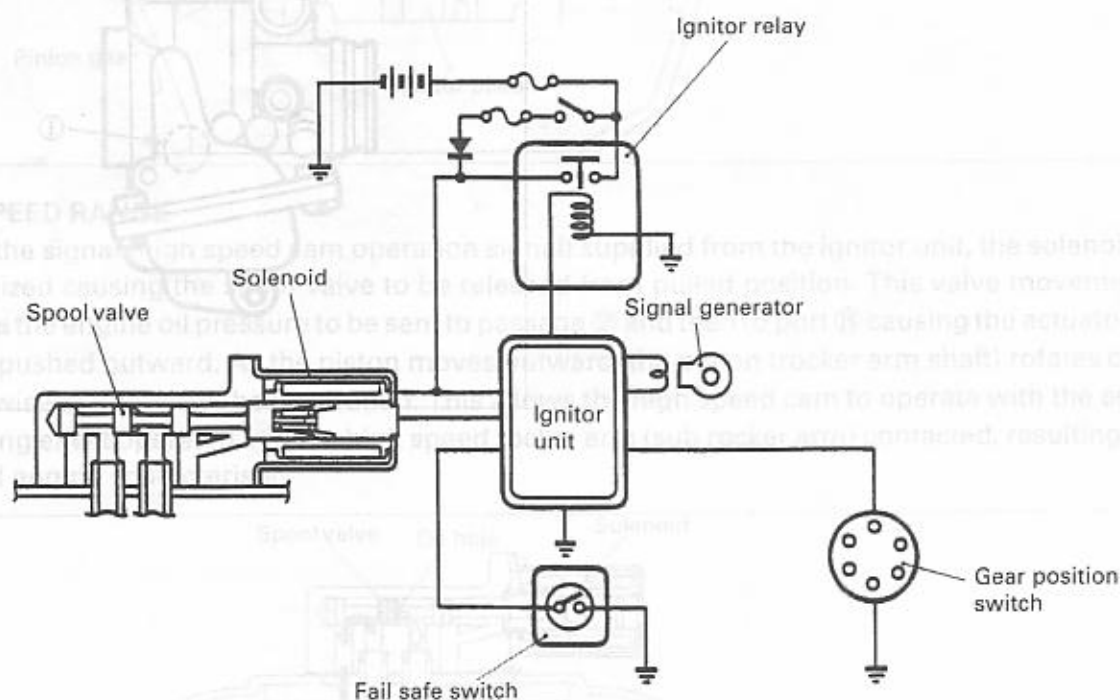
3) Ignitor unit

- The ignitor unit determines the appropriate timing for the system on the basis of engine rpm and gear position and sends ON/OFF signal to the solenoid.

4) Solenoid

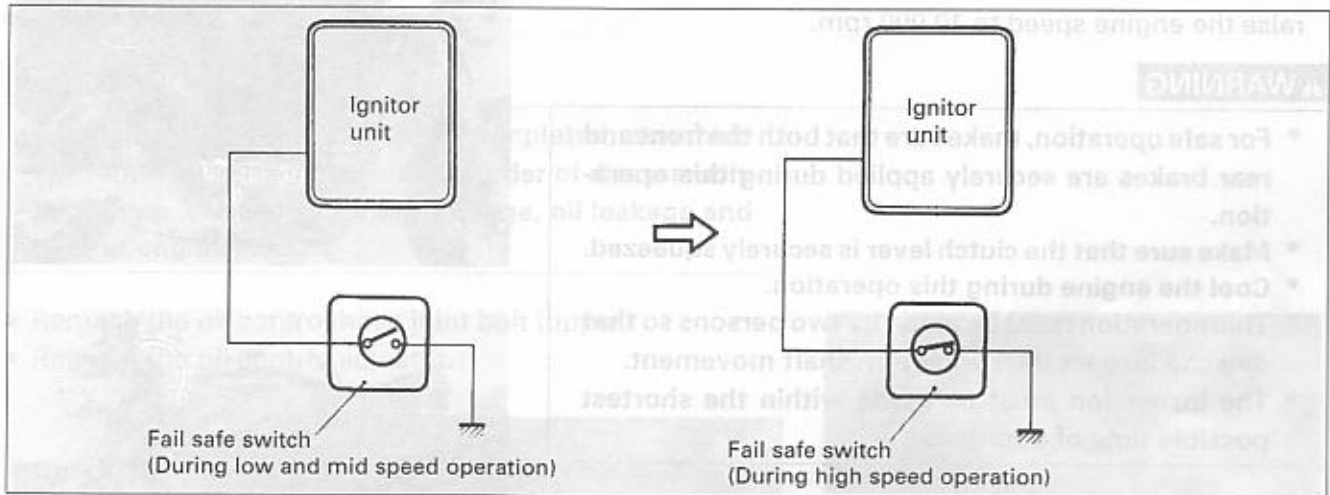
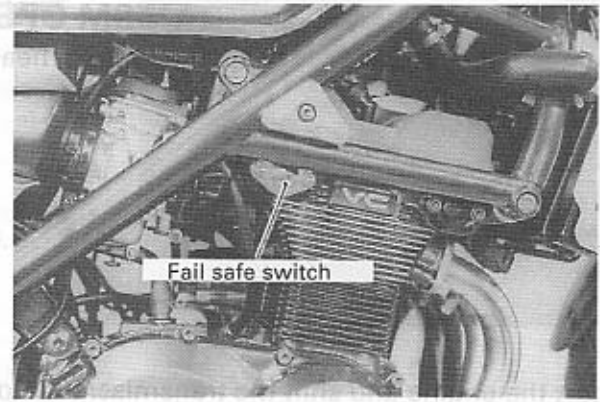
- Based on the signal supplied from the ignitor, the solenoid operates the spool valve and changes the oil pressure circuit for the actuator assembly.

Solenoid power	Valve timing mode
ON	Low and mid speed mode
OFF	High speed mode



FAIL SAFE SWITCH

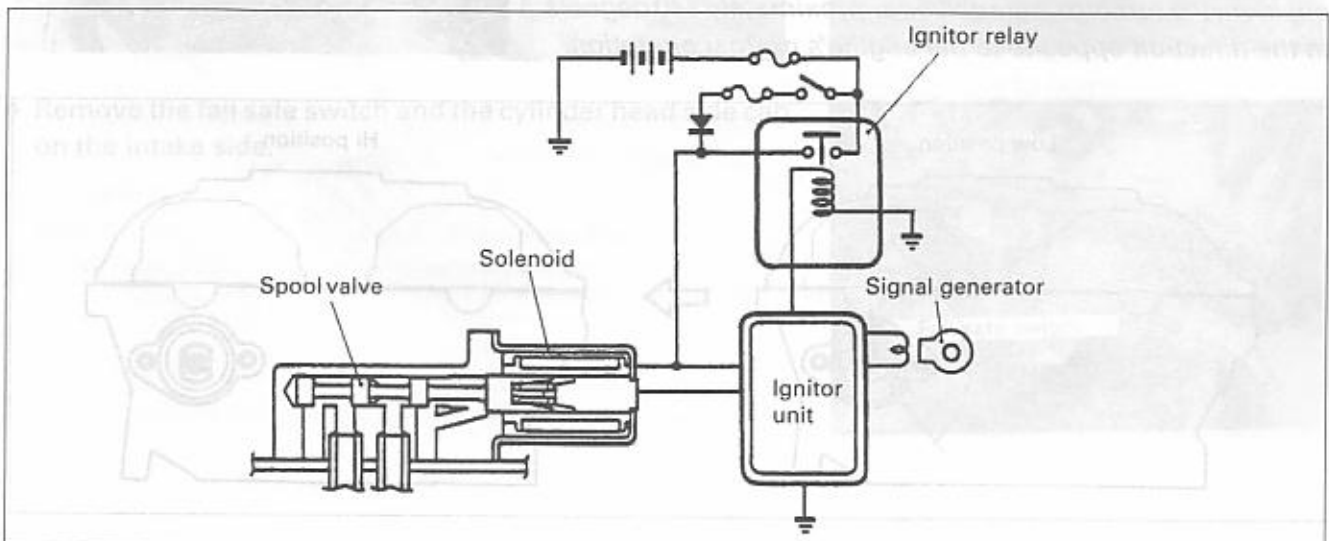
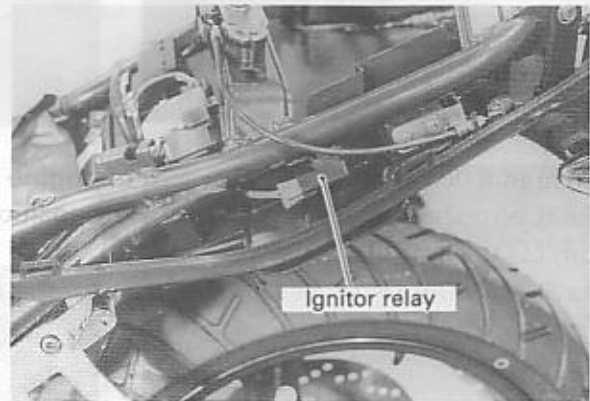
- The fail safe switch is installed on the side of intake rocker arm shaft. This switch detects the condition that the rocker arm shaft has turned to the high speed position.



IGNITOR RELAY

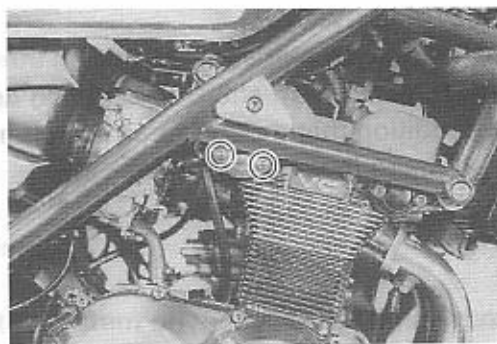
- The ignitor relay remains on and sending power to the solenoid from the battery for 3–8 seconds even after the engine has stalled with the relay energizing power supplied from the ignitor.

During this 5–8 seconds period, the spool valve is held in the low and mid speed position. When the power is interrupted after the 5–8 seconds period, the spool valve returns by the spring force inside the solenoid and comes back to the high speed position.



INSPECTION OF VC MECHANISM OPERATION

- Remove the fail safe switch and the cylinder head side cap.



- Start the engine and shift the transmission into low gear.
- With the clutch lever squeezed, turn the throttle grip to raise the engine speed to 10 000 rpm.

⚠ WARNING

- * For safe operation, make sure that both the front and rear brakes are securely applied during this operation.
- * Make sure that the clutch lever is securely squeezed.
- * Cool the engine during this operation.
- * This operation must be made by two persons so that one can inspect the rocker arm shaft movement.
- * The inspection must be made within the shortest possible time of duration.

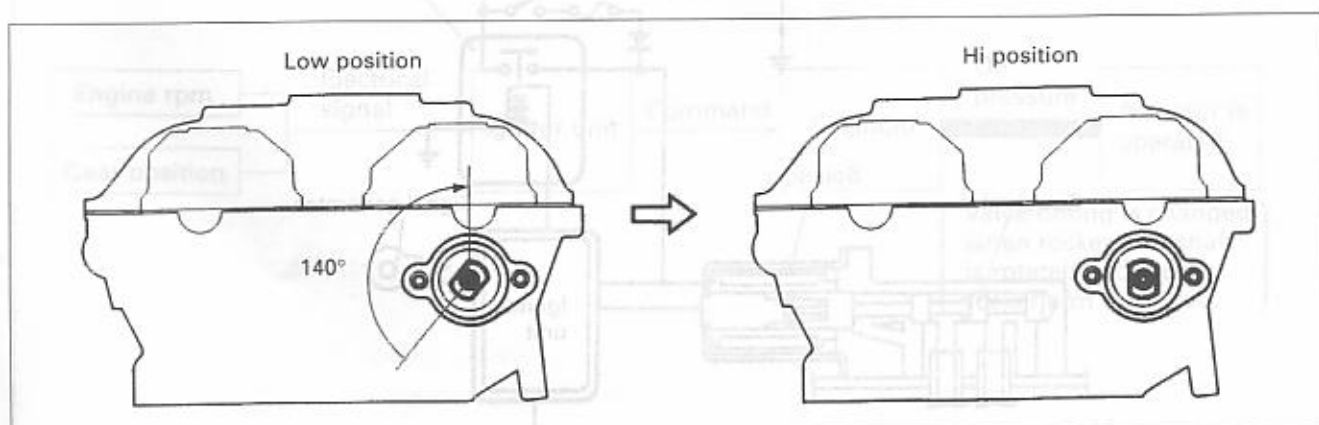


- Between 8 000 rpm and 10 000 rpm of engine speed, the rocker arm shaft starts to turn and their position changes from LO to HI position.
- Check both the two rocker arm shafts on the intake side turn.



NOTE:

When the rocker arm shaft moves from the low to high speed position, the turning angle will be approximately 140 degrees in the direction opposite to the engine's normal operation.



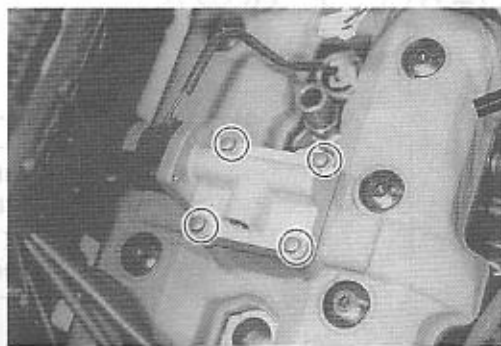
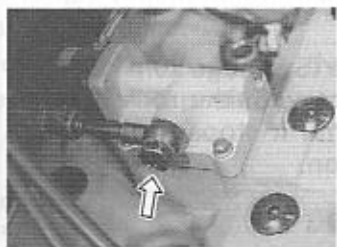
INSPECTION AND ADJUSTMENT OF VALVE CLEARANCE

- Remove the seat.
- Remove the fuel tank.
- Drain coolant from the cooling system.
- Remove the water hose.
- Remove the thermostat inlet connector bracket ①.
- Remove the radiator inlet hose.
- Loosen the radiator mounting bolt.
- Disconnect the spark plug caps.
- Remove the ignition coil.
- Disconnect the throttle cable at the handlebars.
- Disconnect the starter cable.

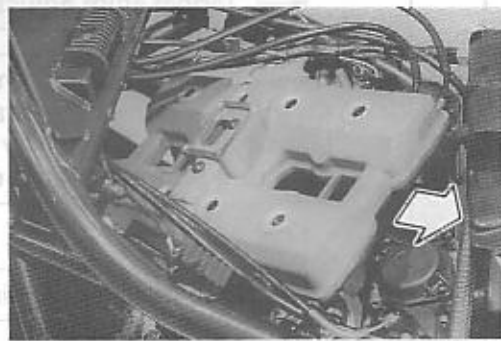
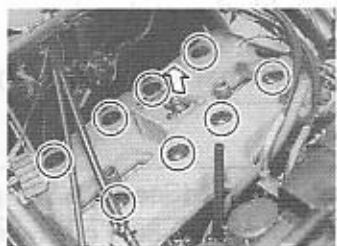
⚠ CAUTION

After the adjustment has been completed, assemble the removed parts in the reverse order of disassembly procedure. Check for coolant leakage, oil leakage and ease of engine starting.

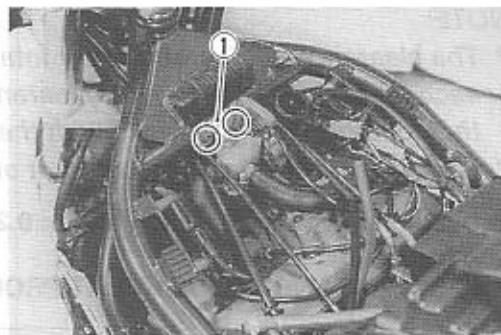
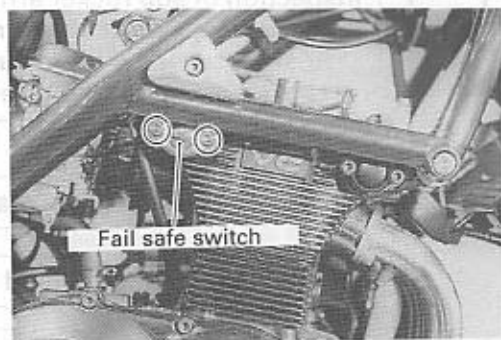
- Remove the oil control hose joint bolt (upper).
- Remove the oil control actuator.



- Pull free the VC oil line pipe.
- Remove the cylinder head cover.



- Remove the fail safe switch and the cylinder head side cap on the intake side.

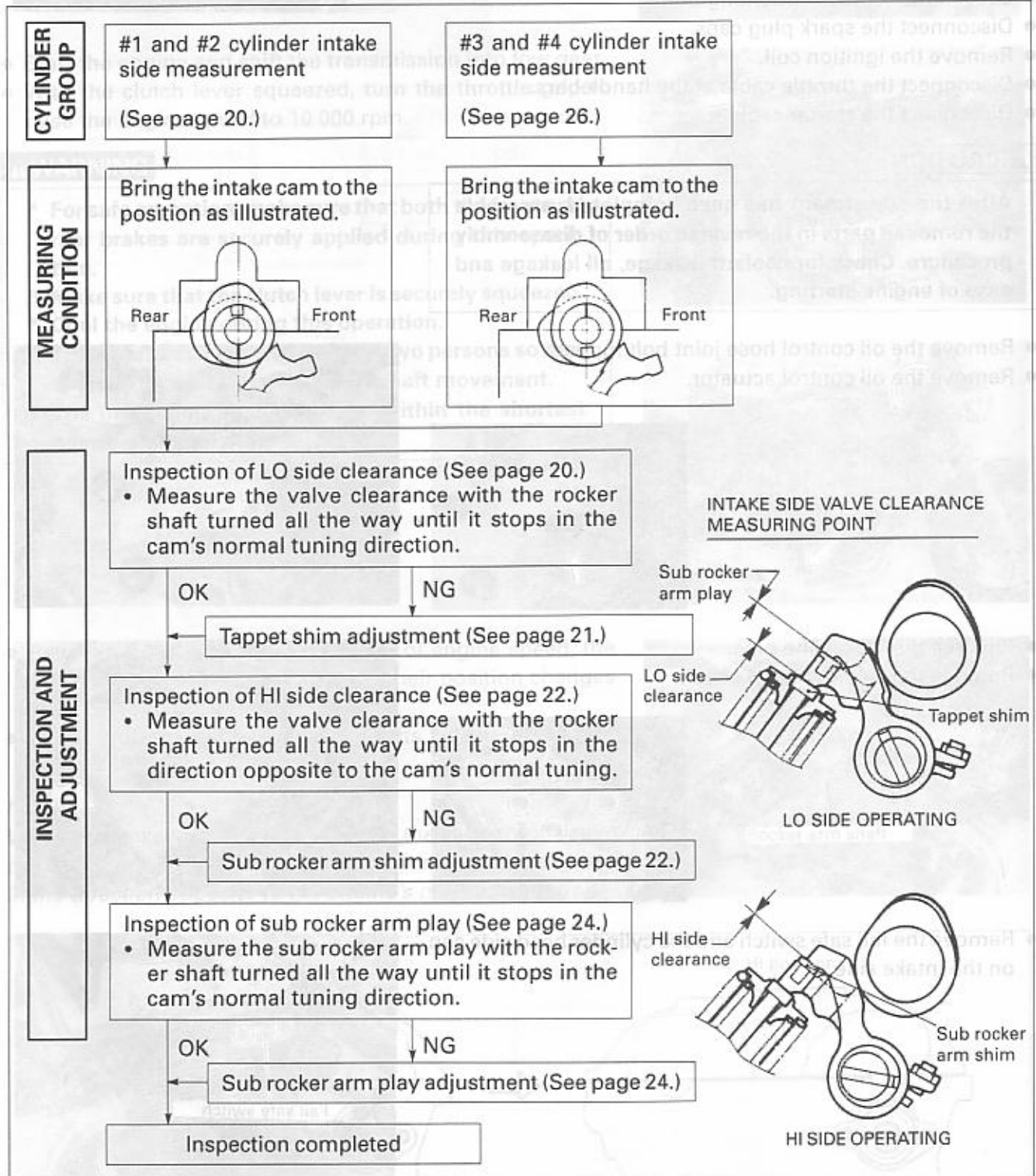


NOTE:

- * The clearance measurement for intake side must be performed for 24 places in total, eight places each for LO and HI side valve clearances and another eight places for sub rocker arm play. Perform the operation in accordance with the following "INSPECTION AND ADJUSTMENT PROCEDURE."
- * For the inspection and adjustment of exhaust valve clearance, refer to GSF400 Service Manual.

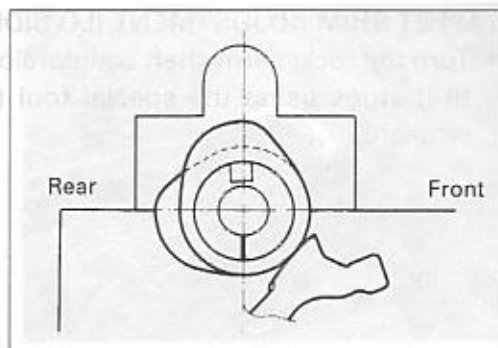
Exhaust side valve clearance (cold): 0.20–0.25 mm

INSPECTION AND ADJUSTMENT PROCEDURE



INSPECTION ON #1 AND #2 CYLINDER INTAKE SIDE

- Bring the line on the intake camshaft right side end face to the position as illustrated.



- Attach the special tool (Rocker shaft turning wrench) to the rocker arm shaft being measured.

TOOL 09917-13231: Rocker shaft turning wrench

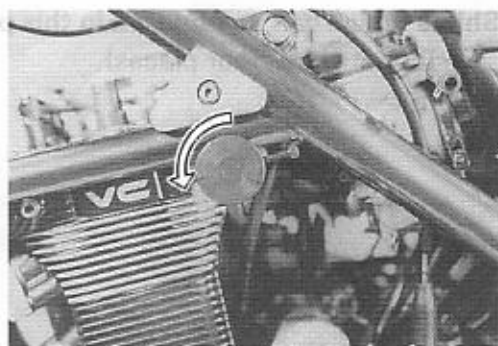
NOTE:

In LO position, set the special tool so that its handle points rearward.



LO SIDE VALVE CLEARANCE INSPECTION

- With the rocker arm shaft turned counterclockwise using the special tool (Rocker shaft turning wrench) all the way until it stops, check for the LO side clearance.
- During inspection, hold the special tool handle so that the rocker arm shaft may not move from the LO position.



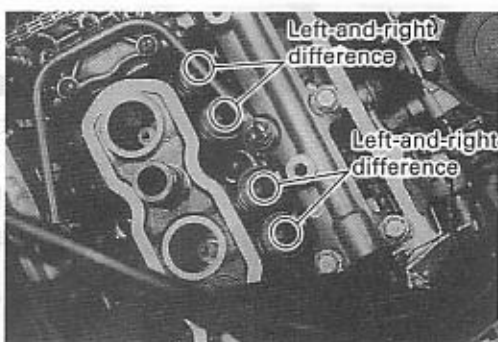
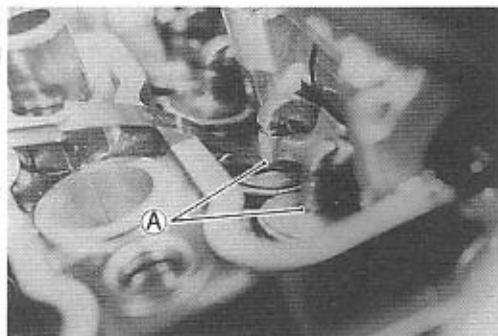
Measuring point: Insert the thickness gauge into the clearance **A** between the valve and main rocker arm.

LO side valve clearance (cold)

Inlet side: 0.10–0.20mm (0.004–0.008 in)

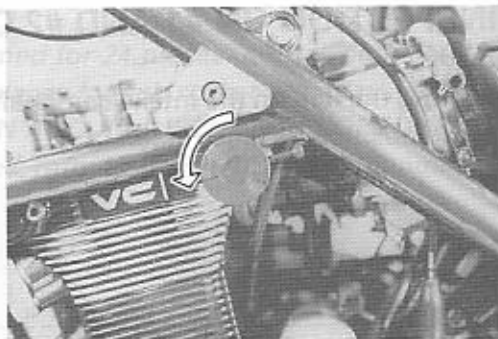
CAUTION

- * For one cylinder, left-and-right difference of the LO side valve clearance must be within 0.05 mm (0.002 in).
- * When the LO side valve clearance is found to be within the specification, check the HI side valve clearance. (See page 22.)
- * If the measurement is out of the specification, perform the tappet shim adjustment. (See page 21.)

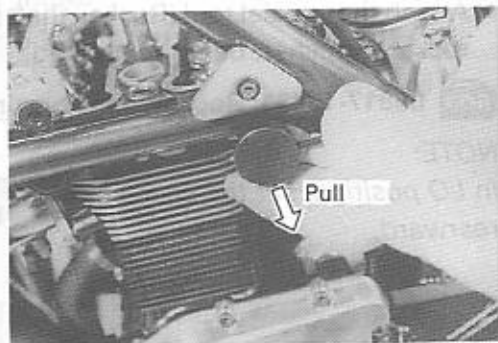


TAPPET SHIM ADJUSTMENT (LO SIDE)

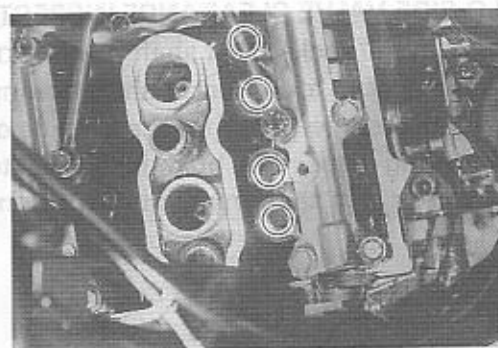
- Turn the rocker arm shaft counterclockwise all the way until it stops using the special tool (Rocker shaft turning wrench).



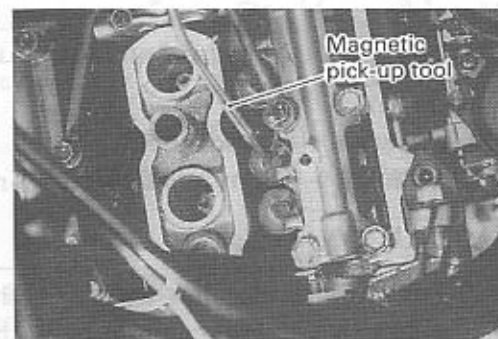
- In this condition, pull the special tool (Rocker shaft turning wrench) axially and the rocker arms for two cylinders will side together with the rocker arm shaft so that the shims can be replaced.

**Shims which can be replaced in this procedure:**

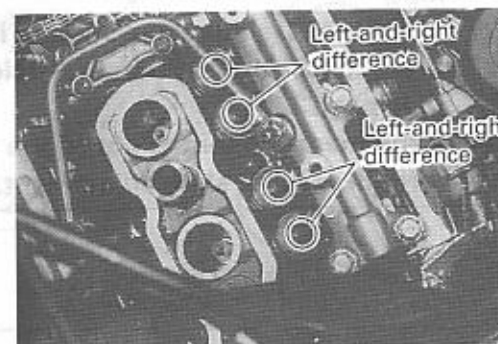
- Tappet shim (four places)



- Using a magnetic pick-up tool, pull out the shim.
- Replace the shim referring to the tappet shim selection table. (See pages 27 and 28.)

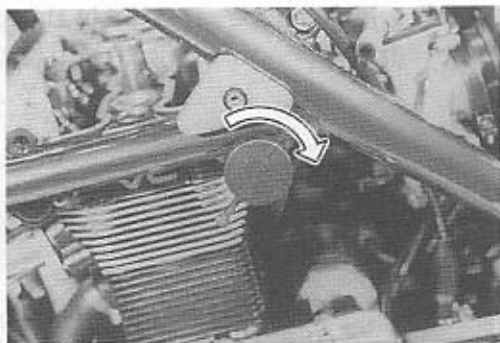
**CAUTION**

- * For one cylinder, left-and-right difference of the LO side valve clearance must be within 0.05 mm (0.002 in).
- * When the LO side tappet shim has been replaced, make sure to check the HI side valve clearance. (See page 22.)

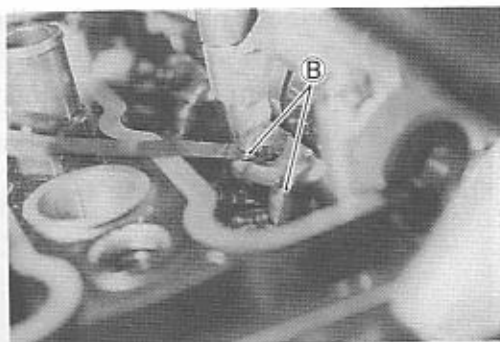


HI SIDE VALVE CLEARANCE INSPECTION

- With the rocker arm shaft turned clockwise using the special tool (Rocker shaft turning wrench) all the way until it stops, check for the HI side valve clearance.
- During inspection, hold the special tool handle so that the rocker arm shaft may not move from the HI position.



Measuring point: Insert the thickness gauge into the clearance ⑥ between the valve and main rocker arm.



HI side valve clearance (cold)

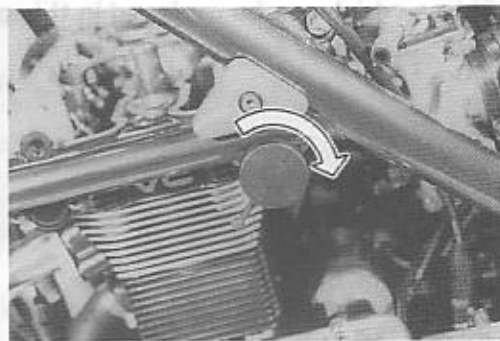
Inlet side: 0.10–0.20mm (0.004–0.008 in)

▲ CAUTION

When the HI side valve clearance is found to be within the specification, check the sub rocker arm play. (See page 24.) If the measurement is out of the specification, perform the sub rocker arm shim adjustment.

SUB ROCKER ARM SHIM ADJUSTMENT (HI SIDE)

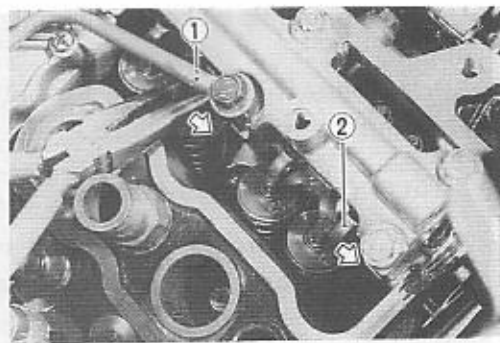
- Turn the rocker arm shaft clockwise using the special tool (Rocker shaft turning wrench) all the way until it stops.



- Slide the sub rocker arms ① and ② on the rocker arm spring side using a nose pliers, then the sub rocker arm shim can now be replaced.

NOTE:

To slide the rocker arm, apply force to the base of sub rocker arm using a nose pliers.



Shims which can be replaced in this procedure:

- Sub rocker arm shims ① and ② (two places)

- Using a magnetic pick-up tool, pull out the sub rocker arm shim.
- Replace the shim referring to the sub rocker arm shim selection table. (See page 28.)

- Turn the rocker arm shaft counterclockwise using the special tool (Rocker shaft turning wrench) all the way until it stops.
- In this condition, pull the special tool (Rocker shaft turning wrench) axially and the rocker arms for two cylinders will side together with the rocker arm shaft so that the rest of two sub rocker arm shims can be replaced.

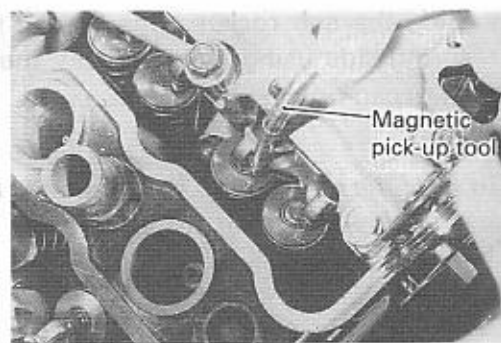
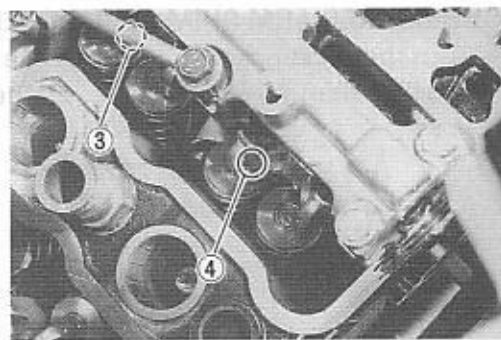
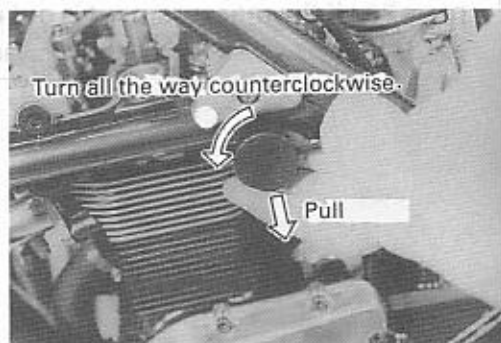
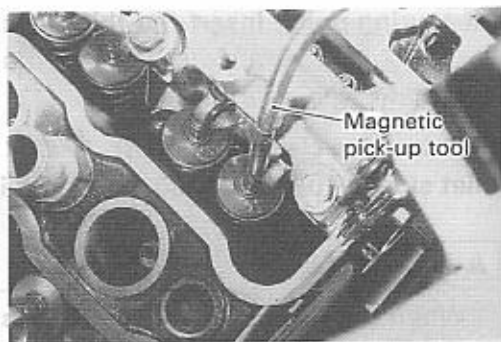
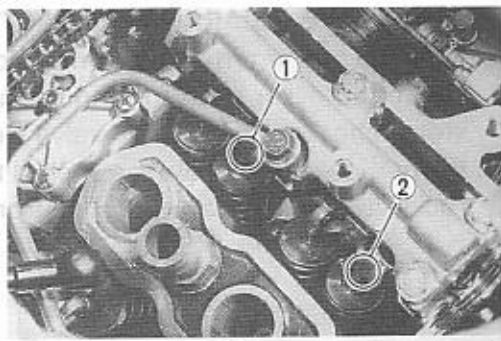
Shims which can be replaced in this procedure:

- Sub rocker arm shims ③ and ④

- Using a magnetic pick-up tool, pull out the sub rocker arm shim.
- Replace the shim referring to the sub rocker arm shim selection table. (See page 28.)

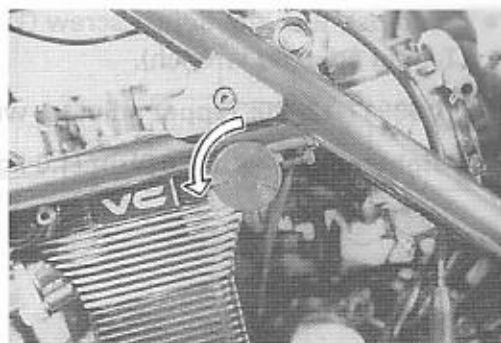
CAUTION

When the sub rocker arm shim has been replaced, make sure to check the sub rocker arm play. (See page 24.)



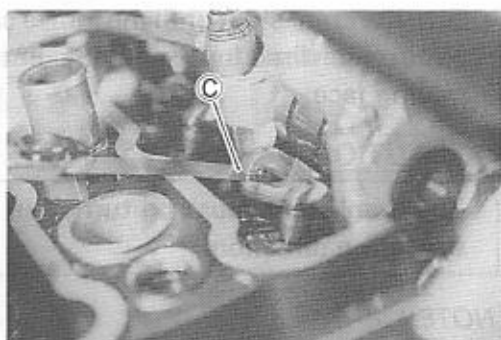
INSPECTION OF SUB ROCKER ARM PLAY

- With the rocker arm shaft turned counterclockwise using the special tool (Rocker shaft turning wrench) all the way until it stops, check for sub rocker arm play.



Measuring point: Insert the thickness gauge into the clearance © between the main rocker arm and the sub rocker arm. See page 70.

Sub rocker arm play: 0.10–0.25 mm (0.004–0.010 in)

**NOTE:**

The thickness gauge can be easily inserted when the rocker arm shaft is turned clockwise approximately 30–60 degrees.

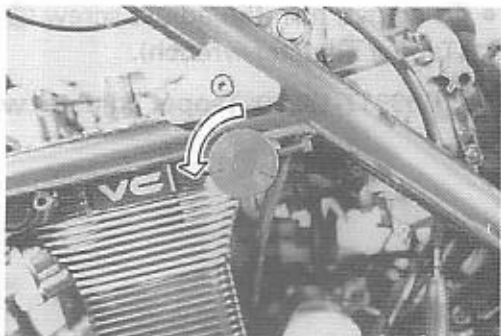
- During inspection, hold the special tool handle so that the rocker arm shaft may not move from the position turned clockwise.

**NOTE:**

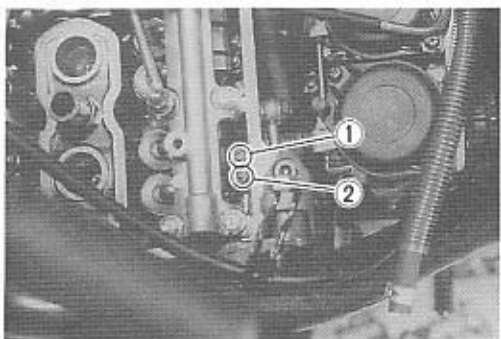
The construction of this mechanism does not allow correct inspection if the rocker arm shaft returns clockwise even slightly.

SUB ROCKER ARM PLAY ADJUSTMENT


- Turn the rocker arm shaft counterclockwise using the special tool (Rocker shaft turning wrench) all the way until it stops.
- During inspection, hold the special tool handle so that the rocker arm shaft may not move from the LO position.

**Shims which can be replaced in this procedure:**

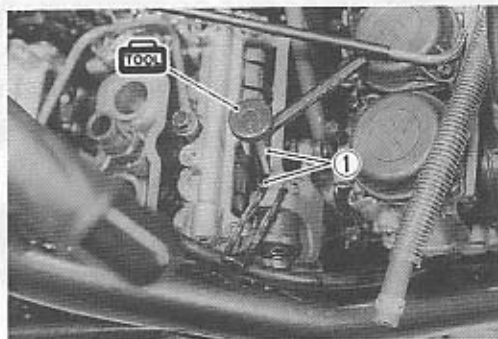
- Adjust screws ① and ② (two places)



- To adjust, turn the adjust screw ① using the special tool (Tappet adjuster wrench).

 09917-13220: Tappet adjuster wrench

-  Tightening torque: 10 N·m (1.0 kg-m, 7.0 lb-ft)



- Turn the crankshaft until the intake cam nose of #2 cylinder points the direction perpendicular to the cylinder head mating face.

CAUTION

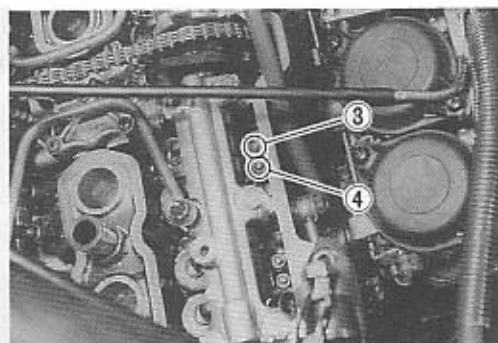
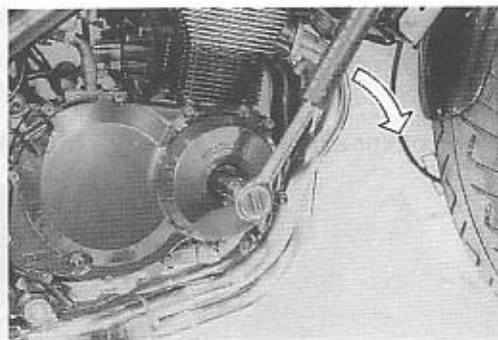
The crankshaft must be turned in the engine normal operation direction.

NOTE:

If the camshaft is not positioned as explained above, the cam nose will interfere with the tappet wrench causing the adjustment to be difficult.

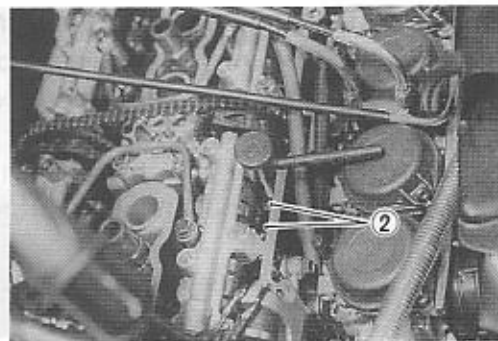
Shims which can be replaced in this procedure:

- Adjust screws ③ and ④ (two places)



- To adjust, turn the adjust screw ② using the special tool (Tappet adjuster wrench).

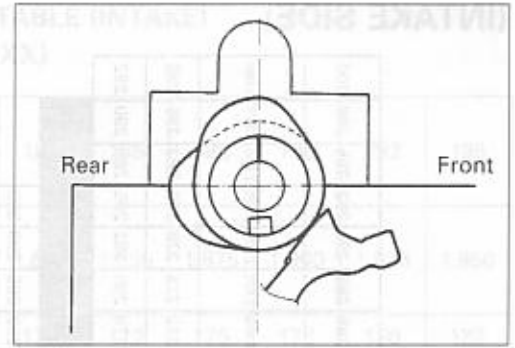
 09917-13220: Tappet adjuster wrench



INSPECTION ON #3 AND #4 CYLINDER INTAKE SIDE

- Bring the line on the intake camshaft right side end face to the position as illustrated.
- Attach the special tool (Rocker shaft turning wrench) to the rocker arm shaft being measured.

TOOL 09917-13231: Rocker shaft turning wrench



NOTE:

For valve clearance inspection and adjustment, perform the same procedure as described in "INSPECTION ON #1 AND #2 INTAKE SIDE." (See page 20.)

HOW TO USE THIS CHART

1. Measure valve clearance. *ENGINE IS COLD.
2. Measure crankpin shim gap.
3. Match clearance (vertical column) with shim.

EXAMPLE

Valve clearance is 0.17mm (0.0067").
Crankpin shim is 1.1mm (0.043").

Valve Clearance (mm)	Valve Clearance (in)	Crankpin Shim (mm)		Crankpin Shim (in)	
		Shim No.	Shim Height (mm)	Shim No.	Shim Height (in)
0.05~0.10	0.0019~0.0039	200	0.10	200	0.0039
0.11~0.16	0.0043~0.0063	190	0.09	190	0.0035
0.17~0.22	0.0067~0.0087	180	0.08	180	0.0031
0.23~0.28	0.0091~0.0111	170	0.07	170	0.0027
0.29~0.34	0.0115~0.0135	160	0.06	160	0.0023
0.35~0.40	0.0139~0.0159	150	0.05	150	0.0019
0.41~0.46	0.0163~0.0183	140	0.04	140	0.0015
0.47~0.52	0.0187~0.0207	130	0.03	130	0.0011
0.53~0.58	0.0211~0.0231	120	0.02	120	0.0007
0.59~0.64	0.0235~0.0255	110	0.01	110	0.0003

(INTAKE SIDE)

TAPPET SHIM SELECTION TABLE (INTAKE)
TAPPET SHIM NO. (12892-05C00-XXX)

SUFFIX NO.	SPECIFIED CLEARANCE/NO ADJUSTMENT REQUIRED																																								
	200	202	205	208	210	212	215	218	220	222	225	228	230	232	235	238	240	242	245	248	250	252	255	258	260	262	265	268	270	272	275	278	280	282	285	288	290	292	295	298	300
0.00~0.04	2000	2025	2050	2075	2100	2125	2150	2175	2200	2225	2250	2275	2300	2325	2350	2375	2400	2425	2450	2475	2500	2525	2550	2575	2600	2625	2650	2675	2700	2725	2750	2775	2800	2825	2850	2875	2900	2925	2950	2975	3000
0.05~0.09	200	202	205	208	210	212	215	218	220	222	225	228	230	232	235	238	240	242	245	248	250	252	255	258	260	262	265	268	270	272	275	278	280	282	285	288	290	292	295	298	300
0.10~0.20	208	210	212	215	218	220	222	225	228	230	232	235	238	240	242	245	248	250	252	255	258	260	262	265	268	270	272	275	278	280	282	285	288	290	292	295	298	300			
0.21~0.25	212	215	218	220	222	225	228	230	232	235	238	240	242	245	248	250	252	255	258	260	262	265	268	270	272	275	278	280	282	285	288	290	292	295	298	300					
0.26~0.30	218	220	222	225	228	230	232	235	238	240	242	245	248	250	252	255	258	260	262	265	268	270	272	275	278	280	282	285	288	290	292	295	298	300							
0.31~0.35	222	225	228	230	232	235	238	240	242	245	248	250	252	255	258	260	262	265	268	270	272	275	278	280	282	285	288	290	292	295	298	300									
0.36~0.40	228	230	232	235	238	240	242	245	248	250	252	255	258	260	262	265	268	270	272	275	278	280	282	285	288	290	292	295	298	300											
0.41~0.45	232	235	238	240	242	245	248	250	252	255	258	260	262	265	268	270	272	275	278	280	282	285	288	290	292	295	298	300													
0.46~0.50	238	240	242	245	248	250	252	255	258	260	262	265	268	270	272	275	278	280	282	285	288	290	292	295	298	300															
0.51~0.55	242	245	248	250	252	255	258	260	262	265	268	270	272	275	278	280	282	285	288	290	292	295	298	300																	
0.56~0.60	248	250	252	255	258	260	262	265	268	270	272	275	278	280	282	285	288	290	292	295	298	300																			
0.61~0.65	252	255	258	260	262	265	268	270	272	275	278	280	282	285	288	290	292	295	298	300																					
0.66~0.70	258	260	262	265	268	270	272	275	278	280	282	285	288	290	292	295	298	300																							
0.71~0.75	262	265	268	270	272	275	278	280	282	285	288	290	292	295	298	300																									
0.76~0.80	268	270	272	275	278	280	282	285	288	290	292	295	298	300																											
0.81~0.85	272	275	278	280	282	285	288	290	292	295	298	300																													
0.86~0.90	278	280	282	285	288	290	292	295	298	300																															
0.91~0.95	282	285	288	290	292	295	298	300																																	
0.96~1.00	288	290	292	295	298	300																																			

HOW TO USE THIS CHART:

- I. Measure tappet clearance. "ENGINE IS COLD"
- II. Measure present shim size.
- III. Match clearance in vertical column with present shim size in horizontal column.

EXAMPLE

Tappet clearance is 0.23 mm
Suffix shim No. 212
Shim size to be used 220

SUB ROCKER ARM SHIM SELECTION TABLE (INTAKE)
SHIM NO. (12845-33D00-XXX)

MEASURED CLEARANCE (mm)	SUFFIX NO.	165	168	170	172	175	178	180	182	185	188	190	192	195
	PRESENT SHIM SIZE (mm)	1.650	1.675	1.700	1.725	1.750	1.775	1.800	1.825	1.850	1.875	1.900	1.925	1.950
0.00~0.04							165	168	170	172	175	178	180	182
0.05~0.09					165	168	170	172	175	178	180	182	185	188
0.10~0.20	SPECIFIED CLEARANCE/NO ADJUSTMENT REQUIRED													
0.21~0.25		172	175	178	180	182	185	188	190	192	195			
0.26~0.30		178	180	182	185	188	190	192	195					
0.31~0.35		182	185	188	190	192	195							
0.36~0.40		188	190	192	195									
0.41~0.45		192	195											

HOW TO USE THIS CHART:

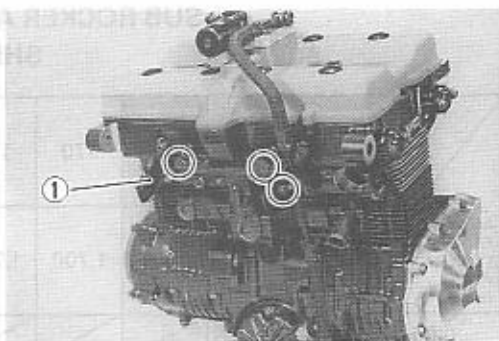
- I. Measure valve clearance. "ENGINE IS COLD"
- II. Measure present shim size.
- III. Match clearance in vertical column with present shim size in horizontal column.

EXAMPLE

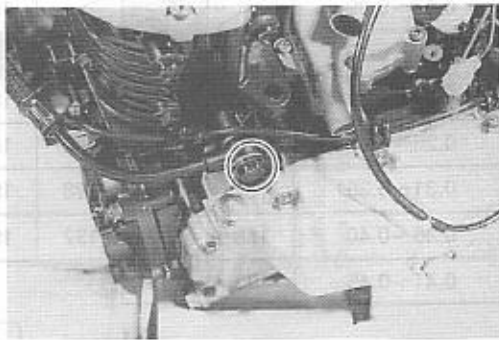
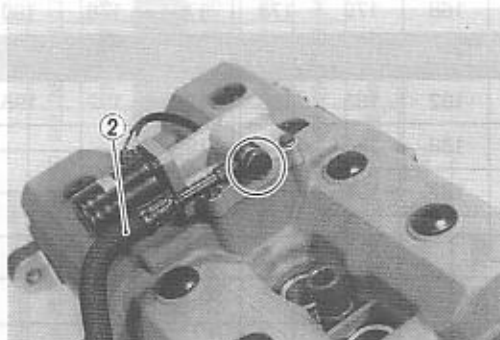
Valve clearance is 0.21 mm
 Suffix shim No. 168
 Shim size to be used 175

ENGINE DISASSEMBLY

- Remove the radiator bracket ①.



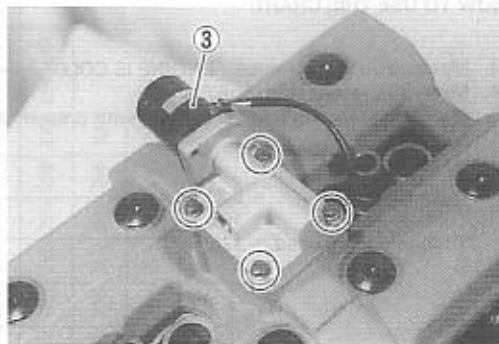
- Disconnect the oil control hose ②.



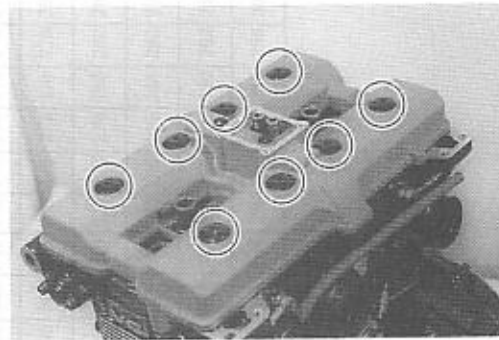
- Remove the oil control actuator ③.

CAUTION

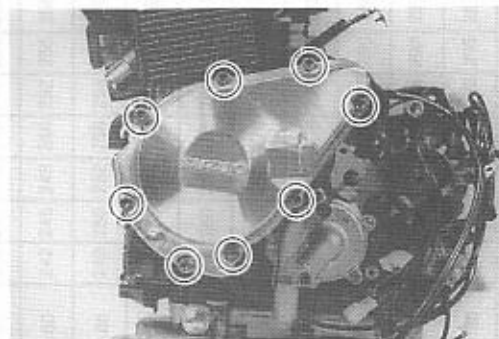
Disassembly of the oil control actuator is not permitted.



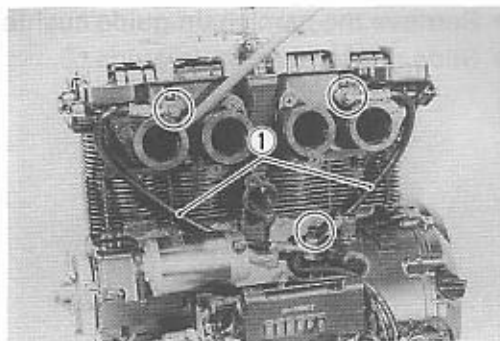
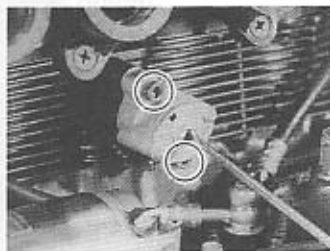
- Remove the cylinder head cover.



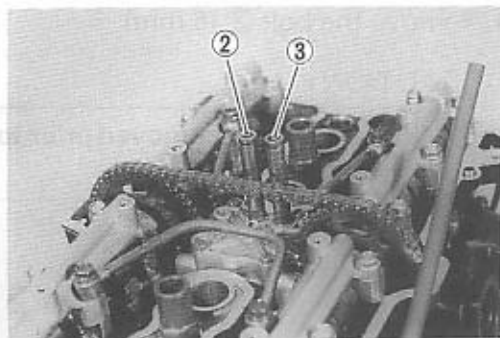
- Remove the starter gear cover.



- Remove the cam chain tensioner adjuster.
- Disconnect the oil hose ①.



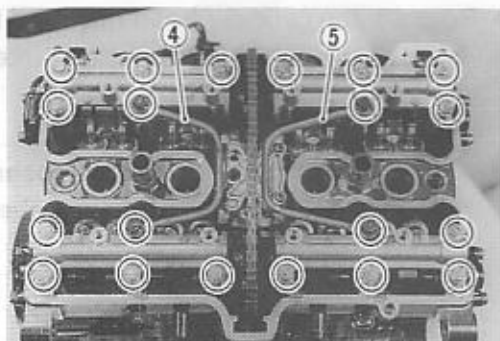
- Disconnect the VC oil line pipes ② and ③.



- Disconnect the oil pipes ④ and ⑤.
- Remove the camshaft holders.

CAUTION

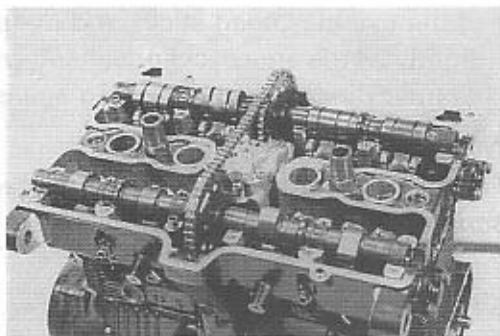
To loosen the camshaft holders, turn the bolts little by little diagonally.



- Remove the exhaust and intake camshafts.

NOTE:

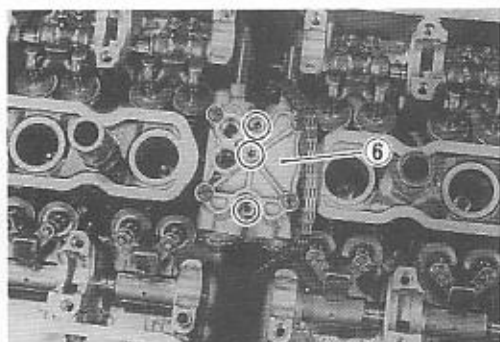
The procedure for assembling the cam sprocket is described on page 36.



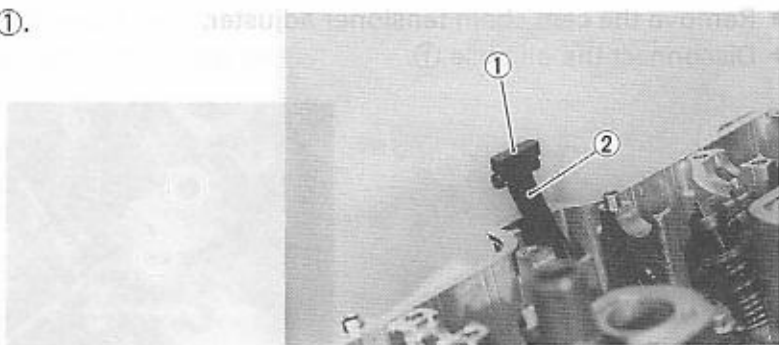
- Remove the actuator ⑥.

CAUTION

- * Care must be taken at this time because inserting the pin too deep will cause the rocker shaft to be unable to turn and the pin not to come off.
- * Insert the pin into the smaller hole of the two pin holes on the eccentric bushing.



- Remove the cam chain guide cushion ①.
- Slide off the cam chain guide ②.

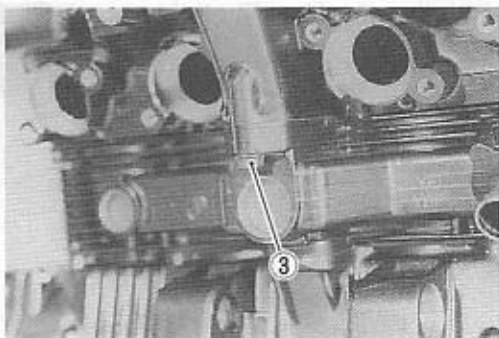


Disconnect the oil control hose ②.

- Remove the bolt ③ (6 mm).

CAUTION

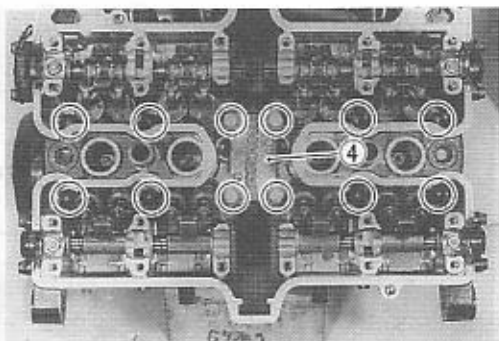
The bolt ③ must be removed prior to loosening the cylinder head nut.



- Remove the cylinder head nuts and bolts.
- Remove the actuator mounting plate ④.

CAUTION

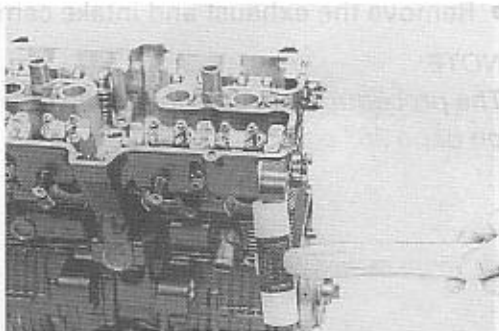
The cylinder head nut must be loosened little by little in the descending order of the numbers cast out on the cylinder head face.



- If the cylinder head sticks and does not come off easily, lightly hit the area of cylinder head without cooling fins until the cylinder head lifts using a plastic hammer.

NOTE:

For assembly and disassembly procedure, refer to the description on page 32.

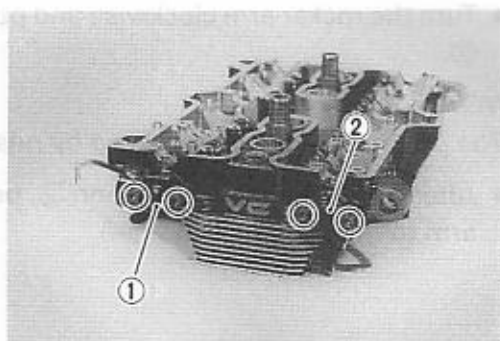


CYLINDER HEAD DISASSEMBLY (ROCKER ARM RELATED PARTS DISASSEMBLY)

- Remove the fail safe switch ①. (one place)
- Remove the cylinder head side cap ②. (three places)

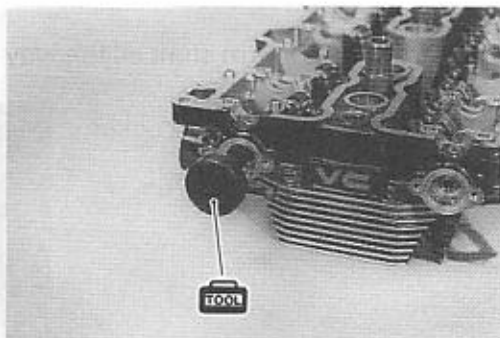
NOTE:

For disassembly and assembly of exhaust side rocker arm, refer to GSF400 Service Manual.

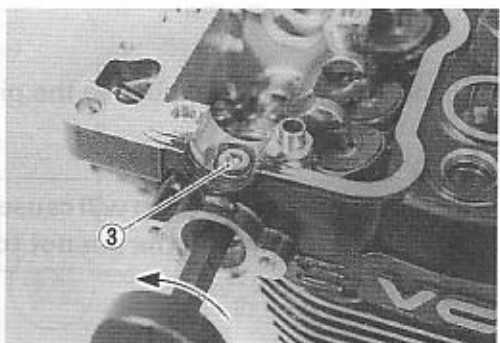


- Install the special tool (Rocker shaft turning wrench) on the rocker arm shaft.

TOOL 09917-13231: Rocker shaft turning wrench



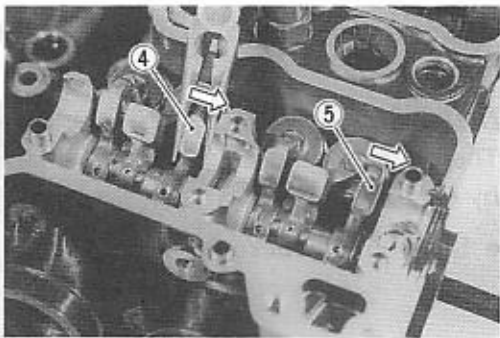
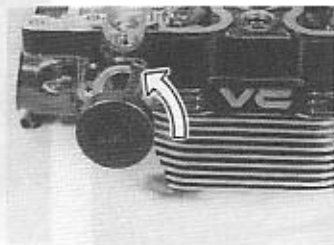
- Remove the rocker arm shaft tightening screw ③.
- Loosen the sub rocker arm adjust screw.



- Turn the sub rocker arm shaft counterclockwise all the way.
- Slide the sub rocker arms ④ and ⑤ toward the spring.

NOTE:

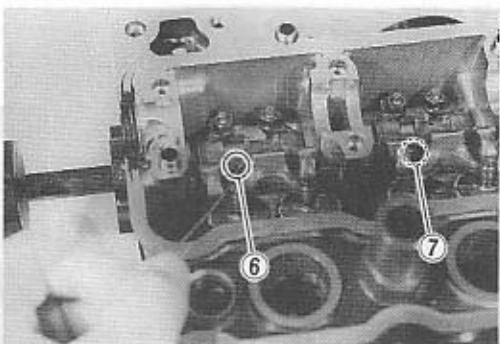
To slide the rocker arm, apply force to the base of sub rocker arm using a nose pliers.



- Using a piece of wire, push the pins ⑥ and ⑦ 2-3 mm (0.08-0.12 in) inside.

▲ CAUTION

- * Care must be taken at this time because inserting the pin too deep will cause the rocker shaft to be unable to turn and the pin not to come off.
- * Insert the pin into the smaller hole of the two pin holes on the eccentric bushing.

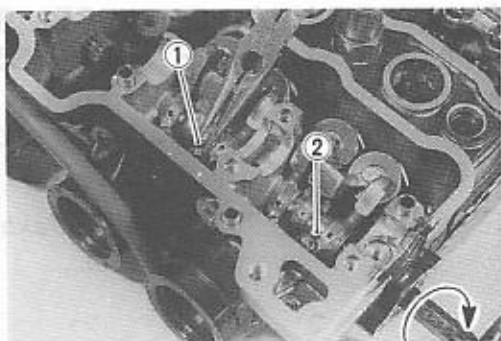


- Turn the rocker arm clockwise and pull out the pins ① and ②.

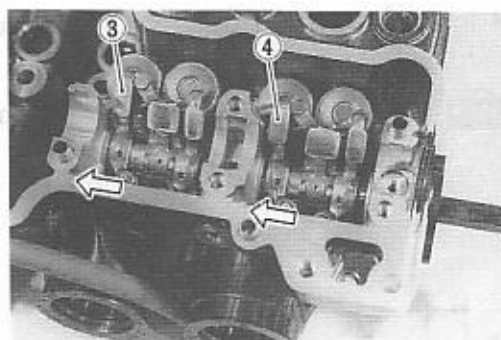
NOTE:

The pin may be easily removed by nose pliers.

- After removing the pins ① and ②, position the sub rocker arm to the original condition.



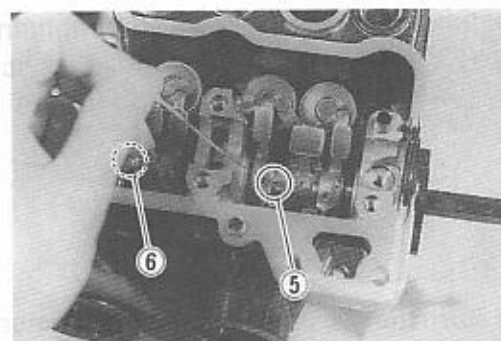
- Turn the rocker arm shaft all the way clockwise and pull on the shaft.
- Slide the inside sub rocker arms ③ and ④.



- Using a piece of wire, push in the pins ⑤ and ⑥ 2-3mm.

CAUTION

Inserting the pin too deep will cause the rocker shaft to be unable to turn and the pin not to come off.

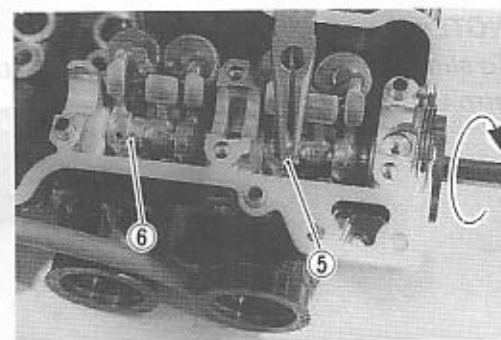
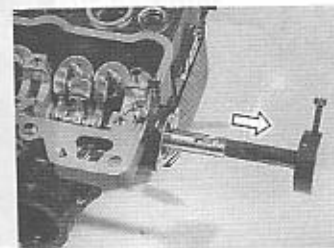


- Turn the rocker arm clockwise and pull out the pins ⑤ and ⑥.

NOTE:

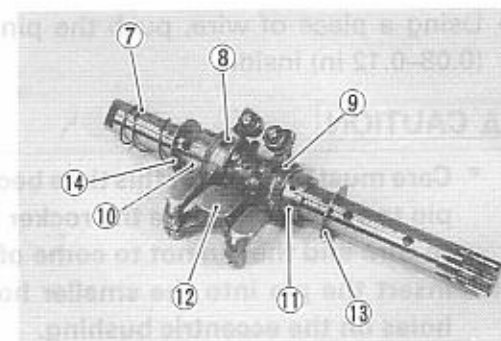
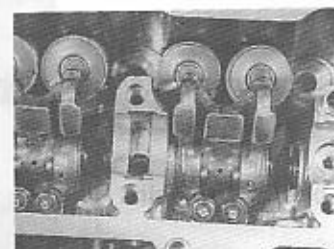
The pin may be easily removed by nose pliers.

- Slide out the rocker arm shaft.



- Disassemble the following parts:

- Spring ⑦
- Sub rocker arms ⑧ and ⑨
- Eccentric bushings ⑩ and ⑪
- Main rocker arm ⑫
- Washers ⑬ and ⑭

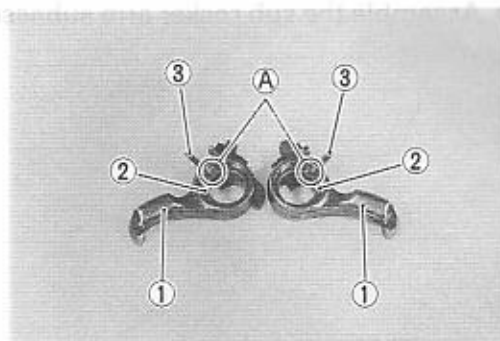


CYLINDER HEAD ASSEMBLY (ROCKER ARM RELATED PARTS ASSEMBLY)

- Fit the eccentric bushing ② into the sub rocker arm ① and insert the pin ③.
- Screw in the sub rocker arm adjust screw by approximately three complete turns and tighten temporarily.

CAUTION

- * Assemble the eccentric bushing with its groove **A** on the side opposite to the main rocker arm.
- * Do not allow the pin to protrude from the eccentric bushing inner surface.

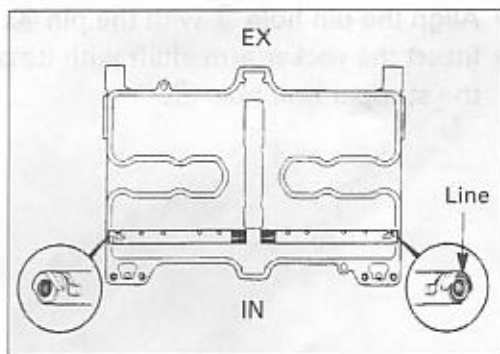


CAUTION

Two intake rocker arm shafts are each different and therefore do not confuse one with the other.

NOTE: The rocker arm shafts can be identified by checking for a grooved line:

- With line — Intake RH side
- Without line — Intake LH side



- Fit the special tool (Rocker shaft turning wrench) to the rocker arm shaft.

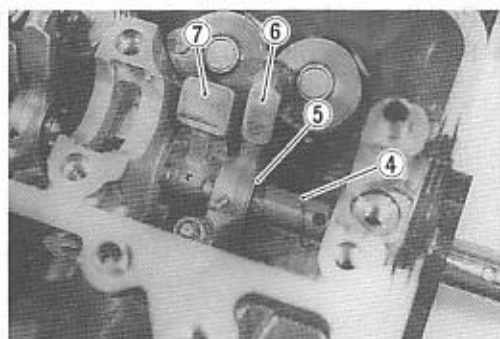
TOOL 09917-13231: Rocker shaft turning wrench



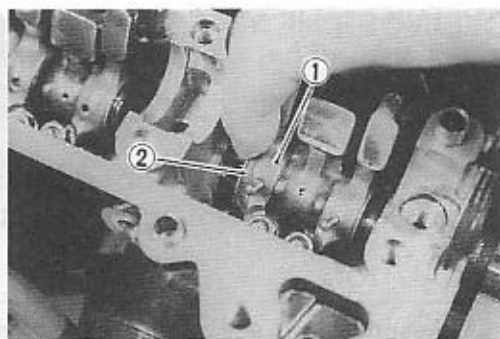
- While sliding in the rocker shaft, assemble the spring ④ washer ⑤, sub rocker arm subassembly (outside) ⑥ and main rocker arm ⑦.

CAUTION

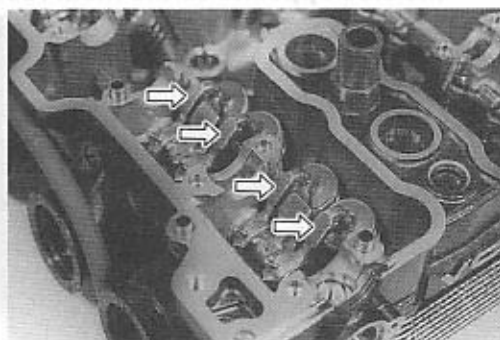
Do not confuse the right sub rocker arm with the left one since they are different in dimensions.



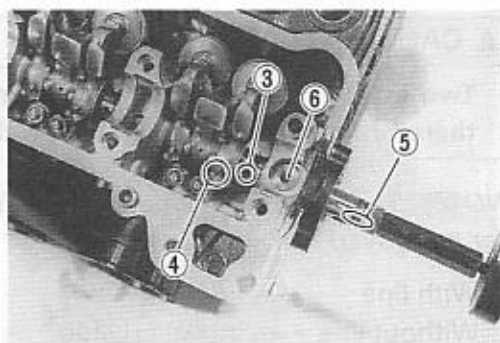
- Assemble the sub rocker arm subassembly (inside) ① and washer ②.



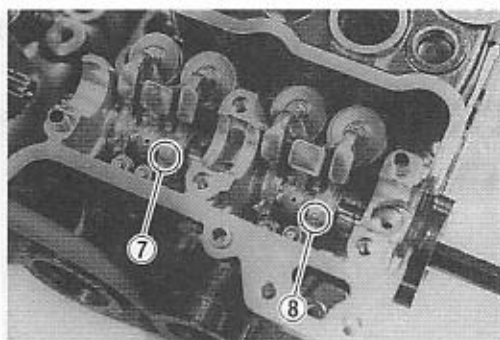
- Depress the main and sub rocker arms.



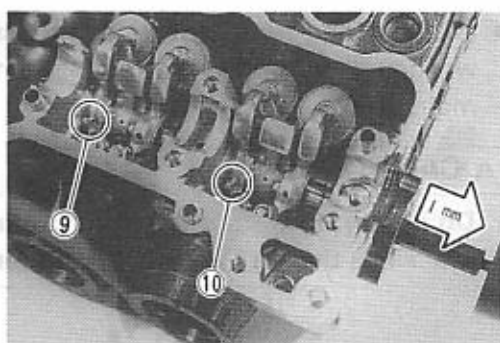
- Align the pin hole ③ with the pin ④.
- Insert the rocker arm shaft with its center ⑤ aligned with the stopper bolt hole ⑥.




- Press in the pins ⑦ and ⑧.

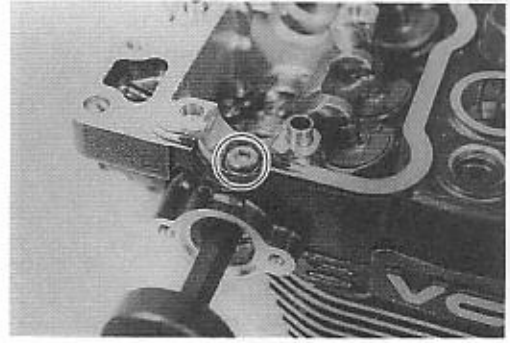


- Pull the rocker arm shaft by approximately 1 mm (0.04 in).
- Press in the pins ⑨ and ⑩.



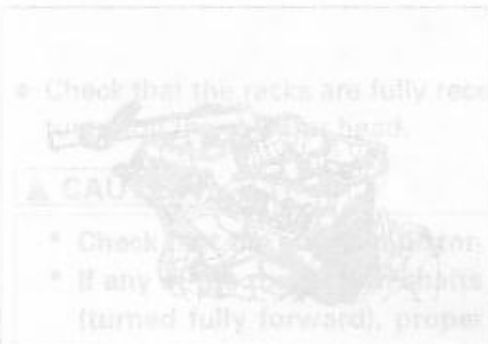
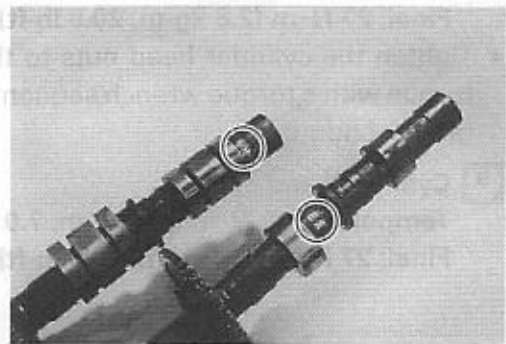
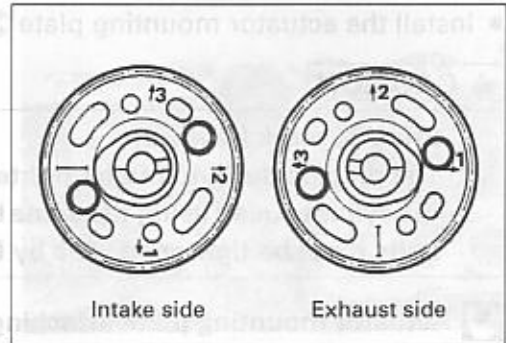
- Temporarily tighten the rocker arm shaft stopper bolt and check that the rocker arm shaft turns smoothly between LO and HI positions.
- Tighten the rocker arm shaft stopper bolt to the specified torque.

 **Tightening torque: 11 N·m (1.1 kg-m, 8.0 lb-ft)**



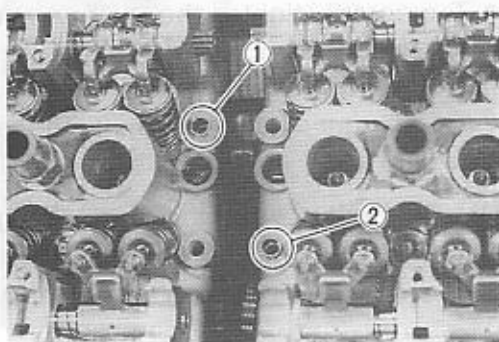
CAM SPROCKET INSTALLATION

- The cam sprocket installing position is determined by the relative position between the arrows 1, 2 and 3 on the sprockets and the camshaft cutaway or grooved line. Refer to the illustration when installing.



ENGINE ASSEMBLY

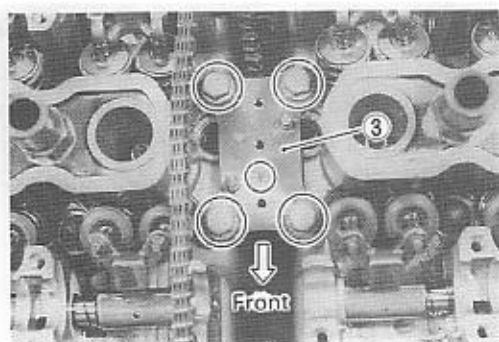
- Fit the dowel pins ① and ②.



- Install the actuator mounting plate ③.

CAUTION

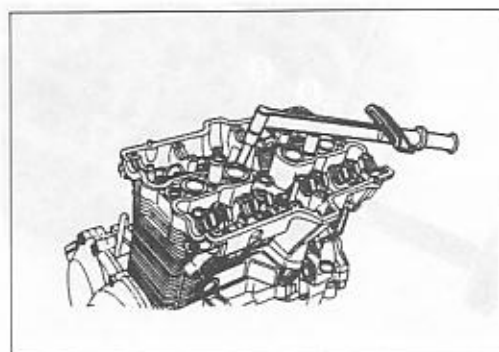
- * Bring Δ mark forward.
- * The plate is designed to be tightened together with the cylinder head using the same bolt. Therefore, the bolts must be tightened little by little diagonally.



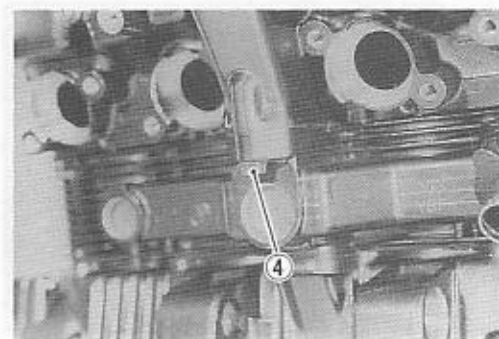
- Actuator mounting plate attaching bolt
Temporary: 10 N·m (1.0 kg-m, 7.0 lb-ft)
Final: 27 N·m (2.8 kg-m, 20.0 lb-ft)

- Tighten the cylinder head nuts to the specified two-step torque with a torque wrench sequentially in the ascending order of numbers.

- Cylinder head nut
Temporary: 10 N·m (1.0 kg-m, 7.0 lb-ft)
Final: 27 N·m (2.8 kg-m, 20.0 lb-ft)



- Tighten the 6 mm bolt ④ on the front area of engine.

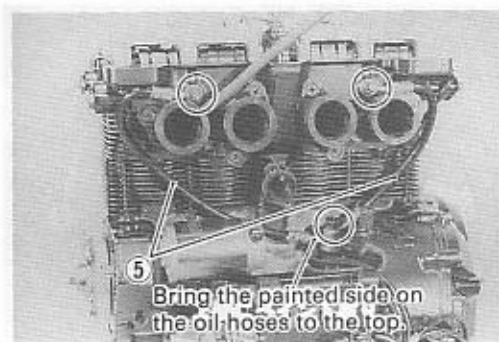


- Install the oil hose ⑤.

CAUTION

- * Do not confuse the length of hoses between the right and the left as they are different.
- * Do not fail to install the gasket.

- Oil hose bolt
Upper: 20 N·m (2.0 kg-m, 14.5 lb-ft)
Lower: 27 N·m (2.8 kg-m, 20.0 lb-ft)



- After ascertaining that the cam chain and crankshaft sprocket are securely engaged, slide in the cam chain guide ①.

▲ CAUTION

The cam chain guide lower end must be securely fitted with the lower crankcase and the upper end with the cylinder head.

- Fit the cam chain guide cushion ②.

▲ CAUTION

The grooved side must face down.

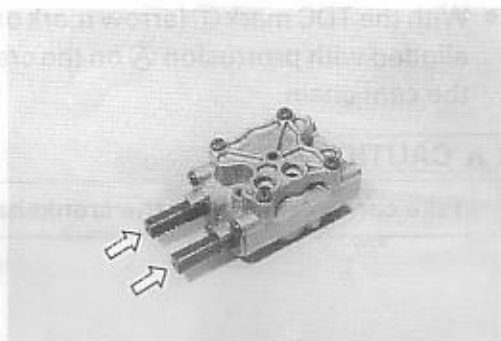
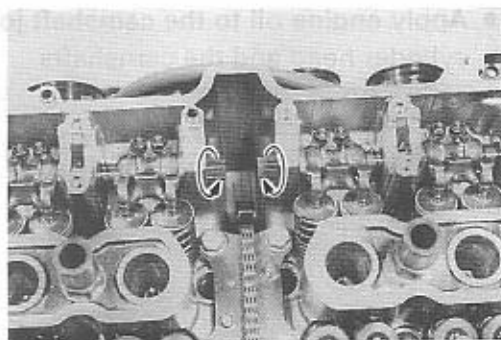
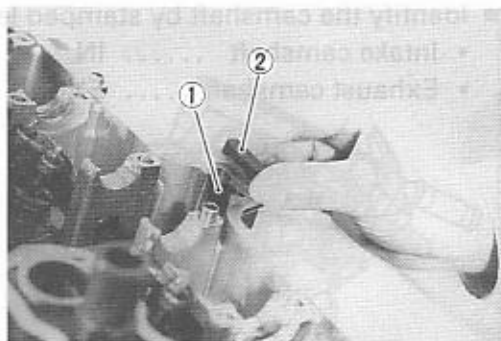
- Loosen all the sub rocker arm adjust screws (eight in total).
- Turn the rocker arm shafts forward (LO position).
- LO position can be confirmed when the rocker arm shaft slides with the special tool pulled outside.



- Check that the racks are fully retracted, then install the actuator on the cylinder head.

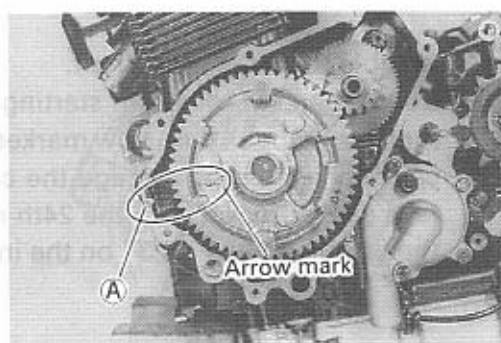
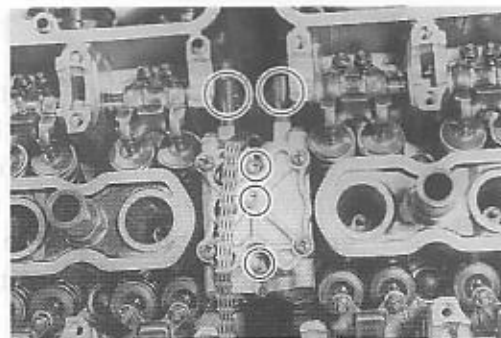
▲ CAUTION

- * Check that the actuator piston operation is smooth.
- * If any of the rocker arm shafts is out of LO position (turned fully forward), proper assembly operation can not be expected.
- * Check that the rocker arm shaft gear is engaged with the actuator rack.



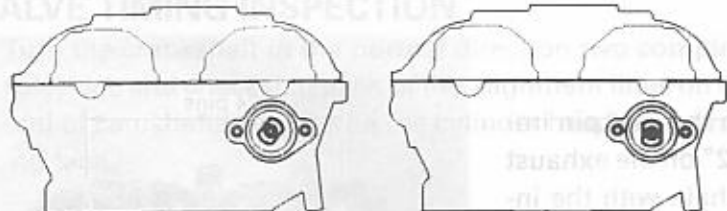
🔧 Actuator bolt: 7.0 N·m (0.7 kg-m, 5.0 lb-ft)

- After completing the actuator assembly, check that the rocker arm shaft can take both LO and HI positions with the shaft turned.



Low position

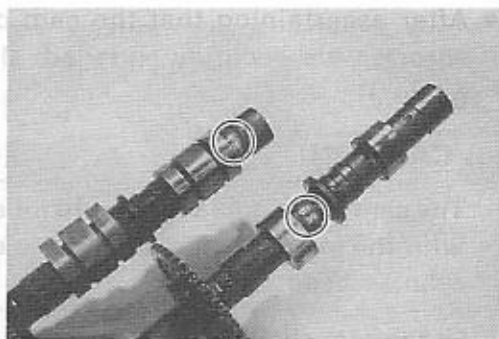
Hi position



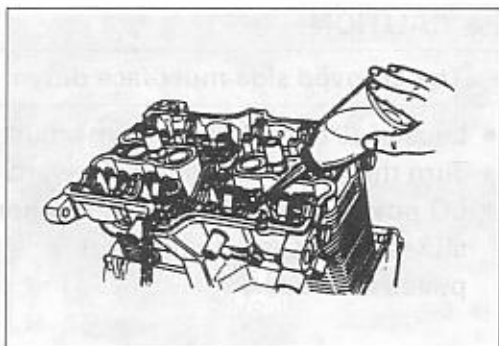
- Turn the crankshaft to the position where #1 and #4 pistons come to TDC.
 - Align the TDC mark ① (Arrow mark) with the crankcase protrusion ②.

- Identify the camshaft by stamped letter.

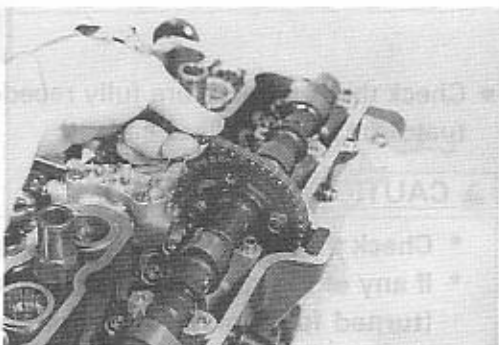
- Intake camshaft IN
- Exhaust camshaft EX



- Apply engine oil to the camshaft journal bearings on the cylinder head and the camshafts.



- With the TDC mark ⊕ (arrow mark on the signal generator) aligned with protrusion ⊕ on the crankcase, lightly pull on the cam chain.

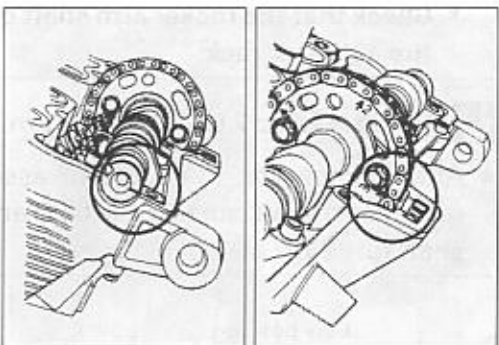


CAUTION

Take care not to allow the crankshaft to turn.

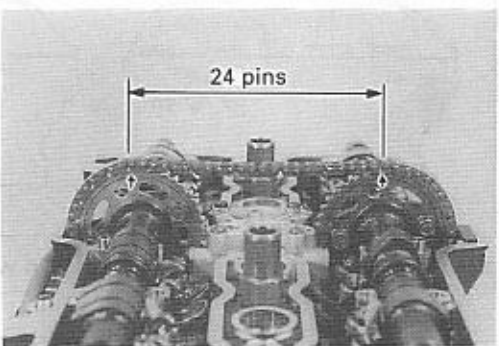
- Assemble the exhaust camshaft.

- Position the exhaust camshaft with its alignment line on the end face pointing forward of the engine and parallel with the cylinder head cover mating face.
- Position the exhaust camshaft so that the arrow marked "↑ 1" on the cam sprocket points the plane of the cylinder head upper face and engage the cam chain with the cam sprocket.



- Assemble the intake camshaft.

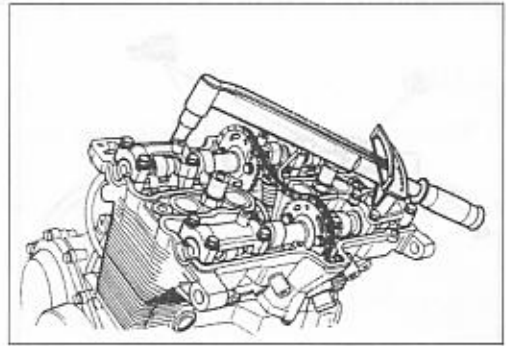
- Count the 24th roller pin starting from the first pin immediately above the arrow marked "↑ 2" on the exhaust camshaft sprocket. Engage the cam chain with the intake cam sprocket with the 24th roller pin aligned with the arrow marked "↑ 3" on the intake cam sprocket.




- Apply engine oil to the camshafts and journal bearings.
- Install the camshaft holders.
 - Identify the camshaft holders by the code (A)(B)(C)(D) shown and assemble them referring to the photograph.

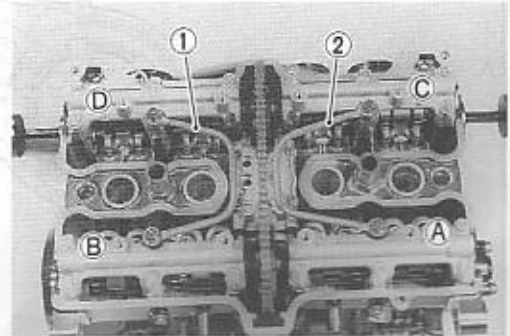
▲ CAUTION

Take care not to allow the crankshaft and exhaust camshaft to turn.

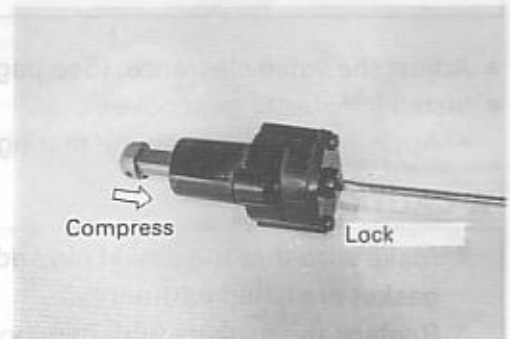


- Install the oil pipes ① and ②.
 - Tighten together with the camshaft holders.
 - Fit the washers above the oil pipe joints.


 Camshaft holder tightening bolt: 10 N·m
(1.0 kg-m, 7.0 lb-ft)



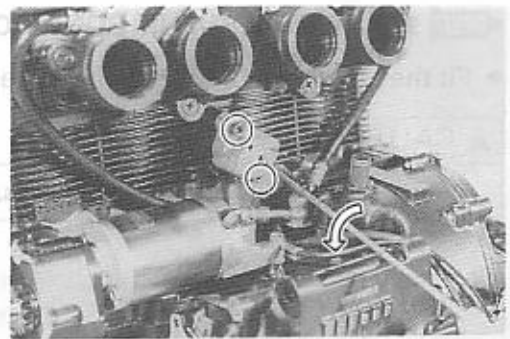
- Using a plain screwdriver, compress the cam chain tensioner adjuster push rod. With the push rod contracted, lock it by turning the screwdriver all the way in.



- Install the cam chain tensioner adjuster on the cylinder.

 Cam chain tensioner adjuster: 7.0 N·m
(0.7 kg-m, 5.5 lb-ft)

- Return the push rod using a plain screwdriver.

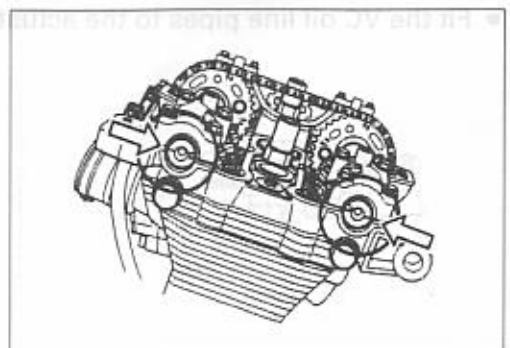


VALVE TIMING INSPECTION

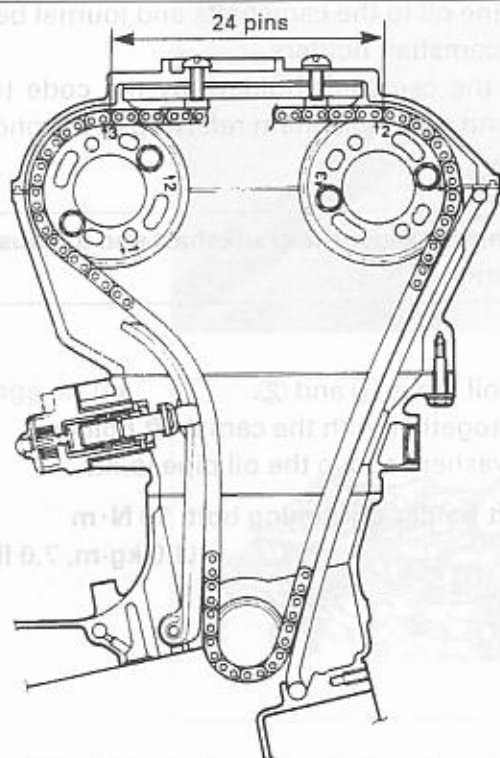
- Turn the crankshaft in the normal direction two complete rotations and check that each of the alignment lines on the end of camshafts aligns with the cylinder head cover mating face.

▲ CAUTION

Do not attempt to reverse the crankshaft or it may possibly result in wrong valve timing or deformation of chain guide.



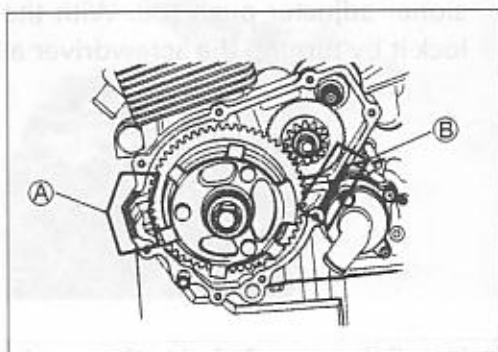
Align



- Adjust the valve clearance. (See page 19.)
- Install the starter gear cover.
 - Apply liquid gasket on the mating faces (A) and (B).

CAUTION

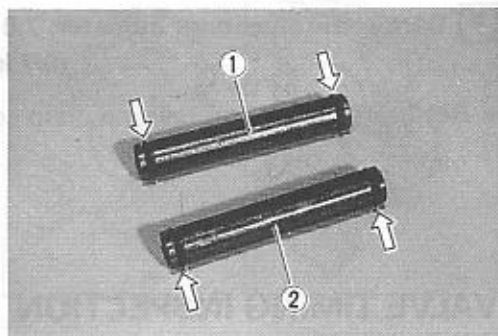
- * Make sure that the dowel pin and starter gear cover gasket are fitted without fail.
- * Replace the gaskets with new ones.

**1207B** 99000-31140: SUZUKI BOND NO. 1207B

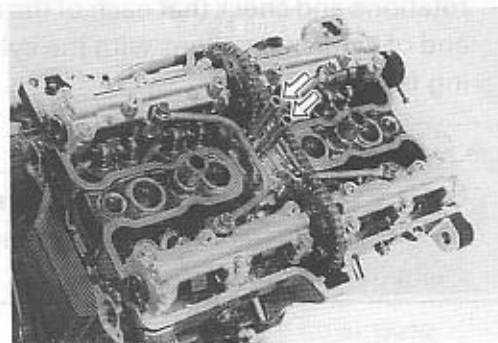
- Fit the O-ring on the VC oil line pipes ① and ②.

CAUTION

Replace the O-rings with new ones.




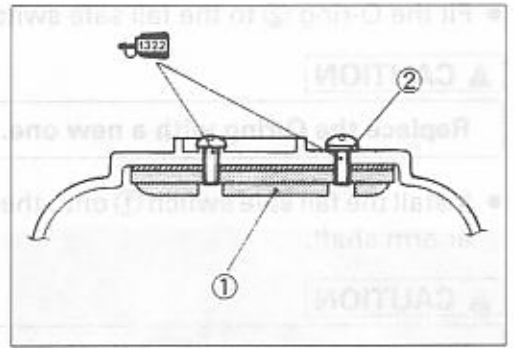
- Fit the VC oil line pipes to the actuator.



- Install the cam chain No.2 guide ① on the cylinder head cover.
- Use the gasket ② without fail.
- Apply thread lock to the attaching screws.

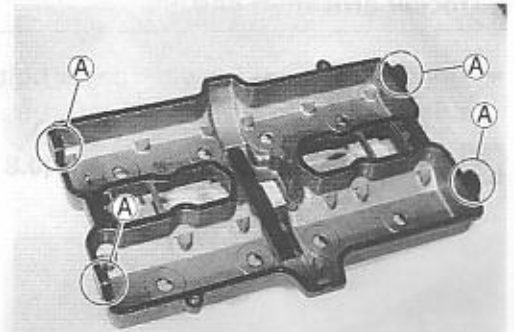
 99000-32050: THREAD LOCK "1322"

 Cam chain guide: 3 N·m (0.3 kg-m, 2.0 lb-ft)

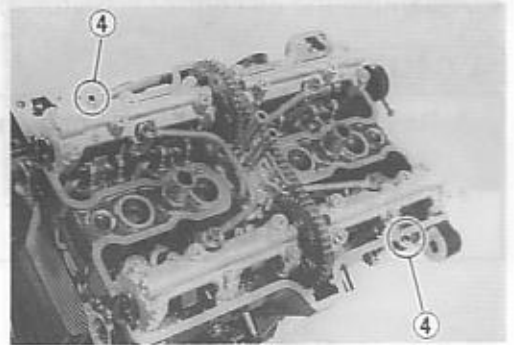


- Position the new gasket on the cylinder head cover.
- Apply liquid gasket to the four cam end caps shown as (A).

 99000-31140: SUZUKI BOND NO. 1207B




- Fit the dowel pin ④ on the cylinder head cover.
- Apply engine oil to each camshaft oil pocket.

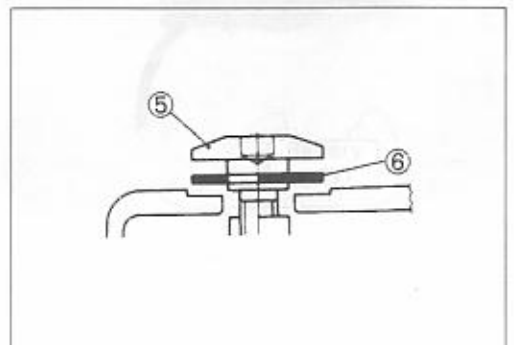
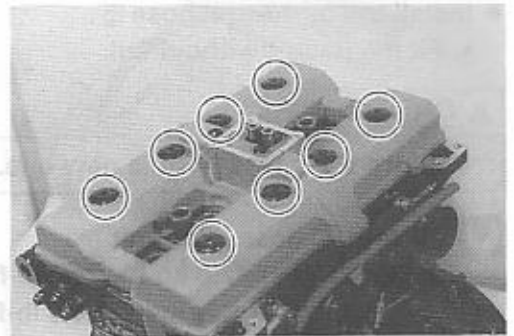


- Install the cylinder head cover.
 - The cylinder head cover attaching bolts must be tightened evenly starting from inside in a diagonal fashion.
- Coat engine oil on the sealing surface of the gasket ⑥.
- Fit the gasket ⑥ to the cylinder head cover bolt ⑤ and tighten the bolt to the specified torque.

CAUTION

The gasket must be replaced with new one.

 Cylinder head cover bolt: 10 N·m (1.0 kg-m, 7.0 lb-ft)



- Fit the O-ring ② to the fail safe switch ①.

CAUTION

Replace the O-ring with a new one.

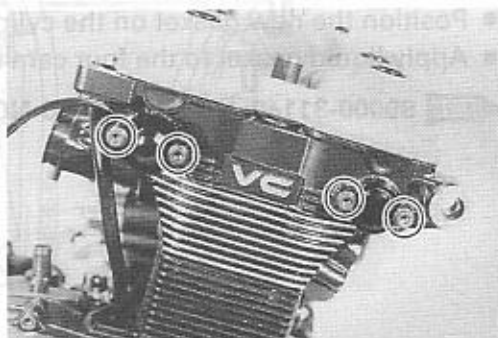
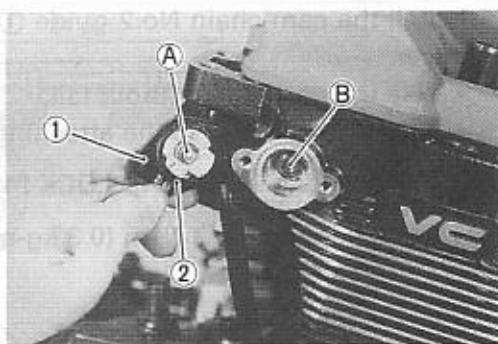
- Install the fail safe switch ① onto the intake right side rocker arm shaft.

CAUTION

Engage the groove A of the fail safe switch with the rocker arm shaft end B.

- Tighten the fail safe switch cover bolt and the cylinder head side cap bolt to the specified torque.

Oil control hose joint bolt: 8.0 N·m (0.8 kg-m, 6.0 lb-ft)

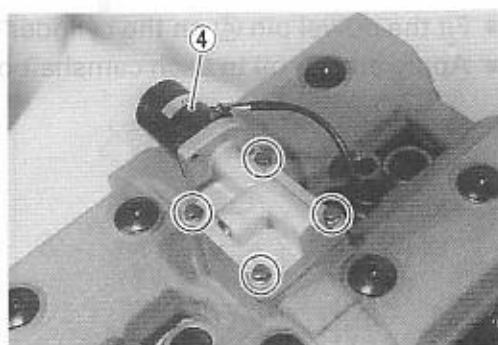


- Assemble the oil control actuator ④.

CAUTION

* Do not attempt to disassemble the oil control actuator.

* The oil control actuator gasket must be installed with its bead facing down.

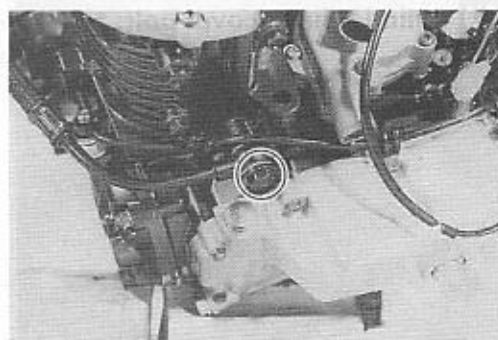
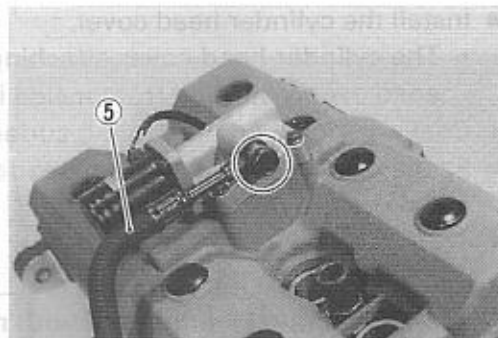


- Install the oil control hose ⑤.
- Fit the gasket without fail.

CAUTION

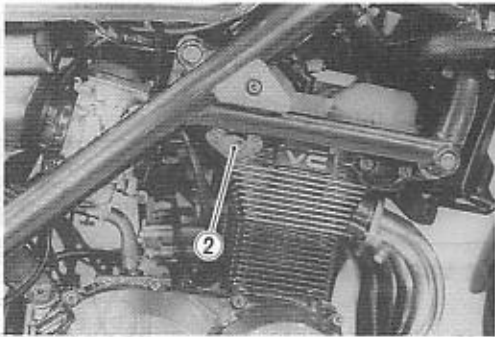
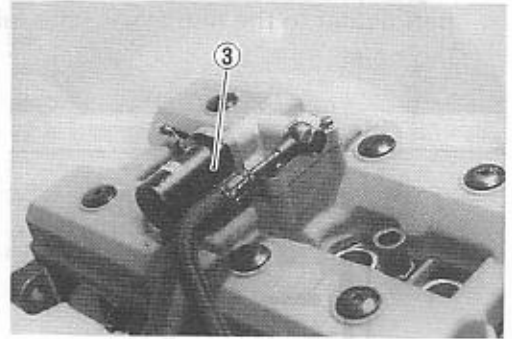
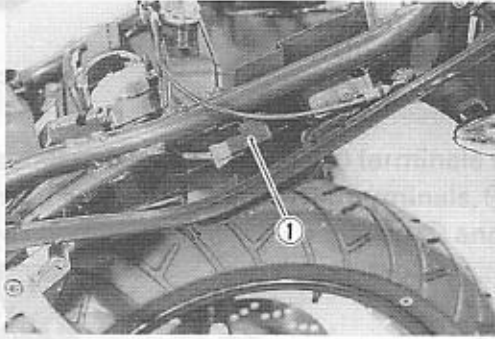
Replace the gasket with a new one.

Oil control hose joint bolt
Upper: 28 N·m (2.8 kg-m, 21.0 lb-ft)
Lower: 28 N·m (2.8 kg-m, 21.0 lb-ft)




LOCATION OF ELECTRICAL PARTS

- ① Ignitor
- ② Fail safe switch
- ③ Oil control actuator solenoid
- ④ Ignitor unit



OIL CONTROL ACTUATOR SOLENOID INSPECTION

- Check for the coil resistance using a circuit tester.

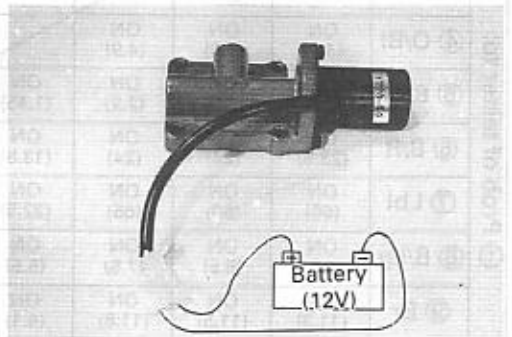
 Tester knob indication: $\times 1\Omega$ range

Actuator solenoid resistance: 14.2–15.2 Ω

- Check that the piston operates properly when 12V voltage is applied to the oil control actuator lead wire.

NOTE:

If a click sound is heard when 12V voltage is applied, the piston is operating properly.



VC MECHANISM TROUBLESHOOTING

INSUFFICIENT POWER AT LOW AND MID SPEED

Start engine and check if two rocker arm shafts are on low speed side during idling.

Shafts are on low speed side.

Shafts are not on low speed side.

Electrical system failure

- Oil control actuator (solenoid) failure
- Ignitor failure

Rocker arm shaft operation failure

- Foreign substance sticking, dent or scratch
- Rack & pinion improperly set
- Sub rocker arm play improperly adjusted

VC actuator operation failure

- Insufficient oil pressure from engine
- Oil pipe O-ring damaged
- Actuator piston not sliding properly

Improper valve clearance adjustment

NOT REACHING HIGH SPEED AND POWER INSUFFICIENT

Check if switching sound can be heard at 9 000 rpm with transmission in gear other than neutral.

Switching sound is heard.

Switching sound is not heard.

- * Use care for safety since inspection is at high speed. Squeeze clutch lever and apply both front and rear brakes securely. Inspection must be done in a short period of time.

Electrical system failure

- Oil control actuator (solenoid) failure
- Gear shift switch failure
- Ignitor failure

- * Rocker arm shaft operation must be checked by two persons.

Check if two rocker arm shafts are both on high speed side.

Shafts are on high speed side.

Shafts are not on high speed side.

Rocker arm shaft operation failure

- Foreign substance sticking, dent or scratch
- Rack & pinion improperly set

VC actuator operation failure

- Insufficient oil pressure from engine
- Oil pipe O-ring damaged
- Actuator piston not sliding properly

- Improper valve clearance adjustment
- Fail safe switch failure
- Ignitor failure

ABNORMAL SWITCHING SOUND OCCURS DURING RUNNING

Switching sound persists.

- Electrical system failure
 - Oil control actuator (solenoid) failure
- Rocker arm shaft operation failure
 - Foreign substance sticking, dent or scratch
 - Rack & pinion improperly set
- VC actuator operation failure
 - Insufficient oil pressure from engine
 - Oil pipe O-ring damaged
 - Actuator piston not sliding properly

Switching sound occurs at revolutions other than 9 000 rpm.

- Electrical system failure
 - Oil control actuator (solenoid) failure
 - Ignitor failure

TAPPET NOISE TOO LOUD

Check if tappet clearance and sub rocker arm play are within specification.

Normal

Beyond specification

Adjust tappet clearance and sub rocker arm play.

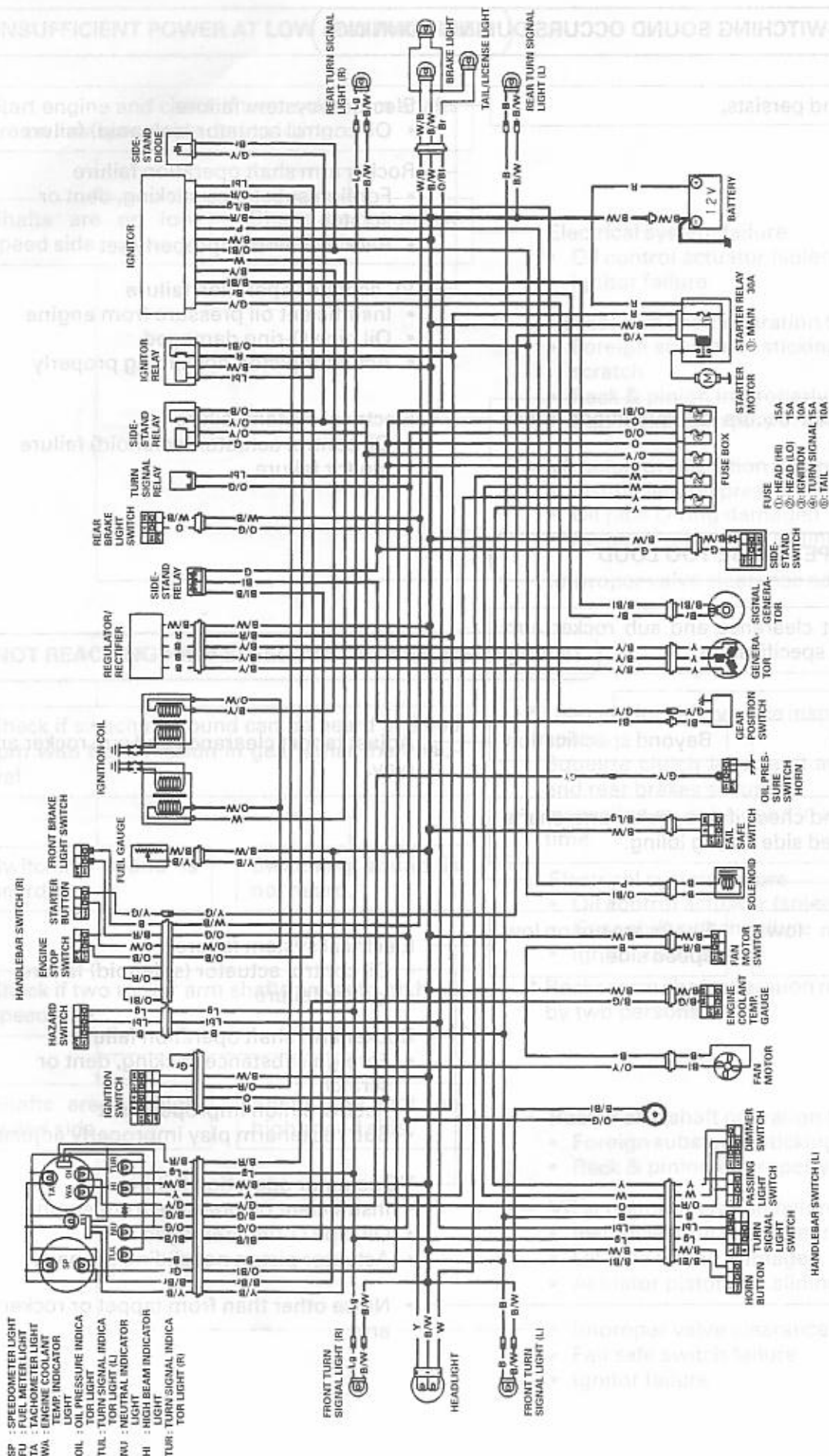
Start engine and check if two rocker arm shafts are on low speed side during idling.

Shafts are on low speed side.

Shafts are not on low speed side.

- Electrical system failure
 - Oil control actuator (solenoid) failure
 - Ignitor failure
- Rocker arm shaft operation failure
 - Foreign substance sticking, dent or scratch
 - Rack & pinion improperly set
 - Sub rocker arm play improperly adjusted
- VC actuator operation failure
 - Insufficient oil pressure from engine
 - Oil pipe O-ring damaged
 - Actuator piston not sliding properly
- Noise other than from tappet or rocker arm

WIRING DIAGRAM



- SP : SPEEDOMETER LIGHT
- FU : FUEL METER LIGHT
- TA : TACHOMETER LIGHT
- WA : ENGINE COOLANT TEMP INDICATOR LIGHT
- OIL : OIL PRESSURE INDICATOR LIGHT
- TUL : TURN SIGNAL INDICATOR LIGHT
- NI : NIGHT LIGHT
- HI : HIGH BEAM INDICATOR LIGHT
- TUR : TURN SIGNAL INDICATOR LIGHT

- WIRE COLOR**
- B : Black
 - Bl : Blue
 - Br : Brown
 - Lbl : Light blue
 - Lg : Light green
 - G : Green
- Gr** : Gray
- R** : Red
- O** : Orange
- P** : Pink
- W** : White
- Y** : Yellow
- B/Bl** : Black with Blue tracer
- B/Br** : Black with Brown tracer
- B/G** : Black with Green tracer
- B/Lg** : Black with Light green tracer
- B/R** : Black with Red tracer
- B/W** : Black with White tracer
- B/Y** : Black with Yellow tracer
- O/R** : Orange with Red tracer
- O/W** : Orange with White tracer
- O/Y** : Orange with Yellow tracer
- W/B** : White with Black tracer
- Y/B** : Yellow with Black tracer
- Y/G** : Yellow with Green tracer
- B/Y** : Black with Yellow tracer
- Bl/B** : Blue with Black tracer
- G/Y** : Green with Yellow tracer
- O/B** : Orange with Black tracer
- O/Bl** : Orange with Blue tracer
- O/G** : Orange with Green tracer

HANDLEBAR SWITCH (L)

FUSE BOX

STARTER RELAY

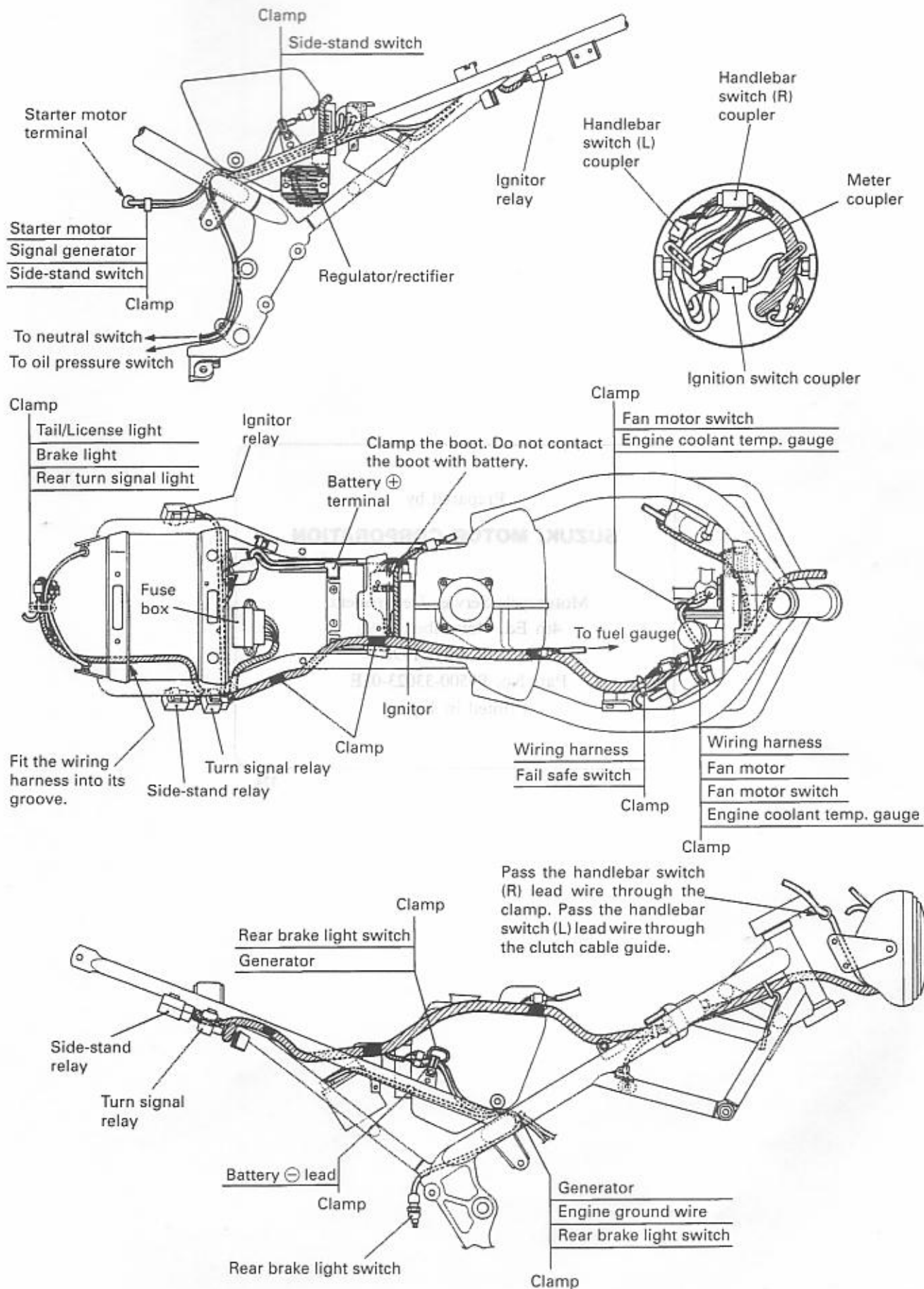
BATTERY

INSUFFICIENT POWER AT LOW RPM

ABNORMAL SWITCHING SOUND OCCURS

NOT REACT

WIRE HARNESS ROUTING



Prepared by

SUZUKI MOTOR CORPORATION

Motorcycle Service Department

3rd Ed. February, 1993

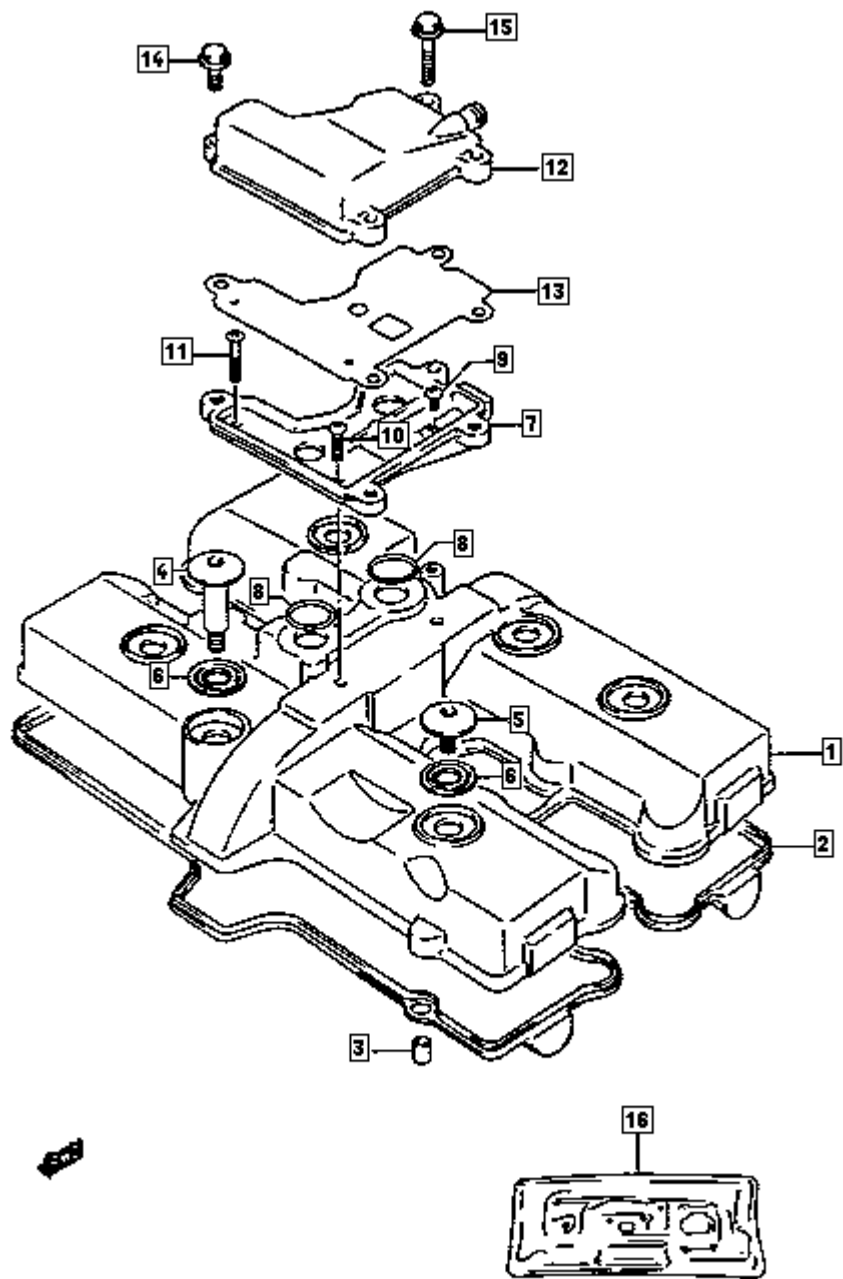
1st Ed. July, 1990

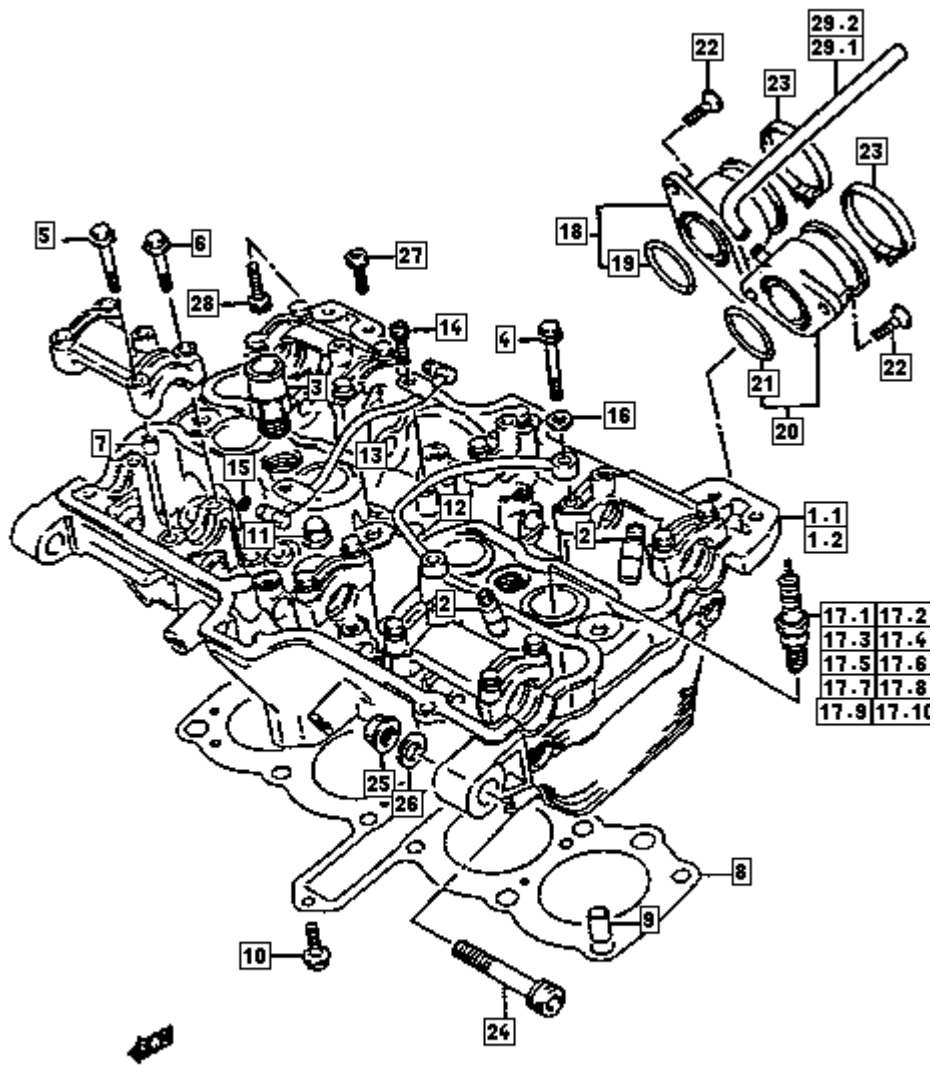
Part No. 99500-33022-03E

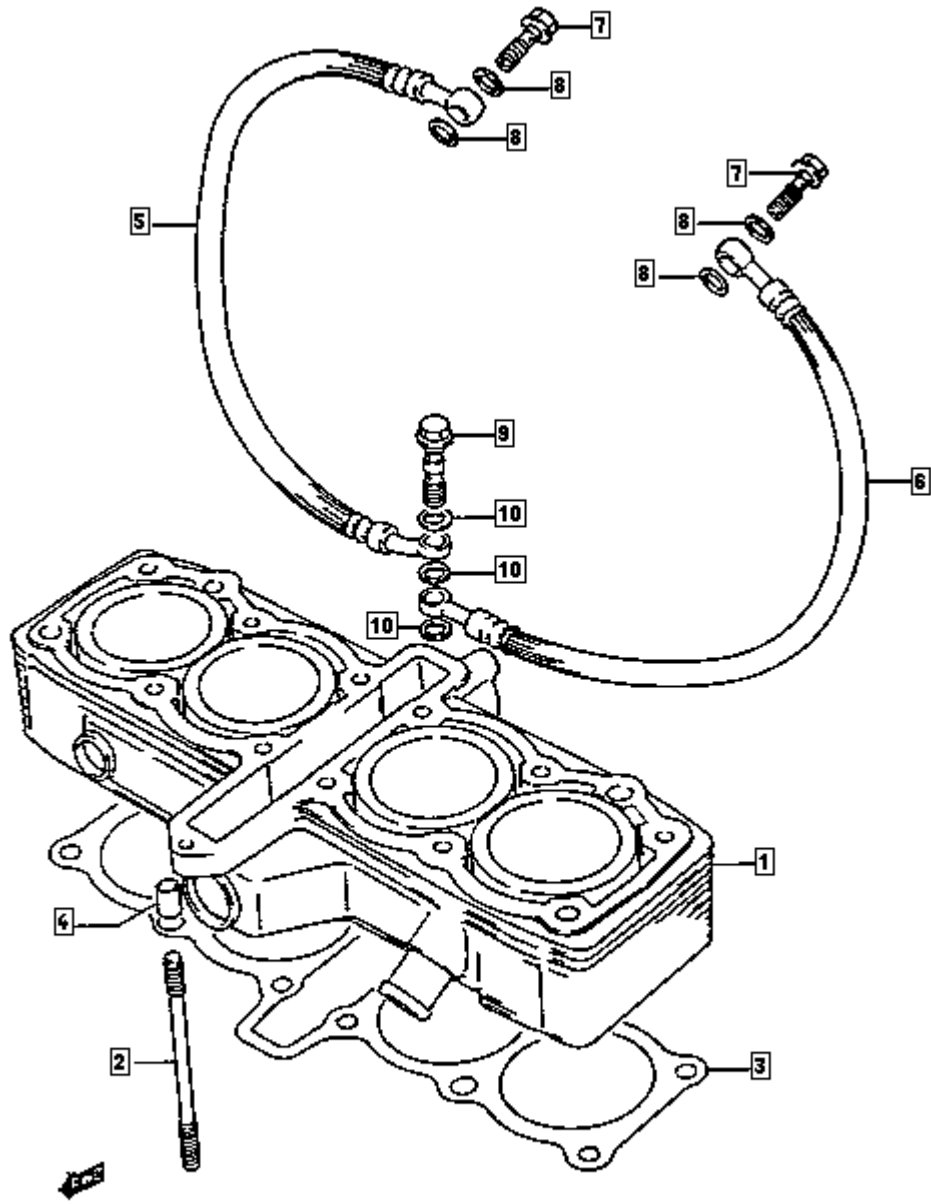
Printed in Japan

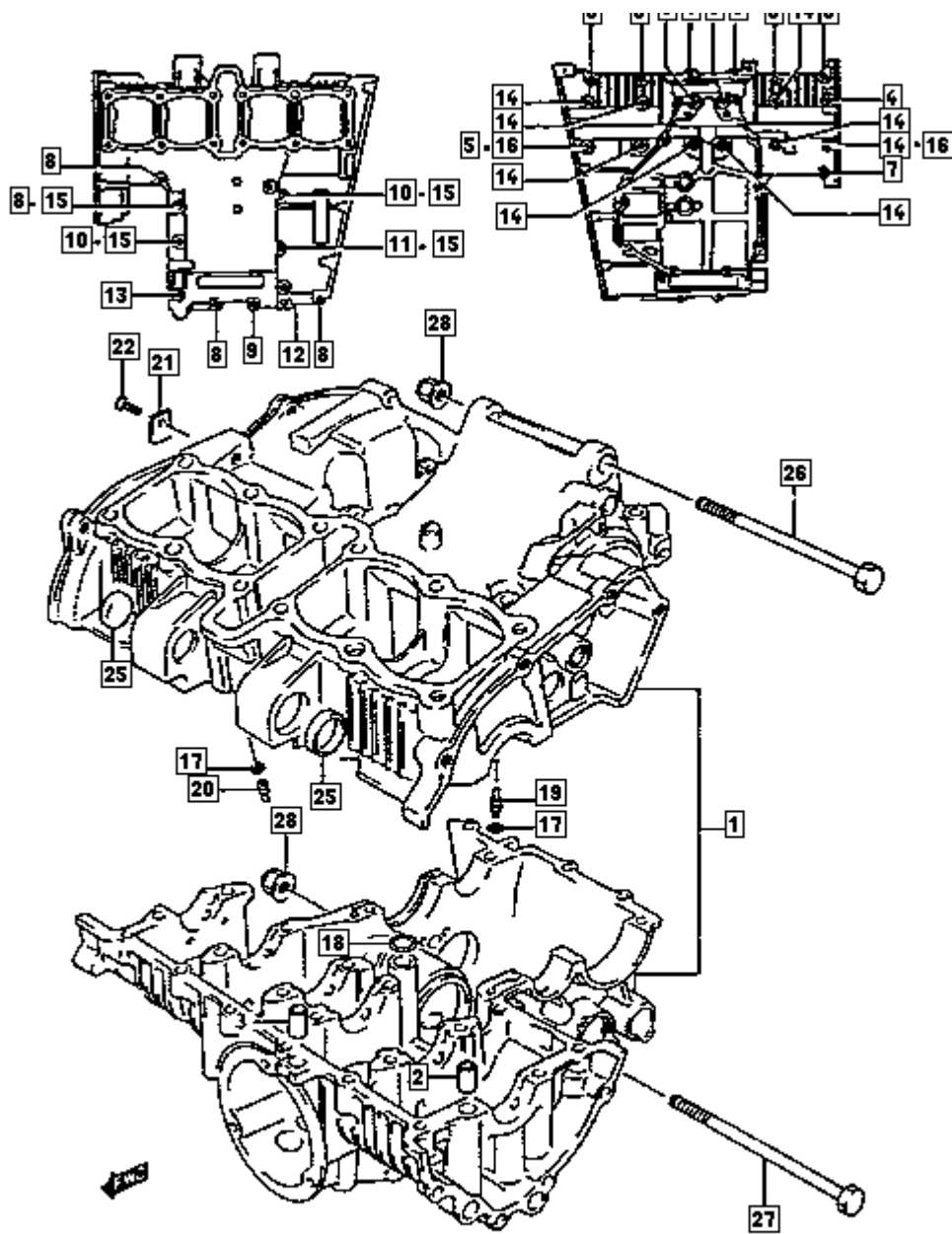
Manuale d'officina

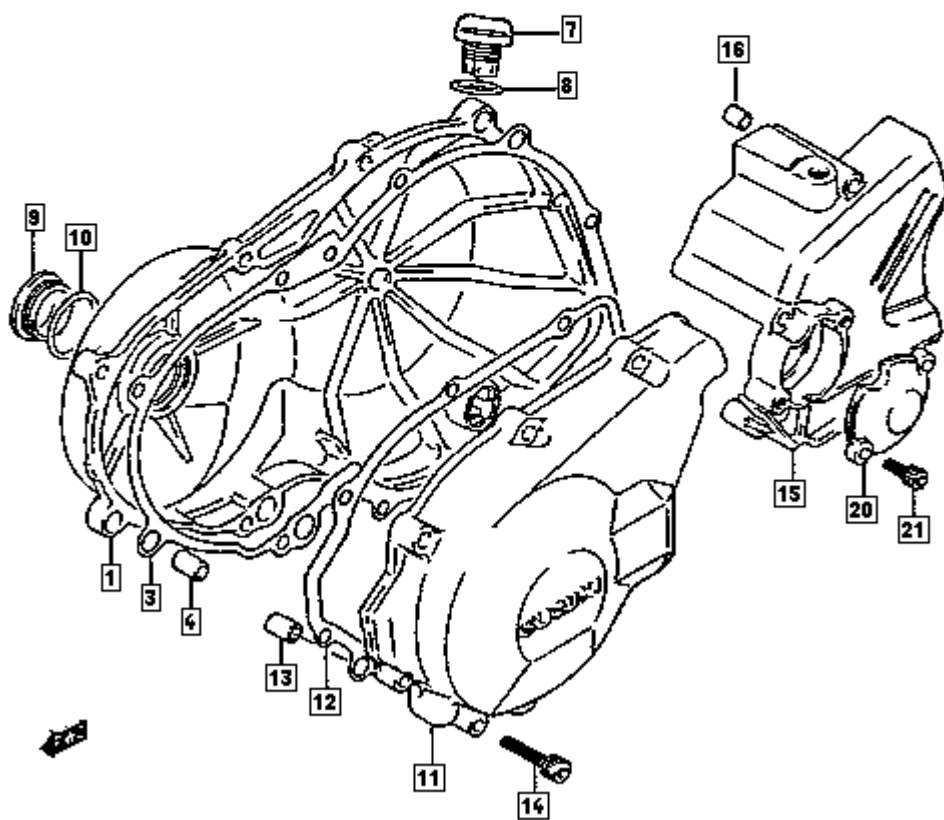
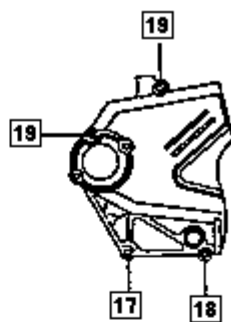
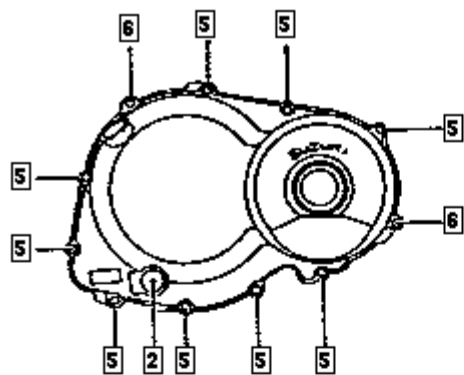
Bandit 400

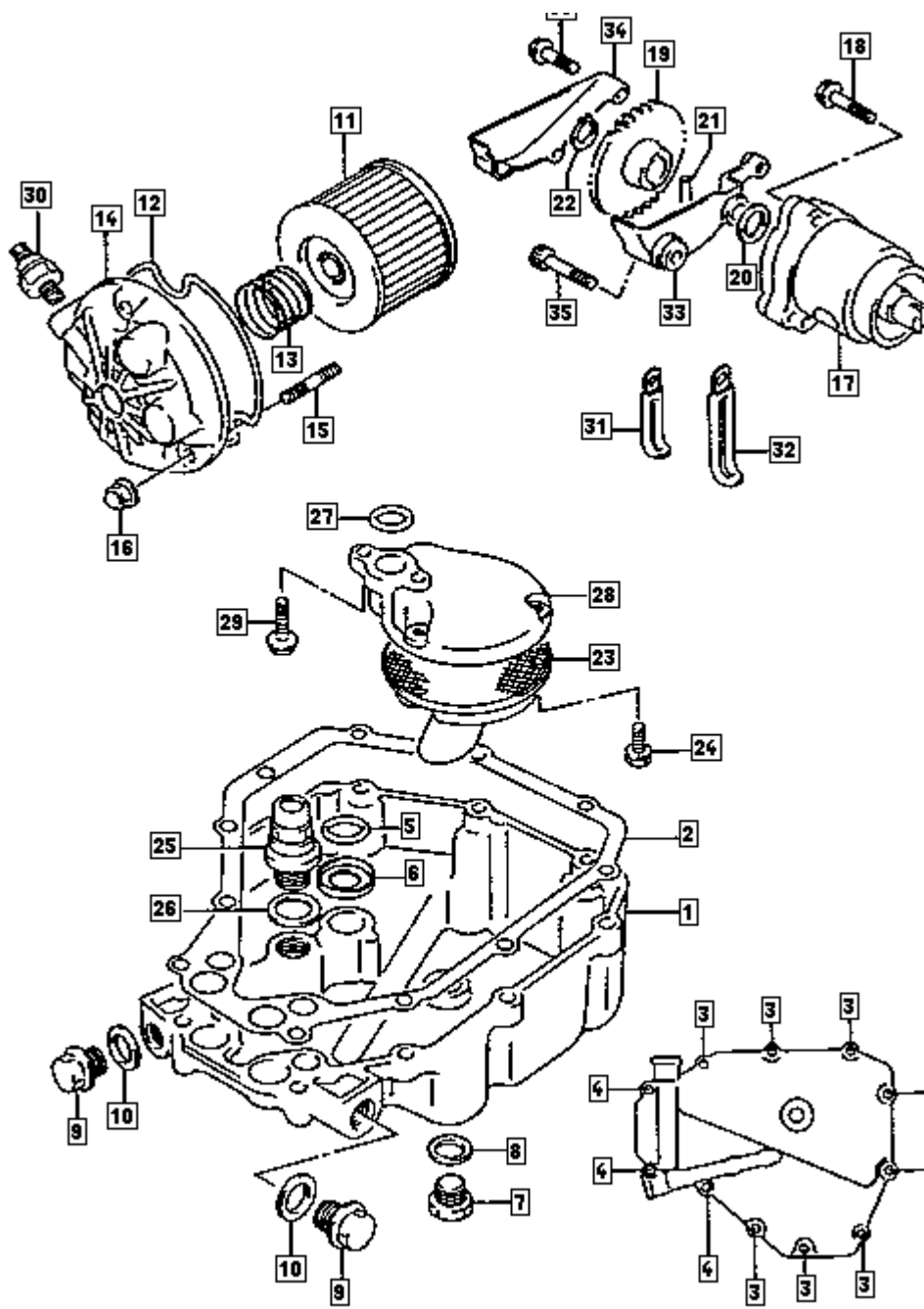


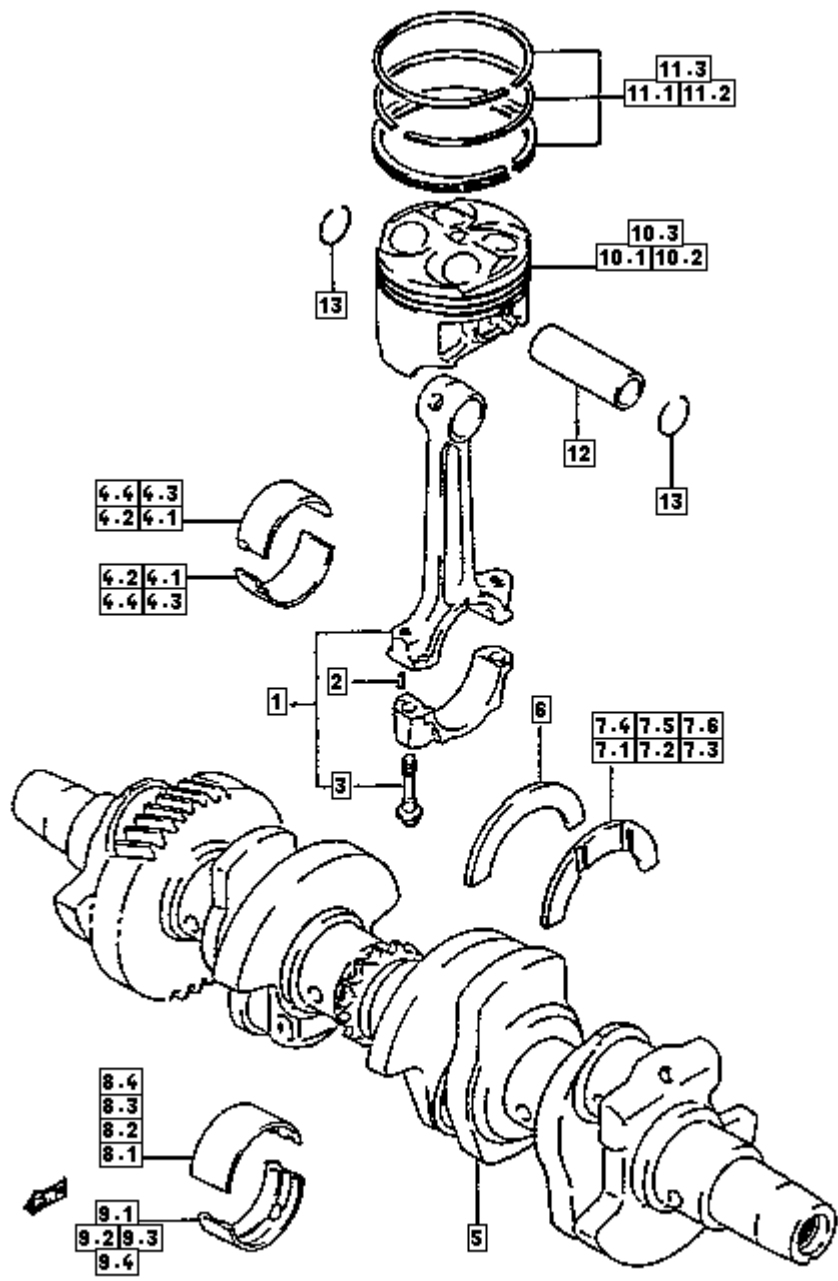


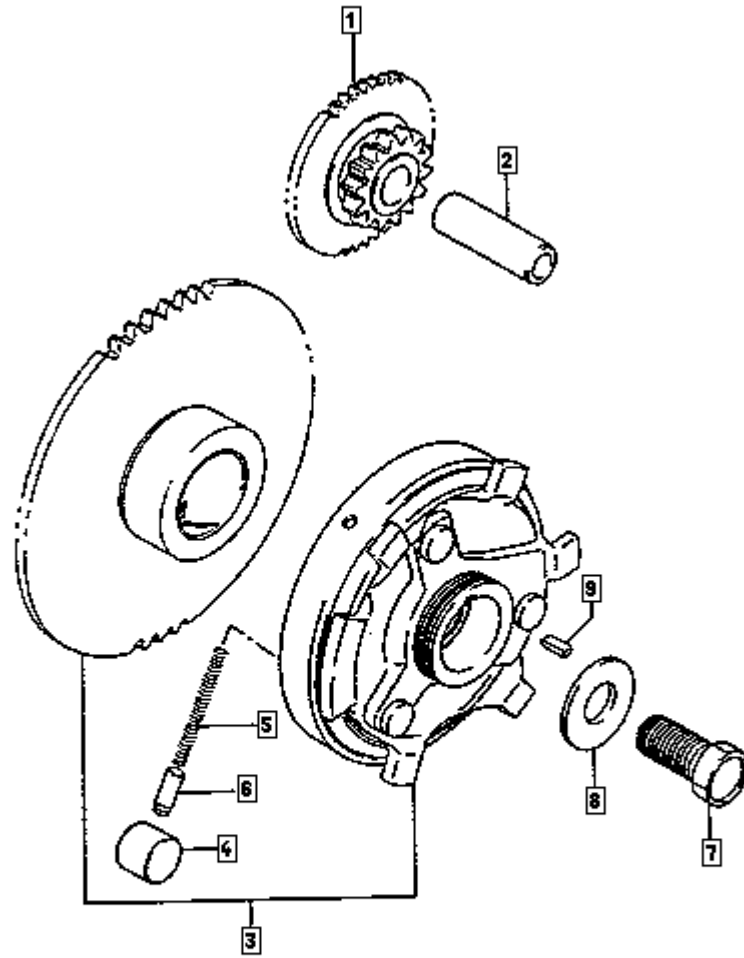




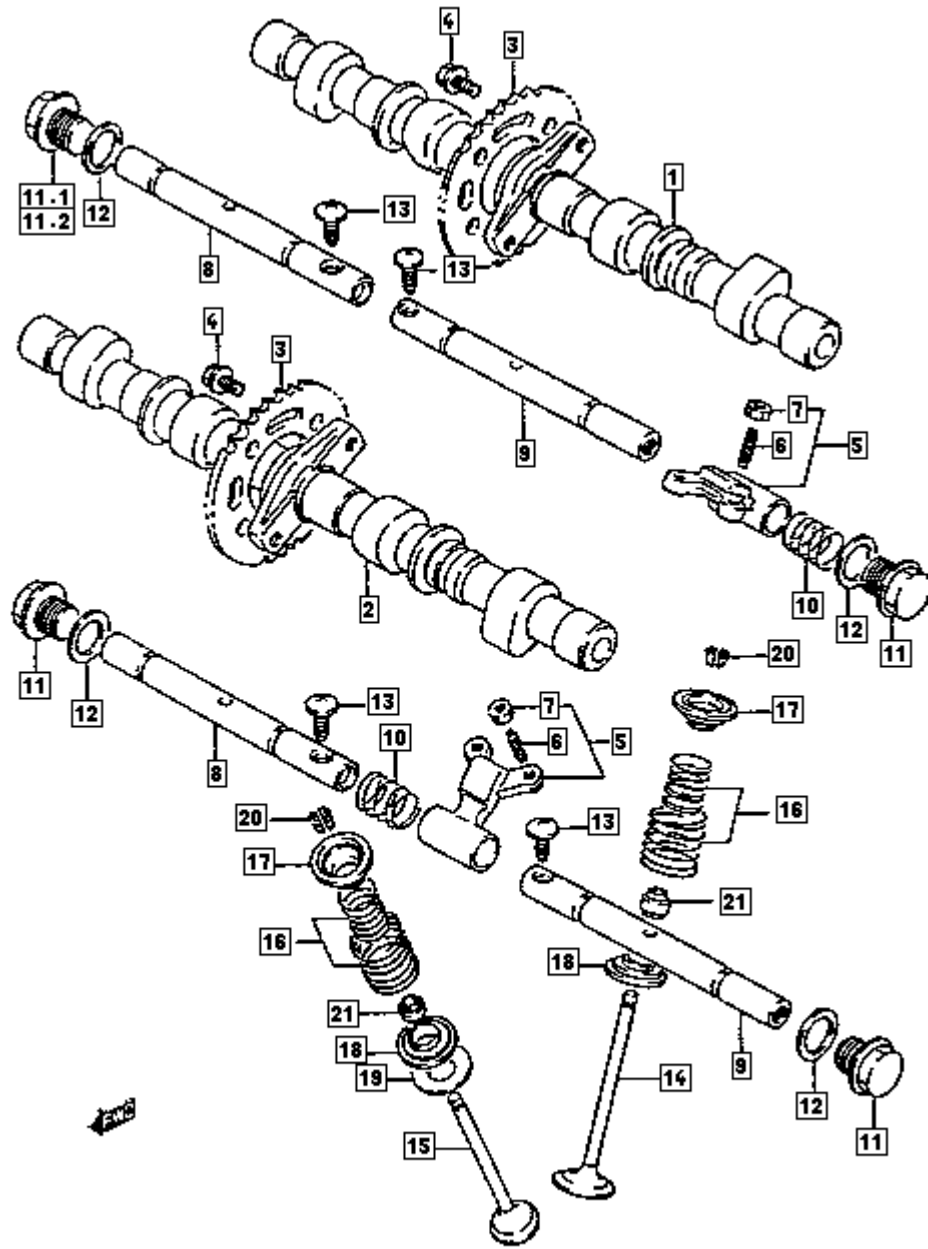








←



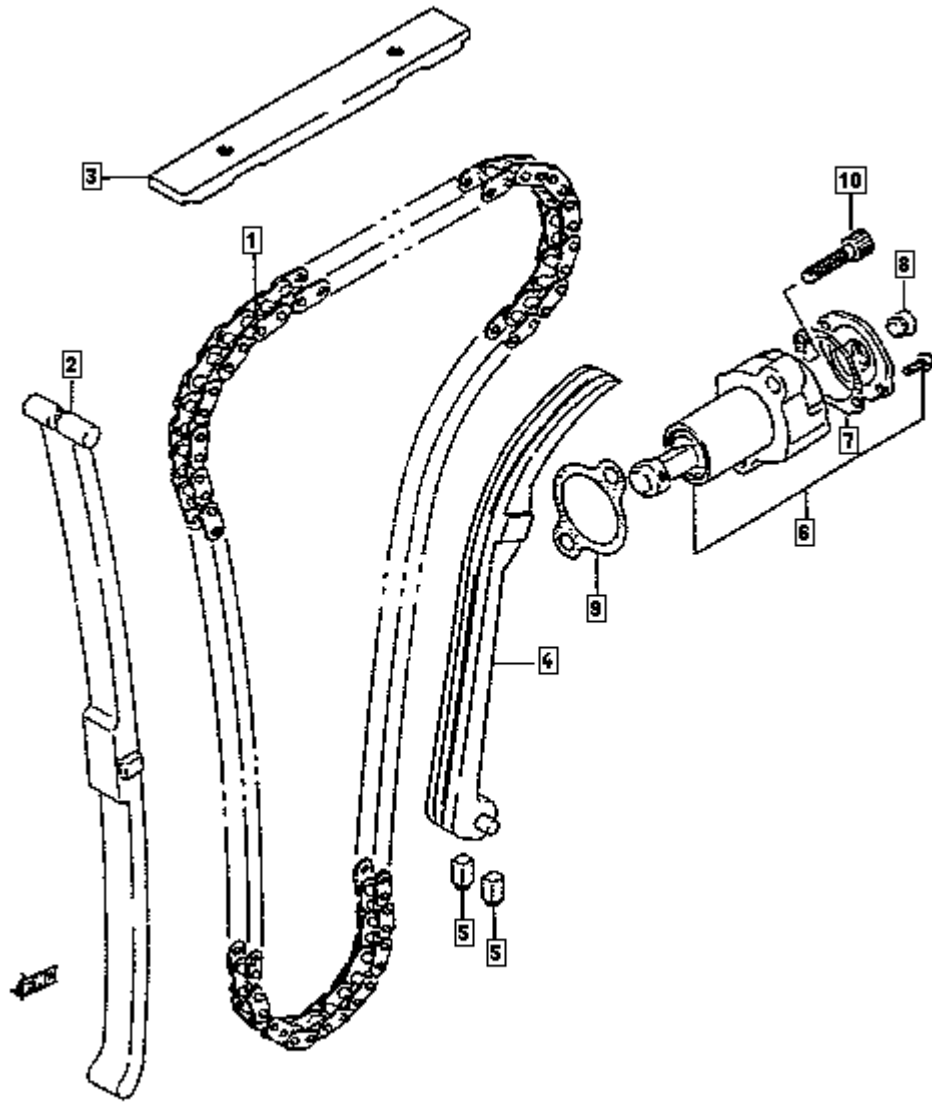
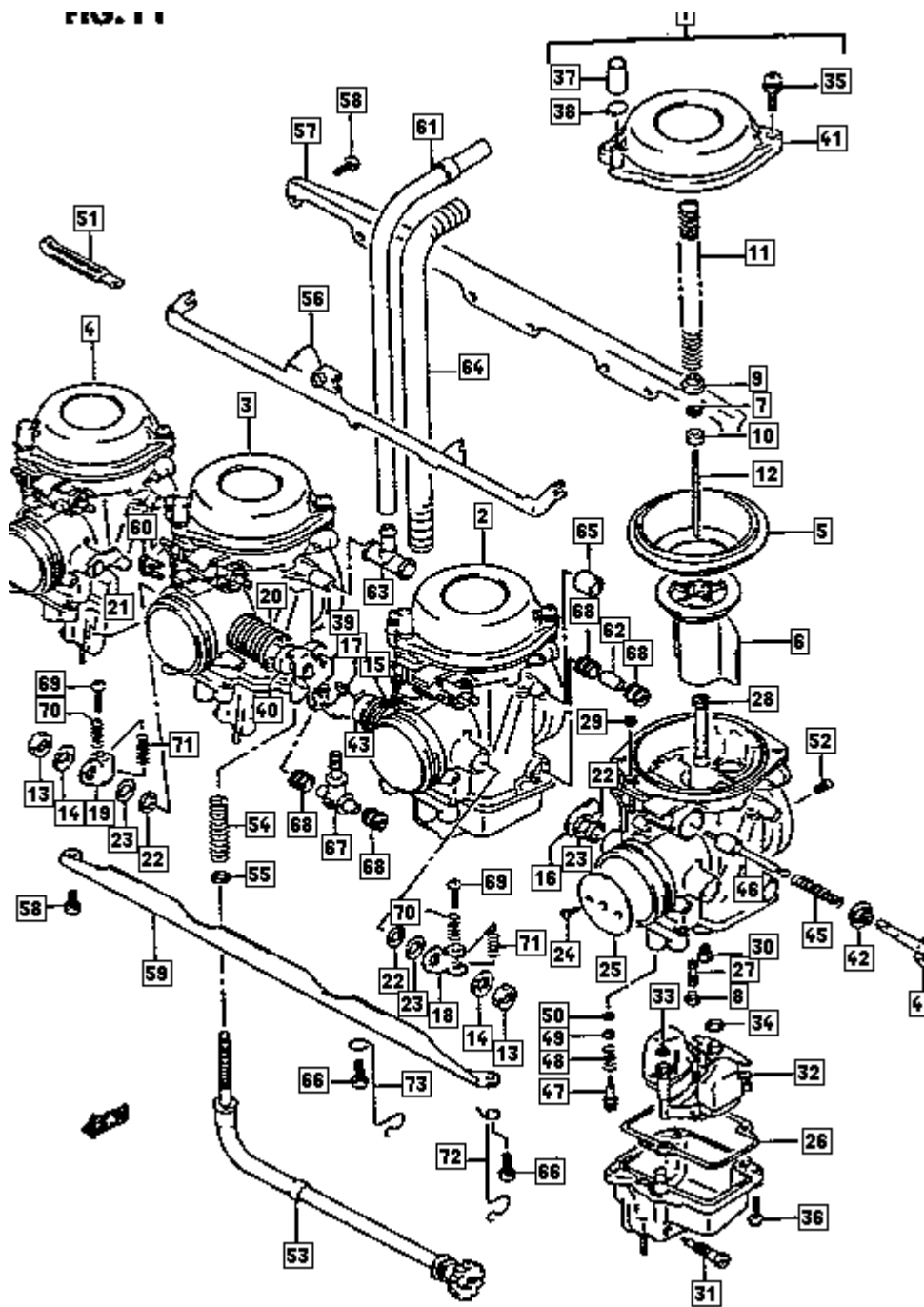
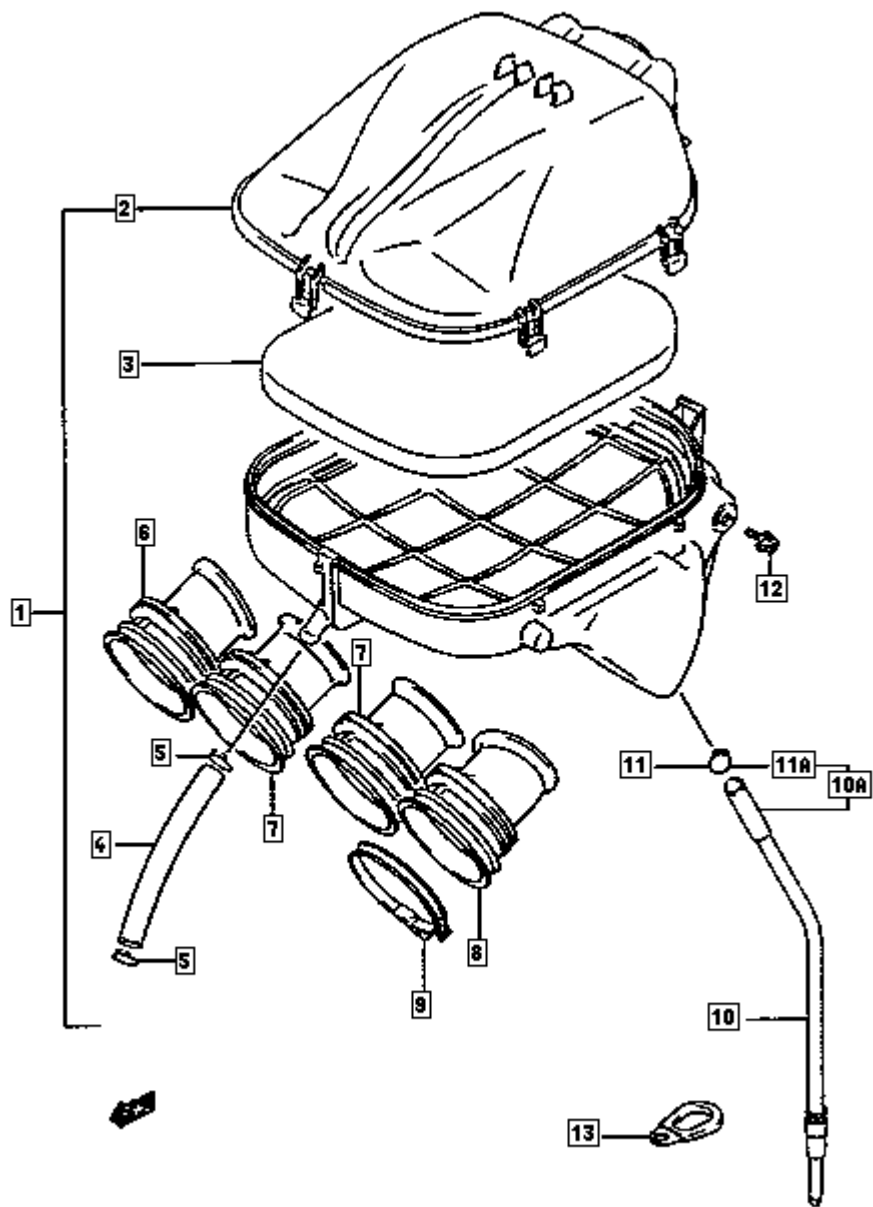
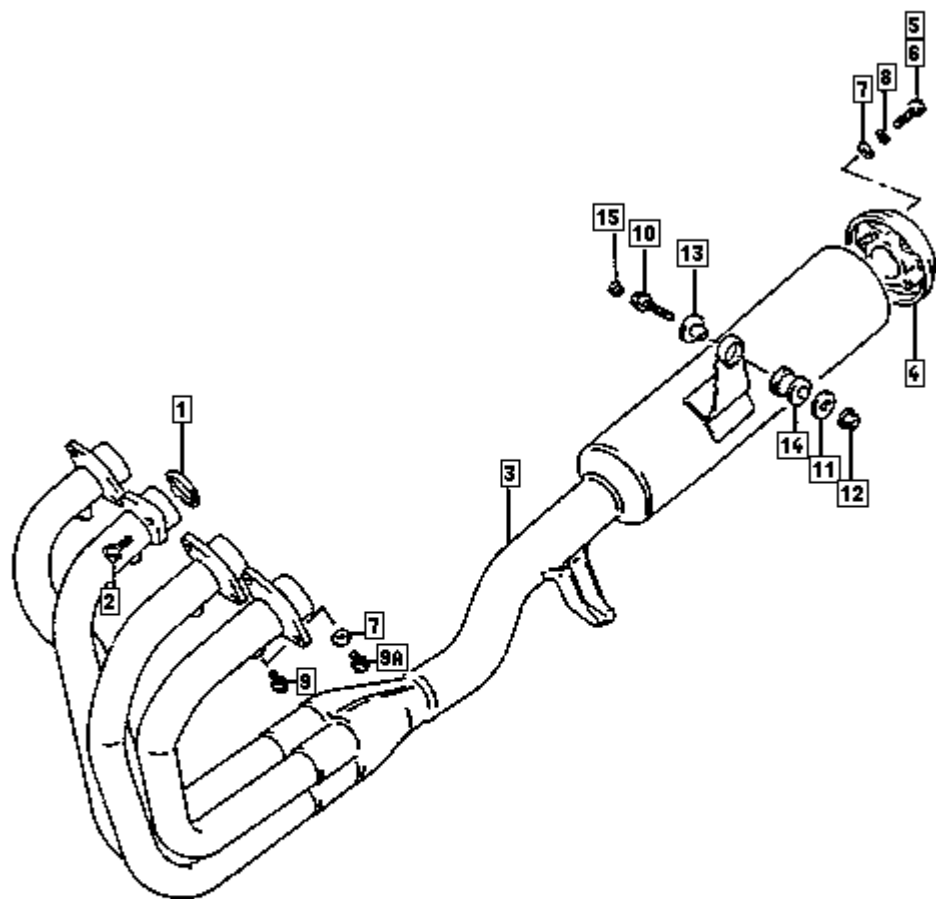
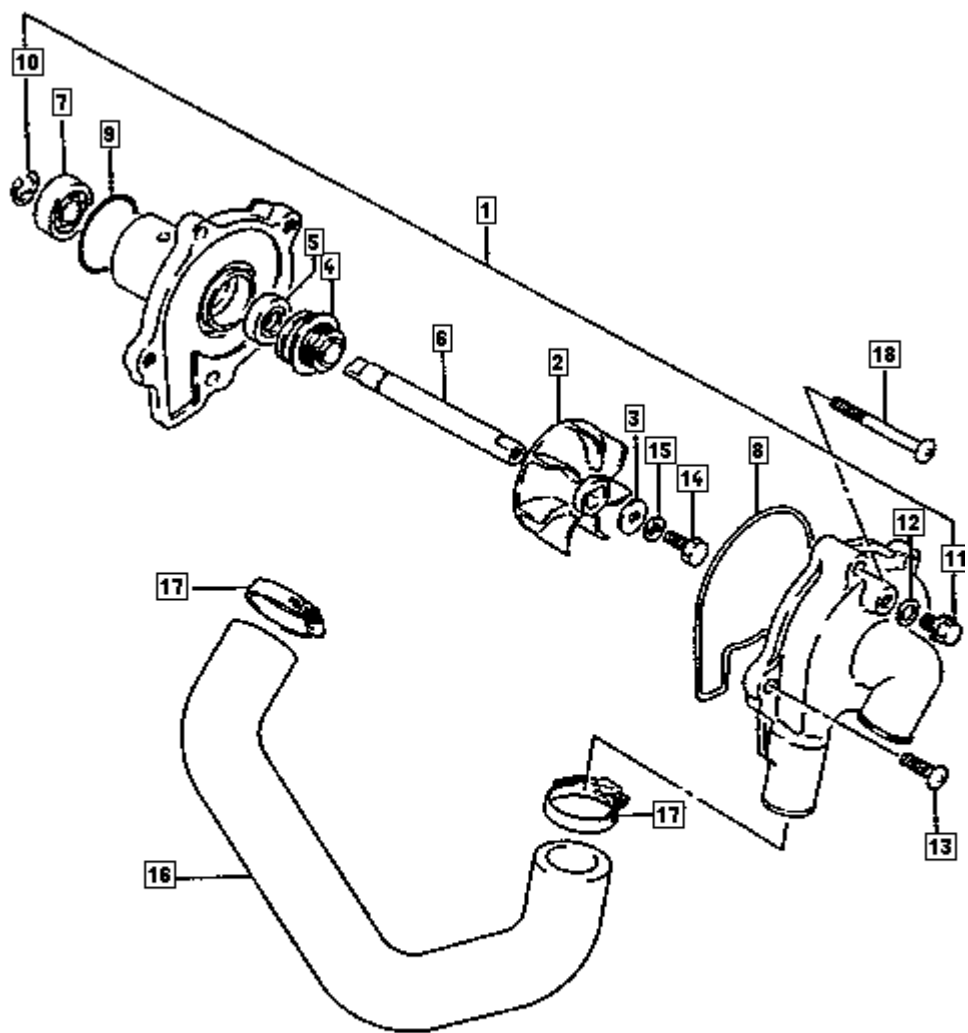


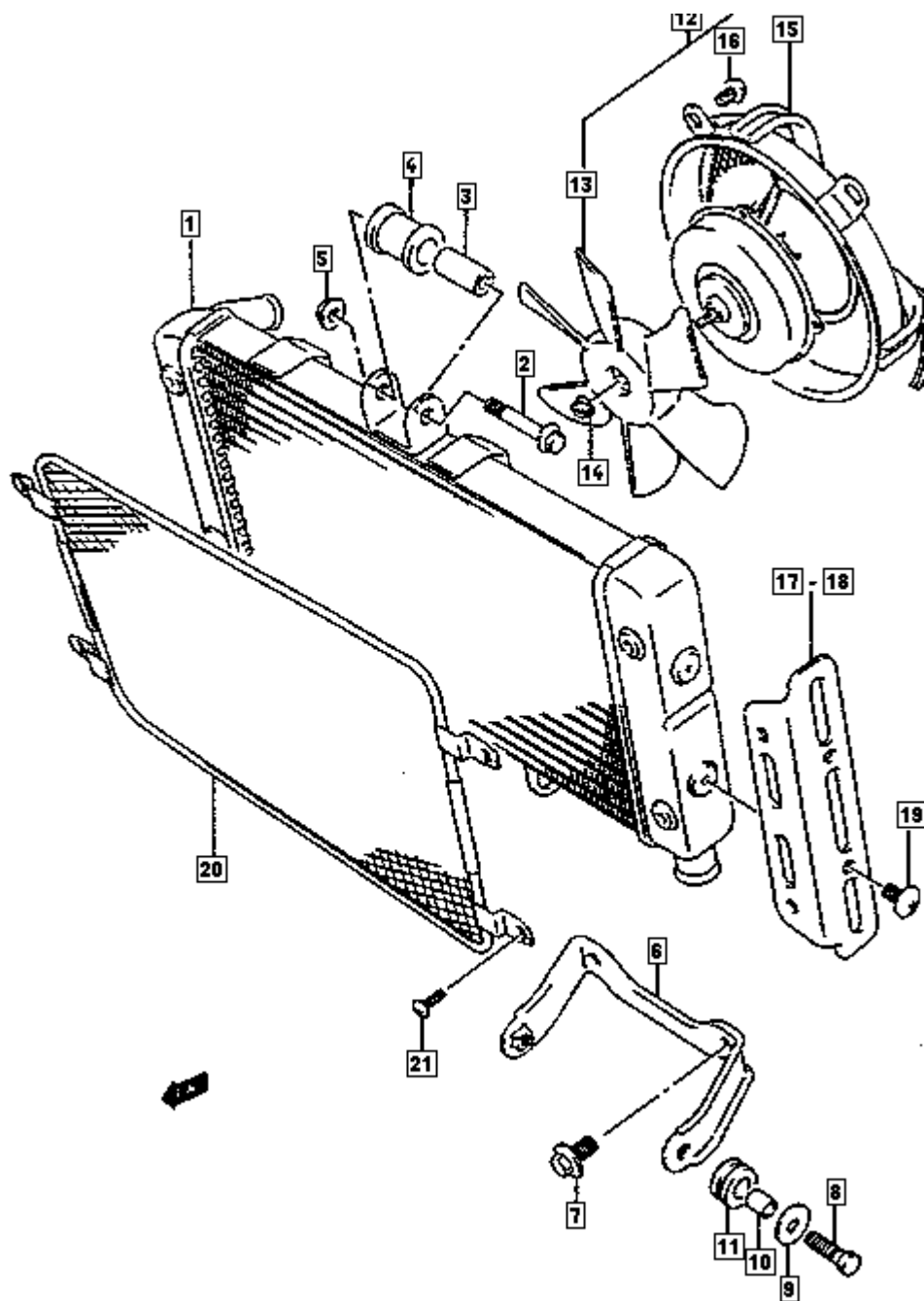
FIG. 11











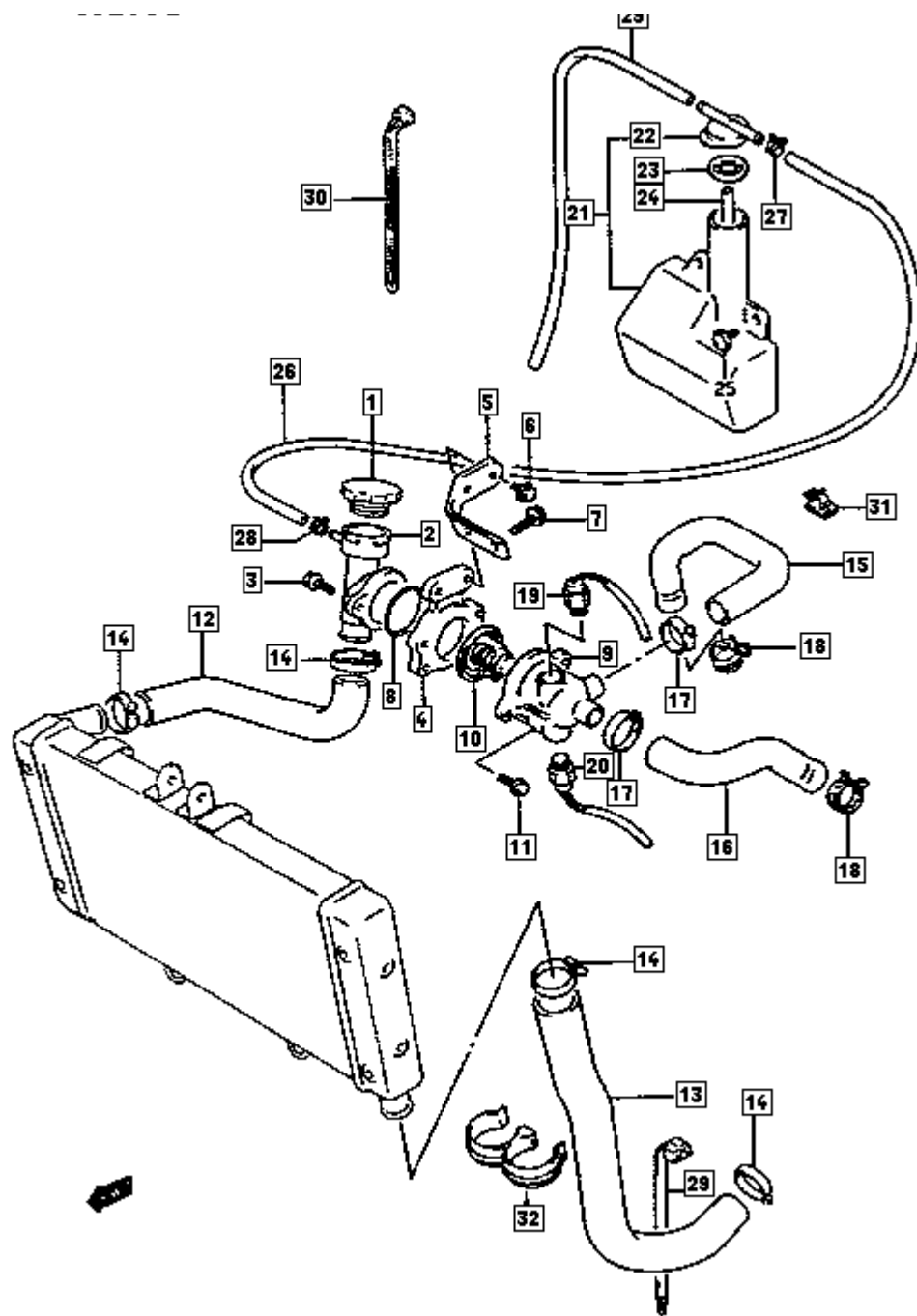
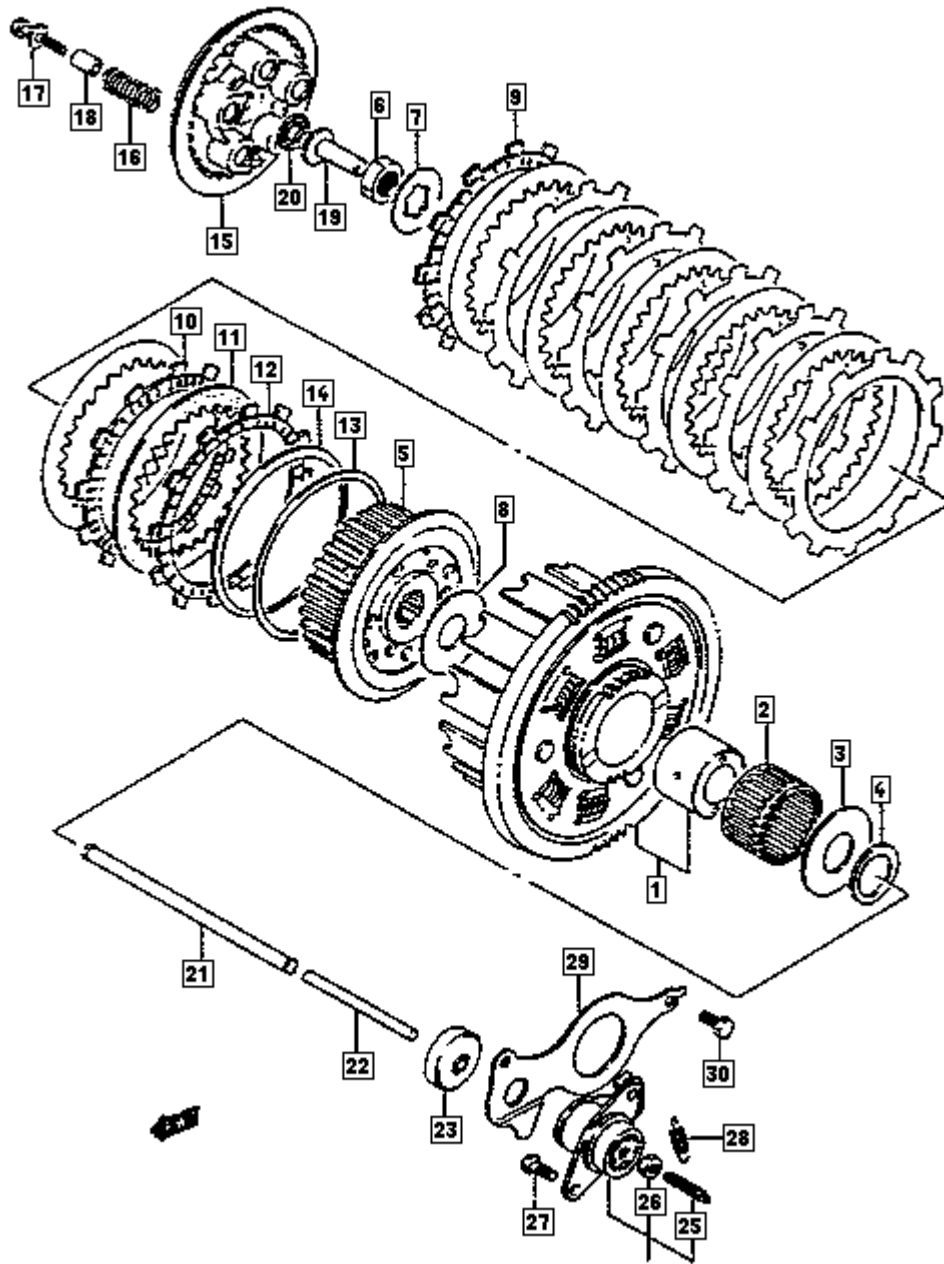
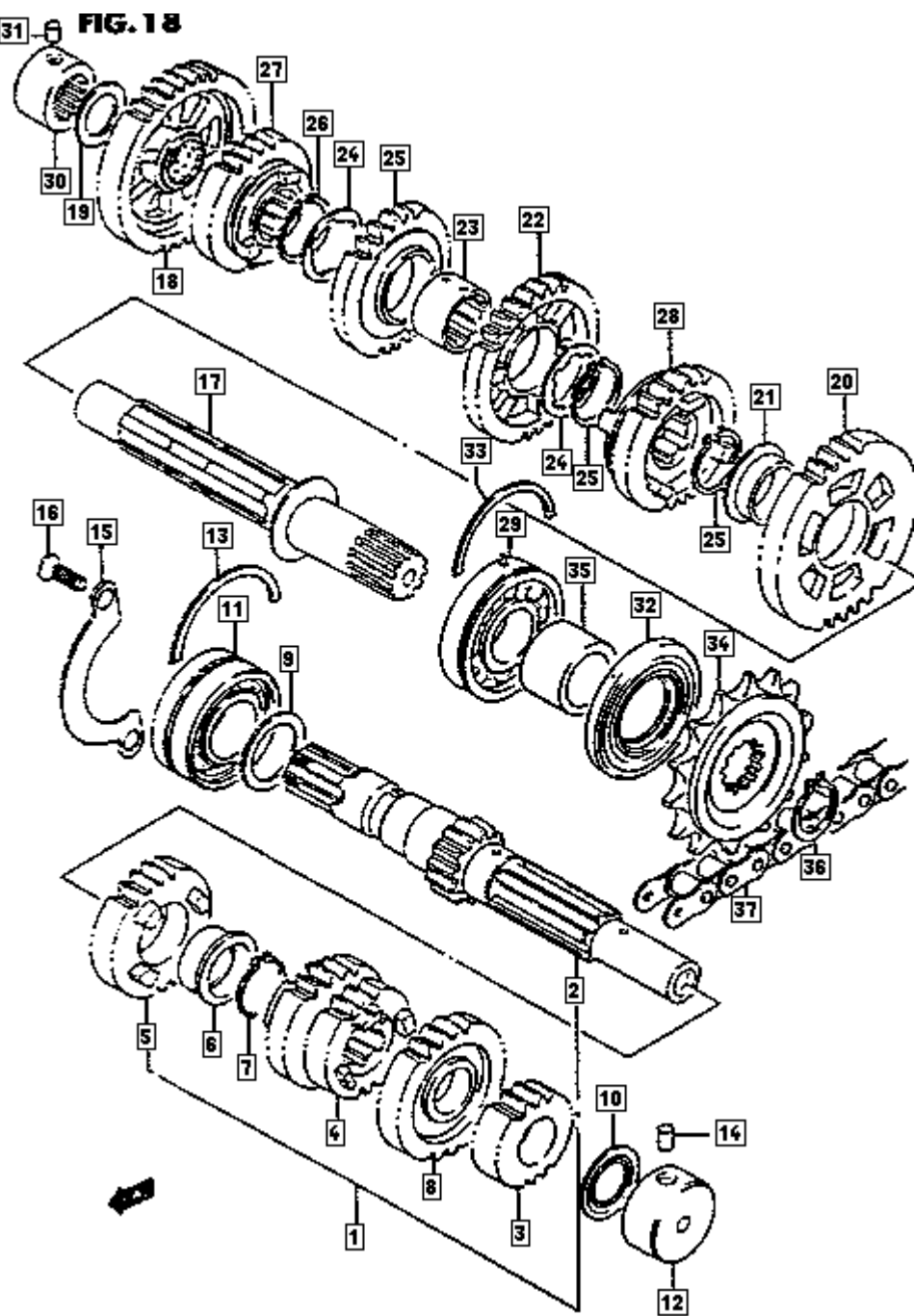


FIG. 17



31 **FIG. 18**



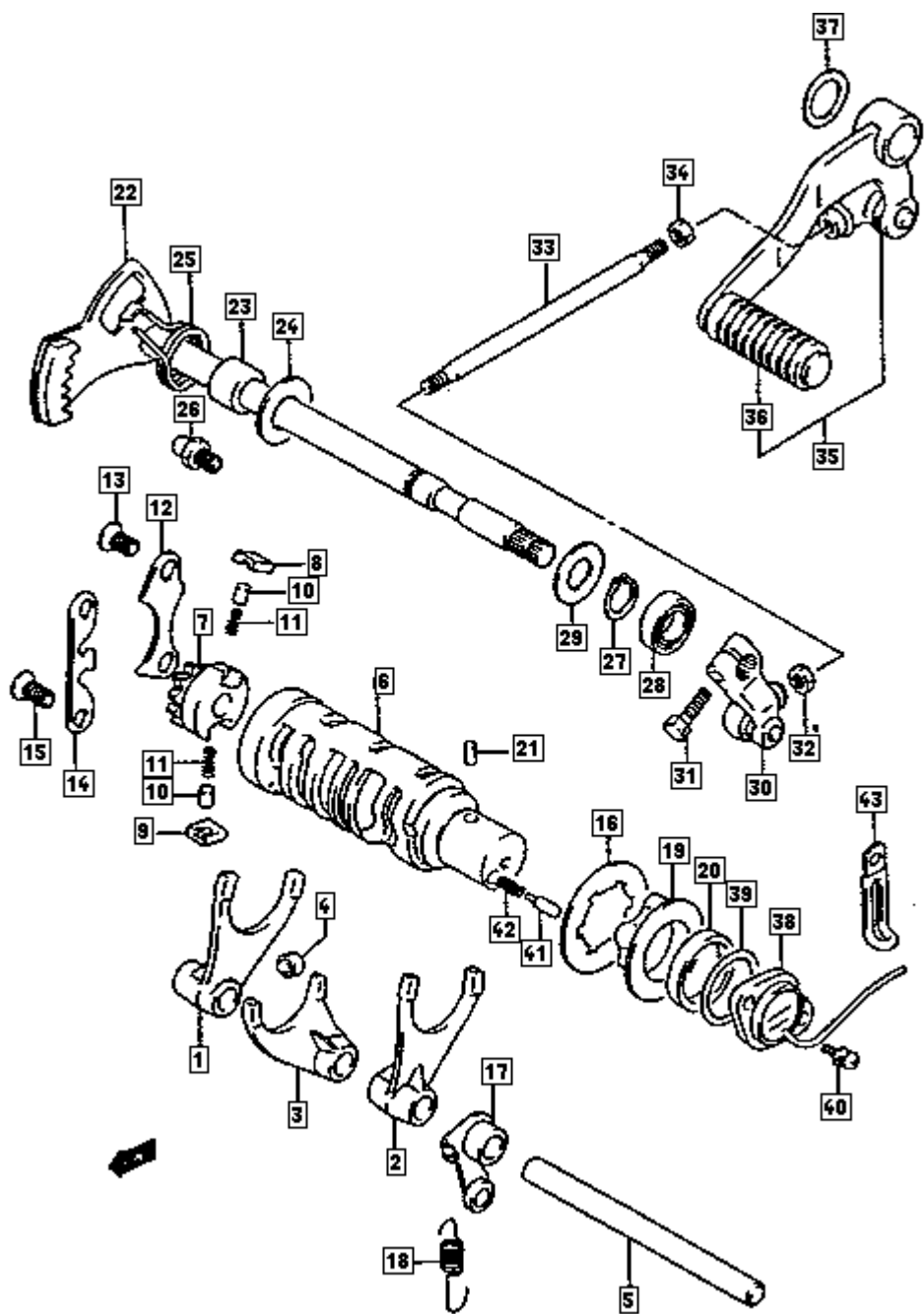
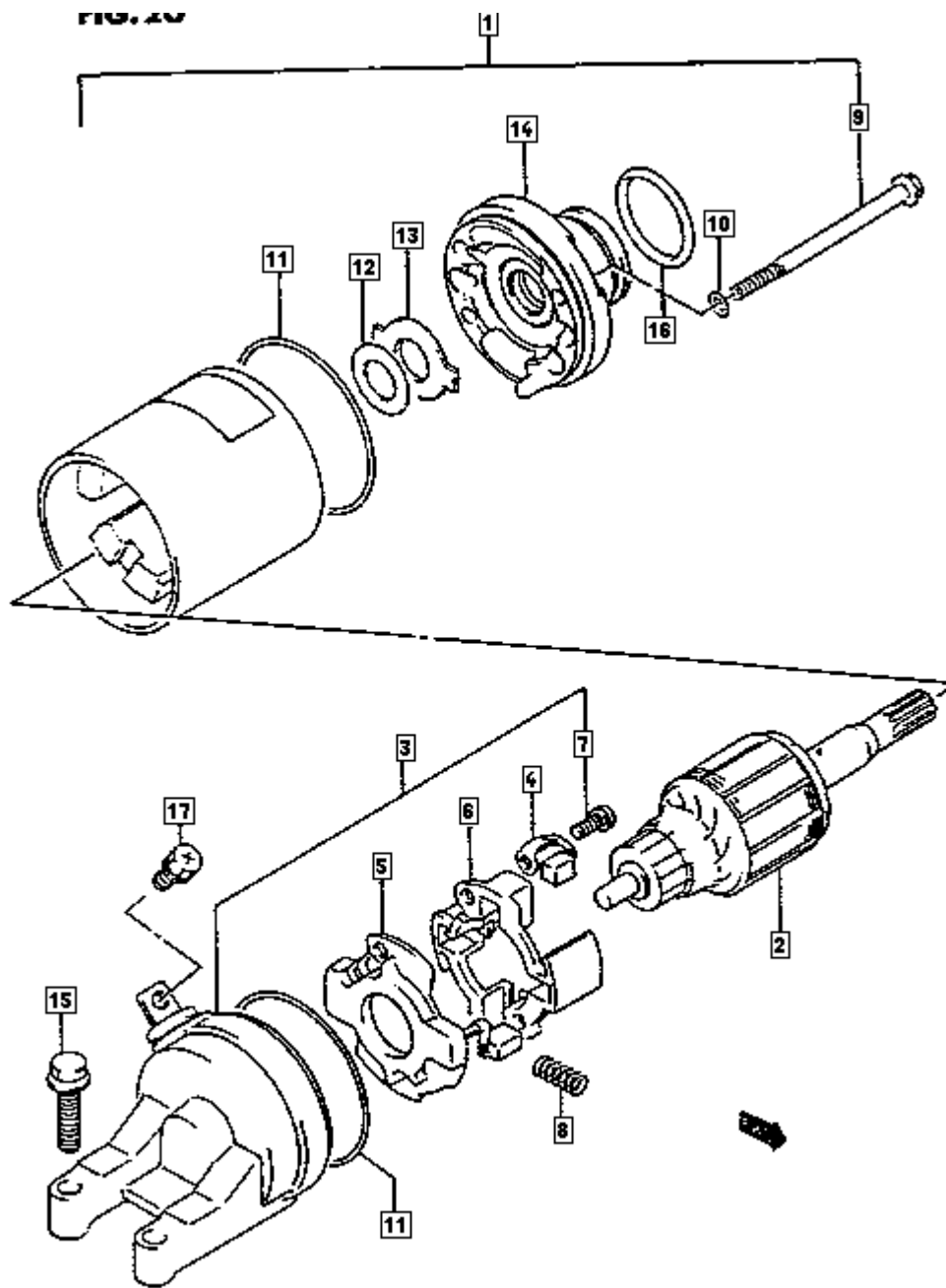
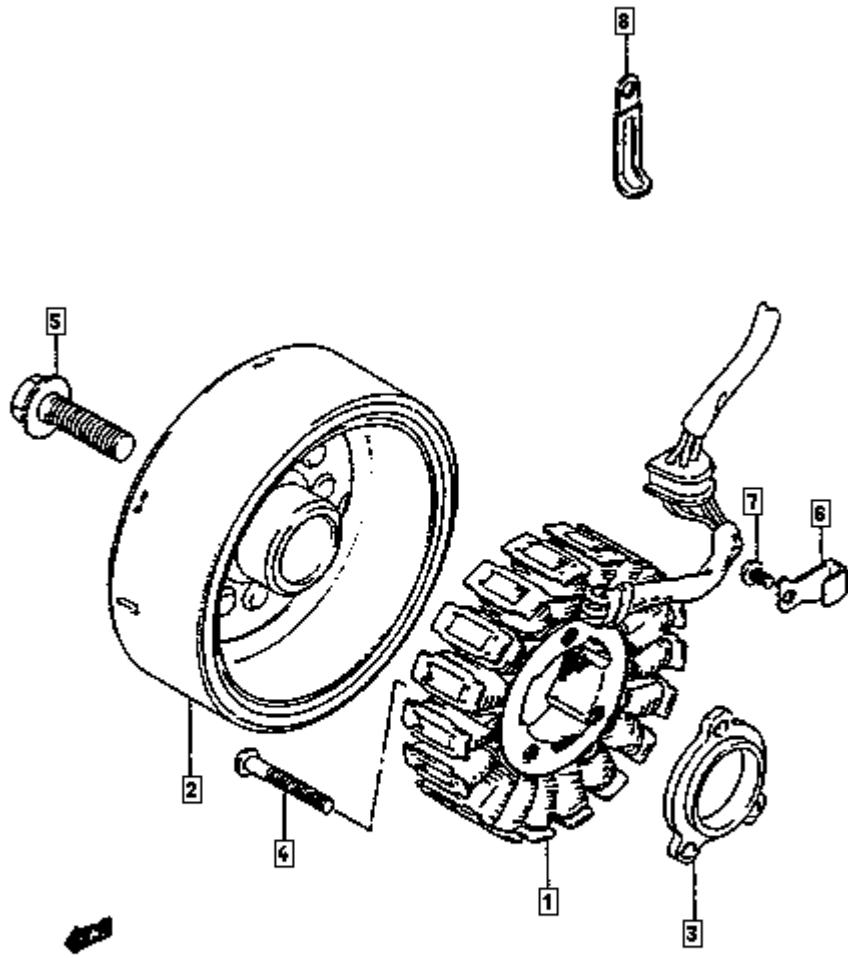
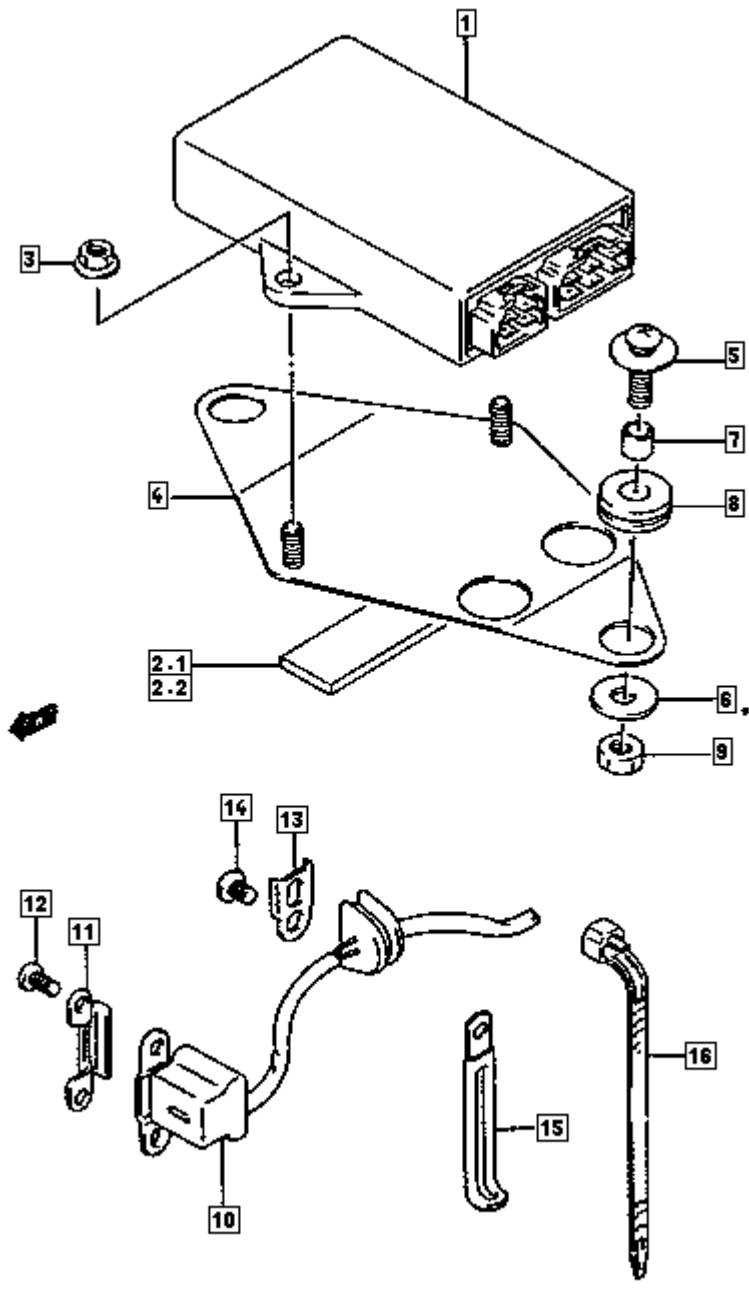
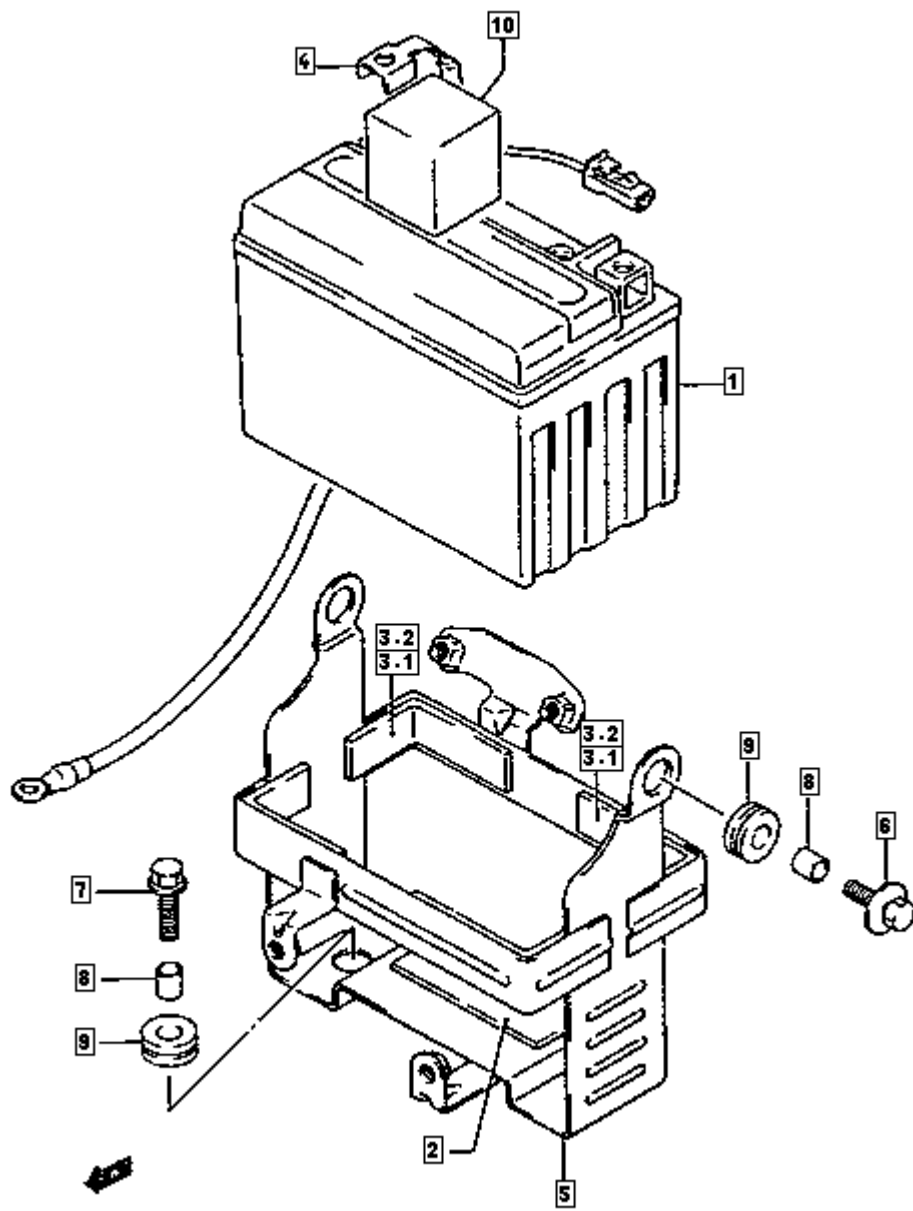


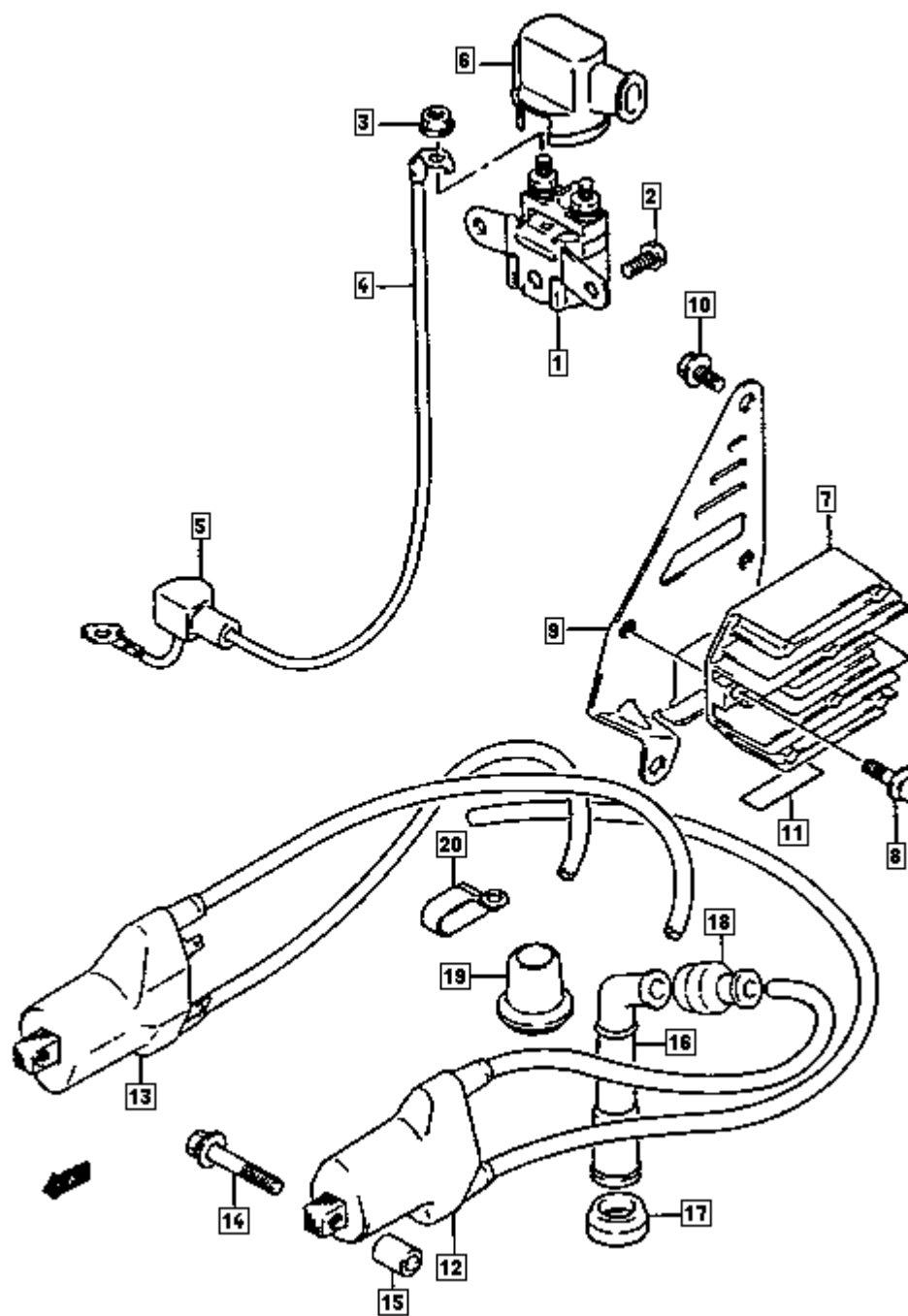
FIG. 20

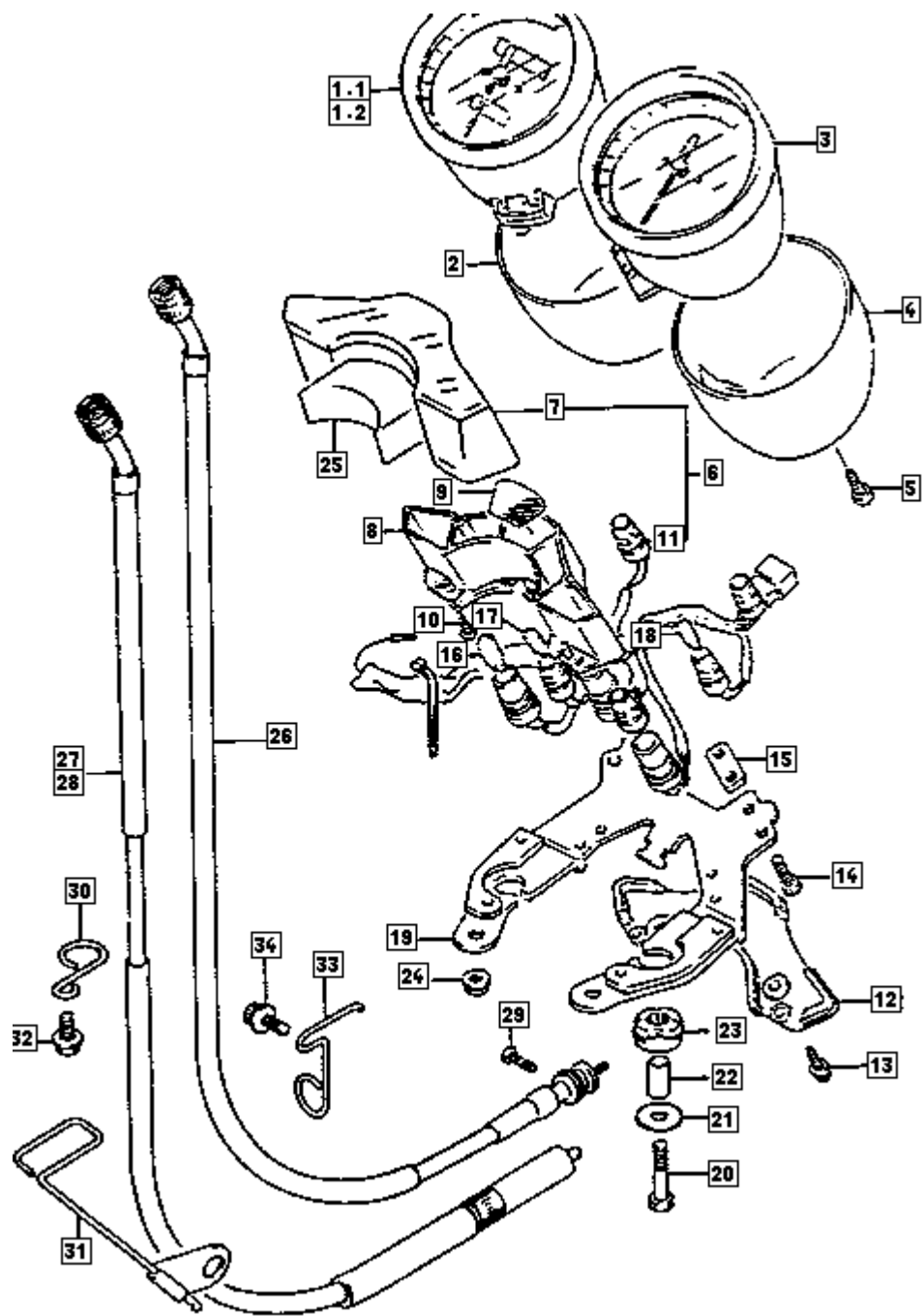


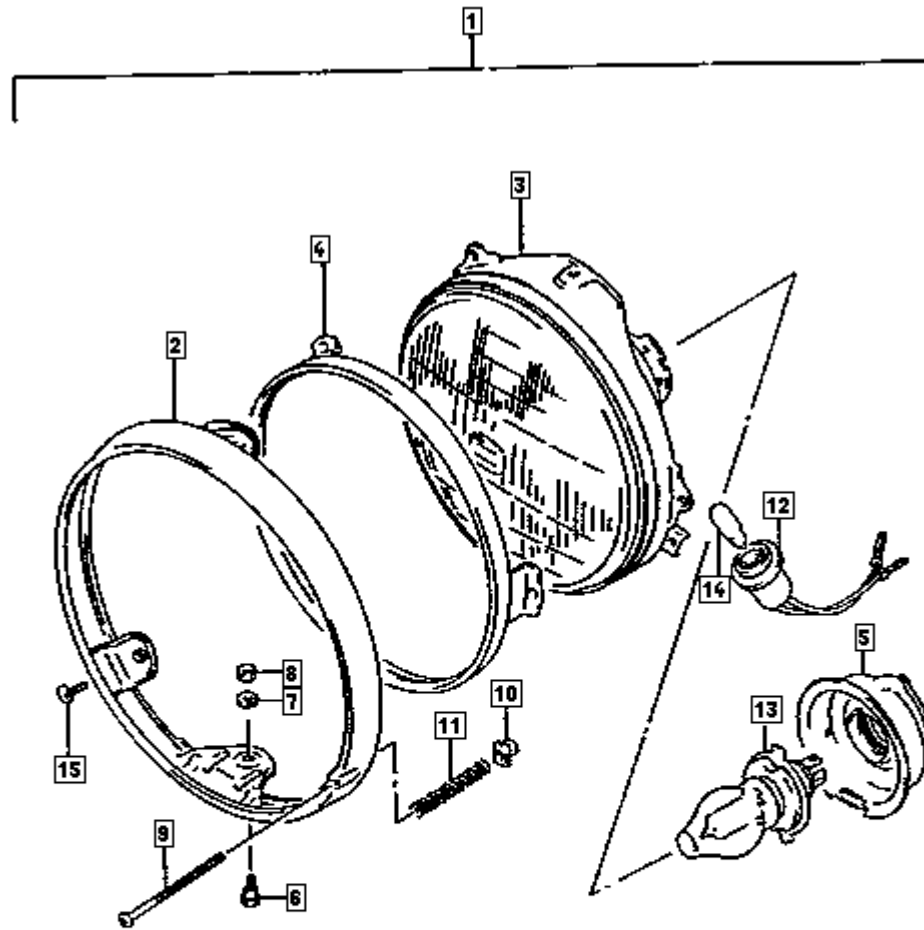


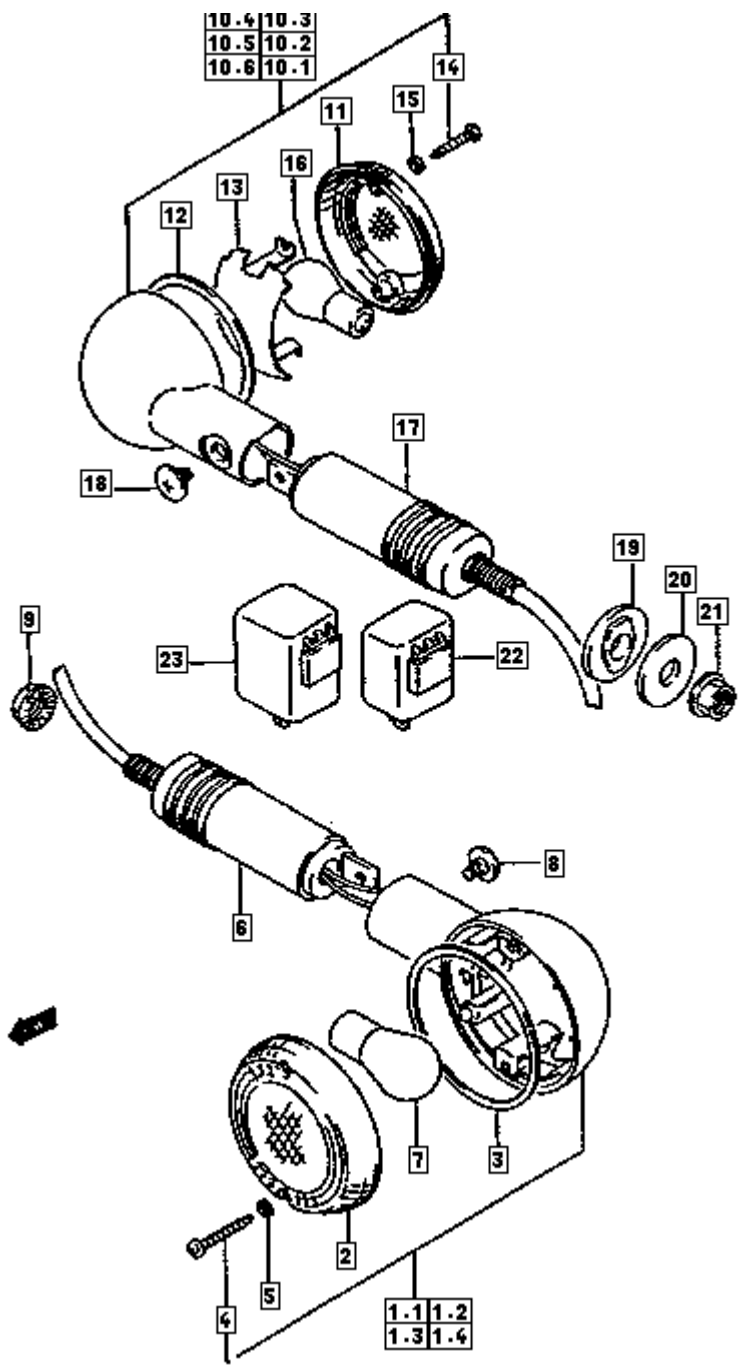












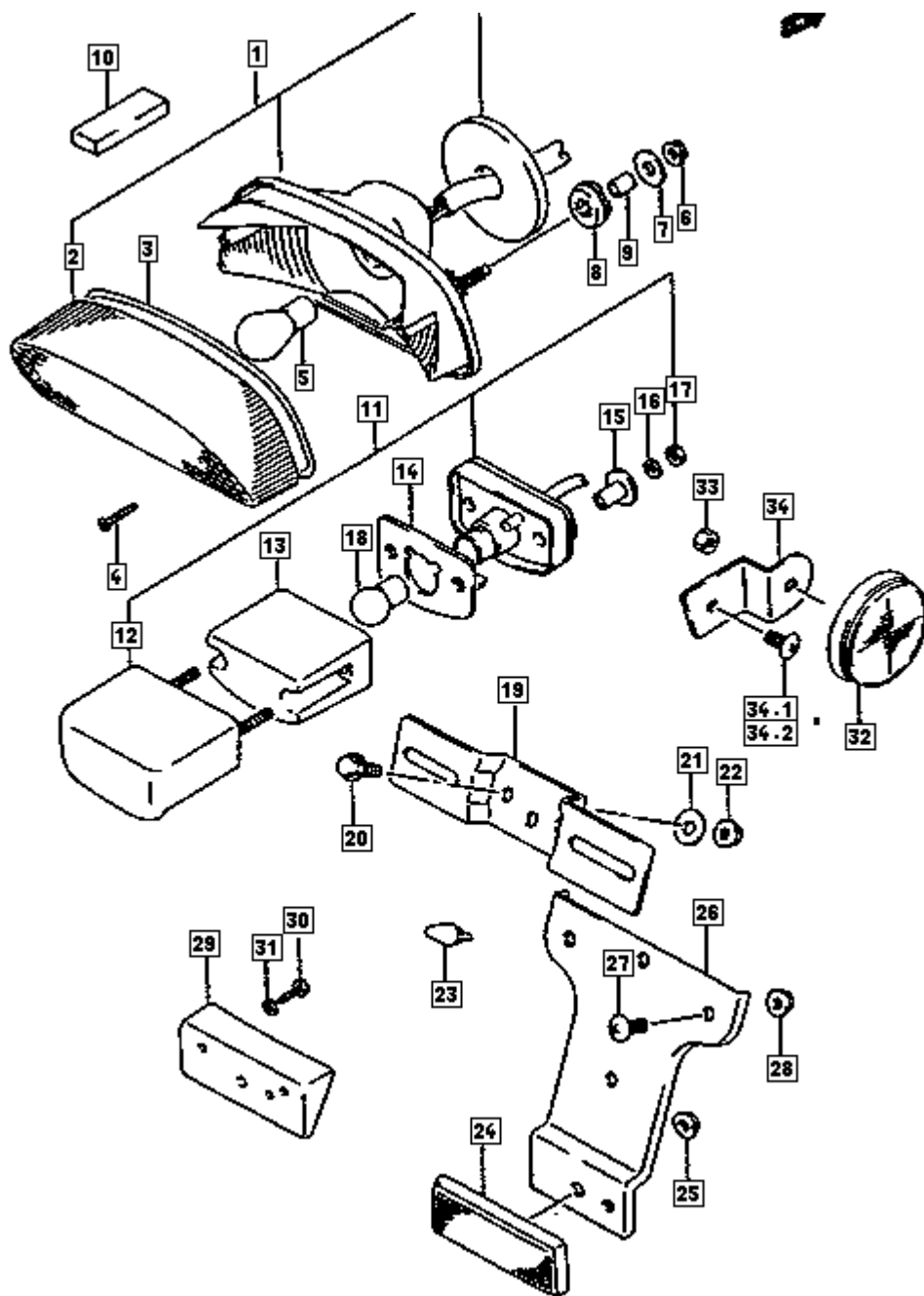


FIG. 30

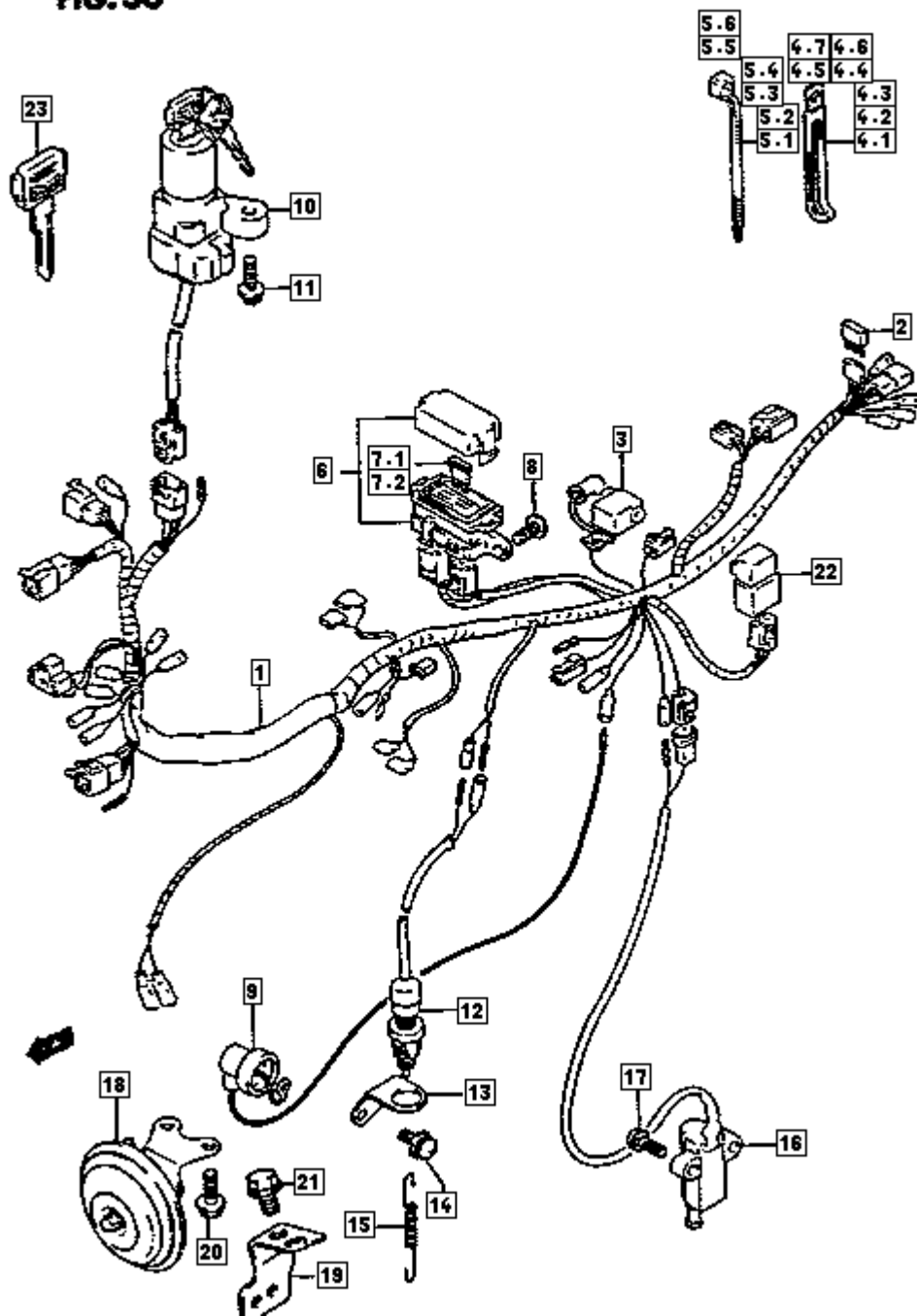


FIG. 31

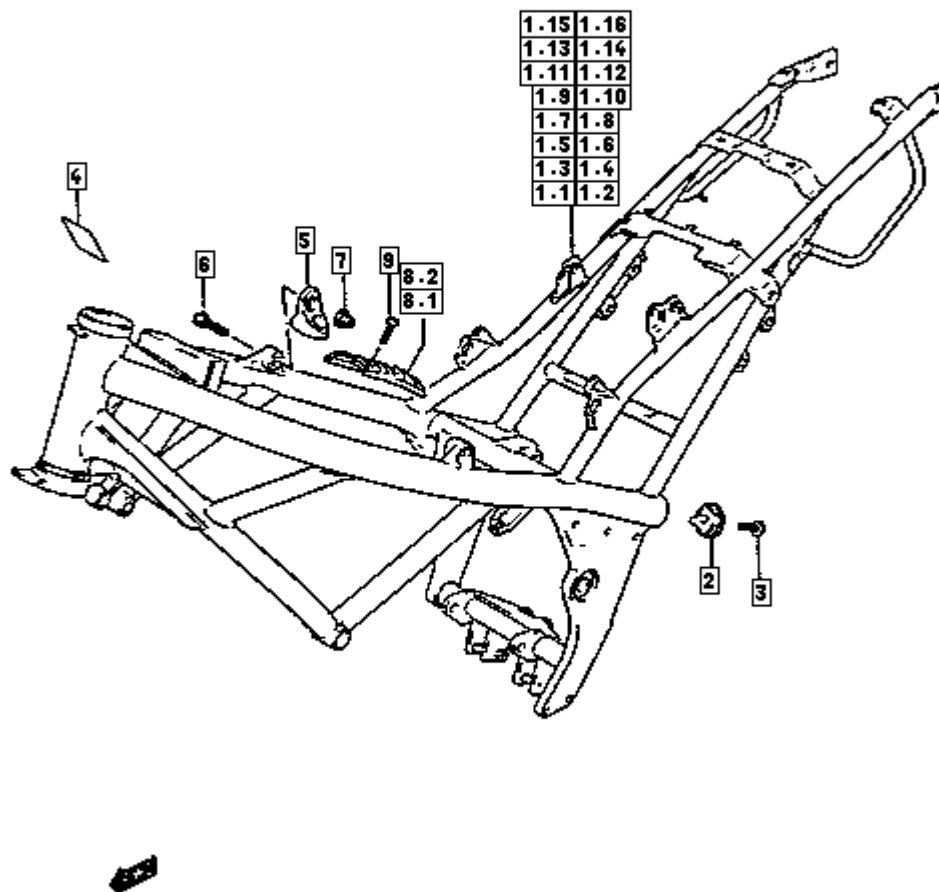


FIG. 24

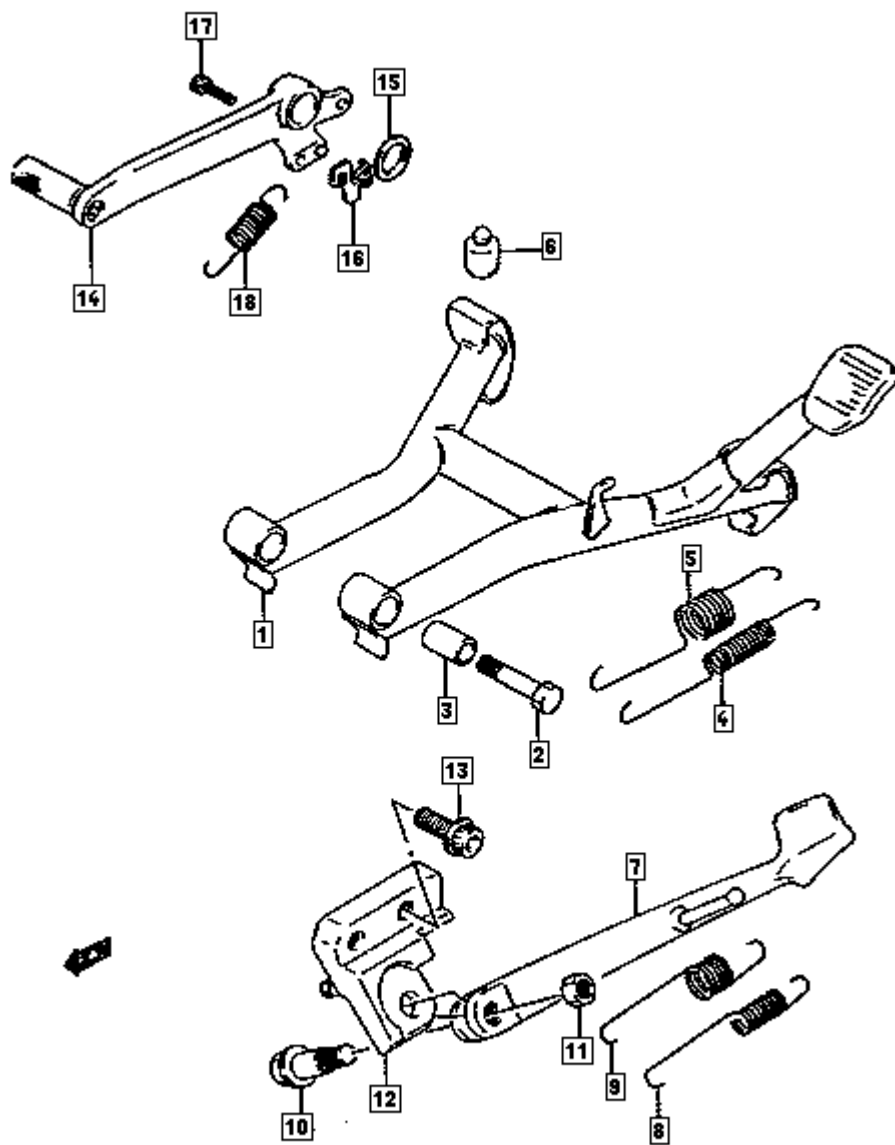
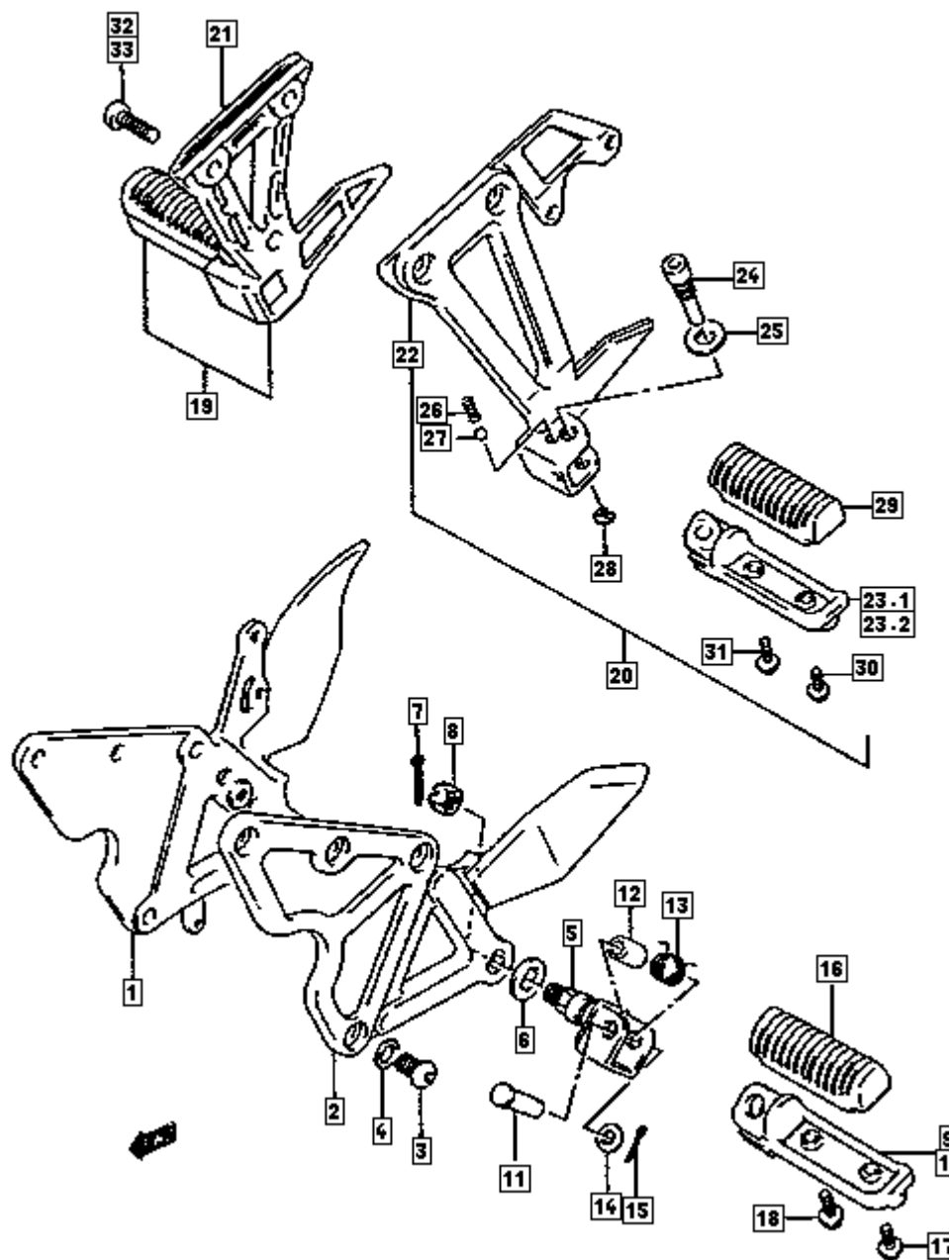


FIG. 33



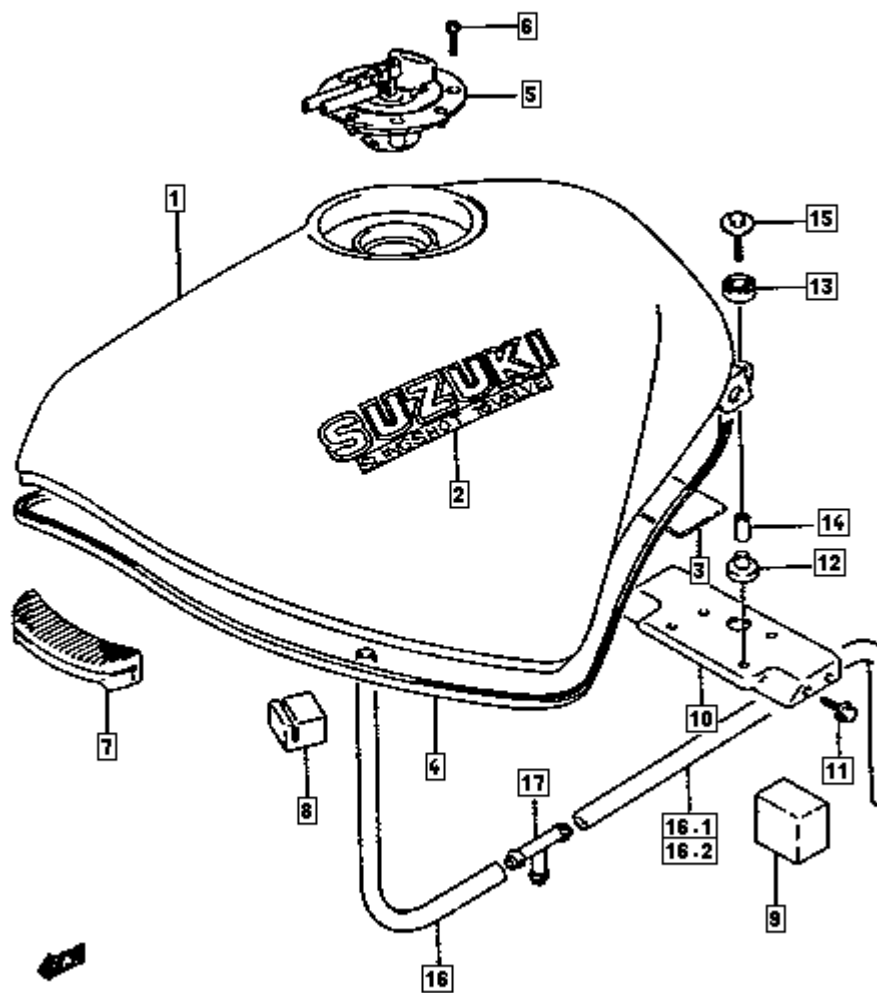
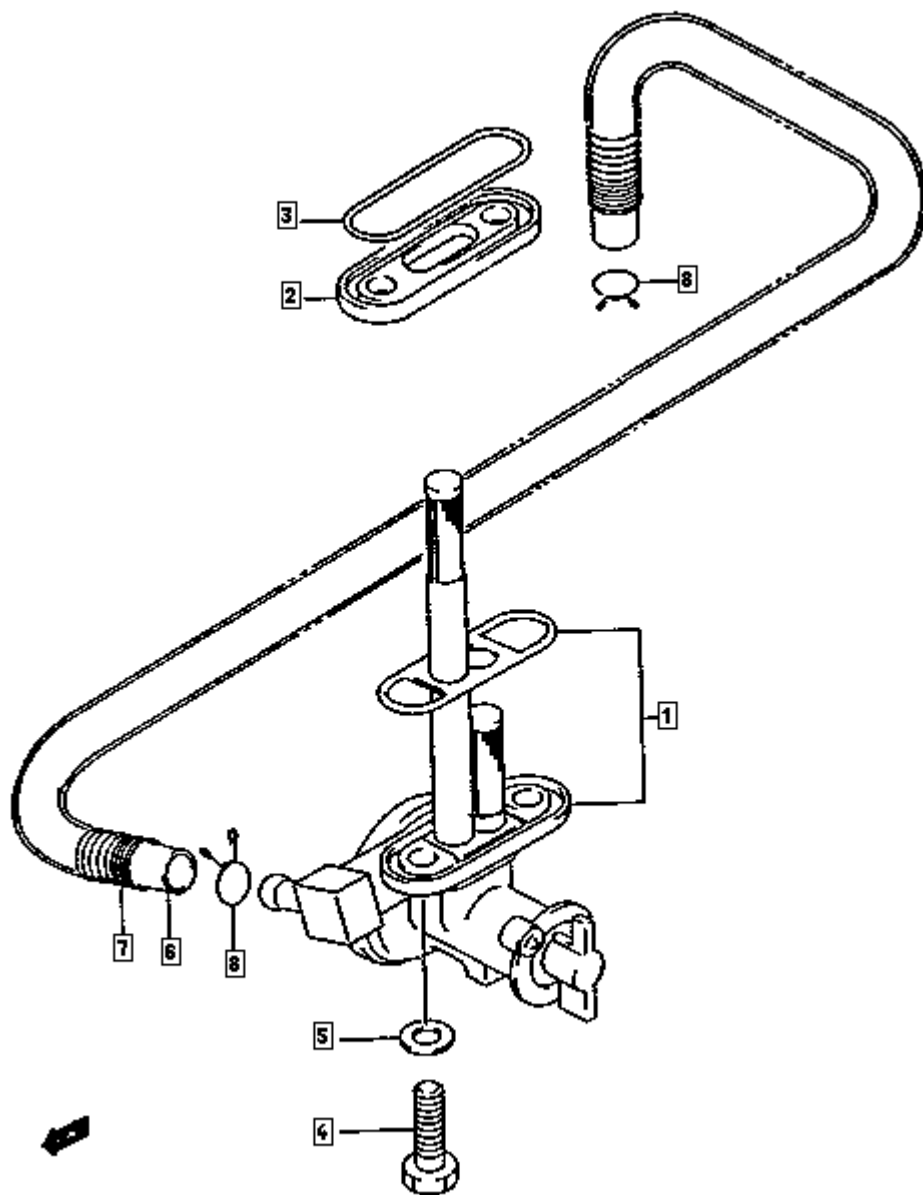
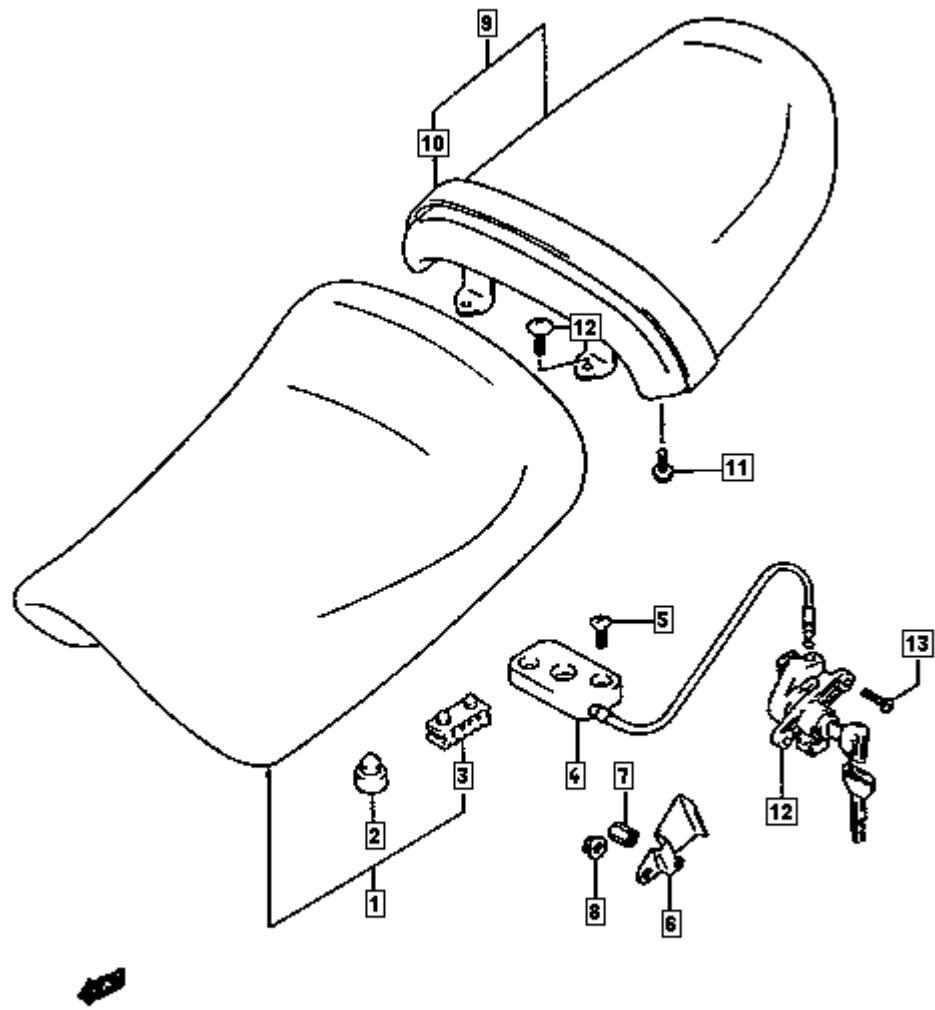
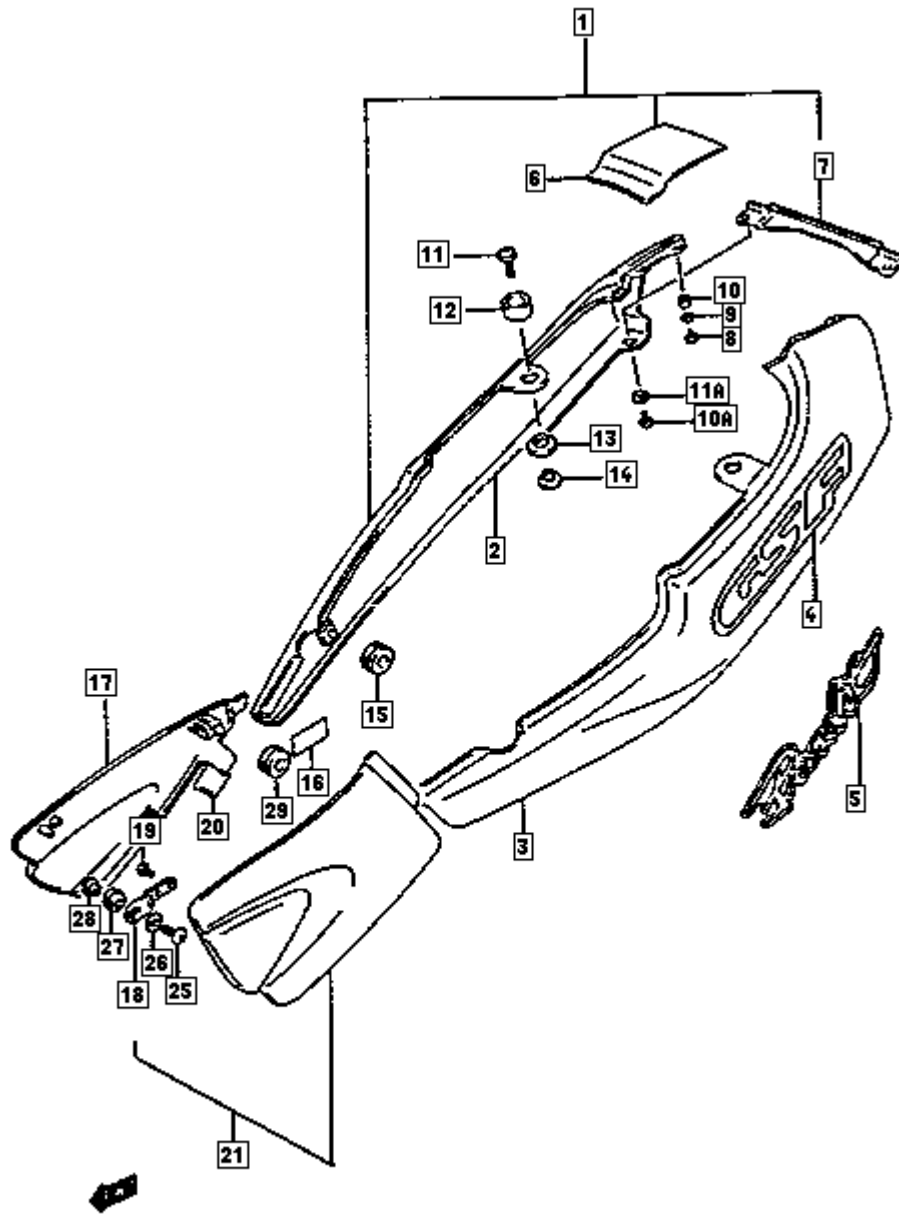
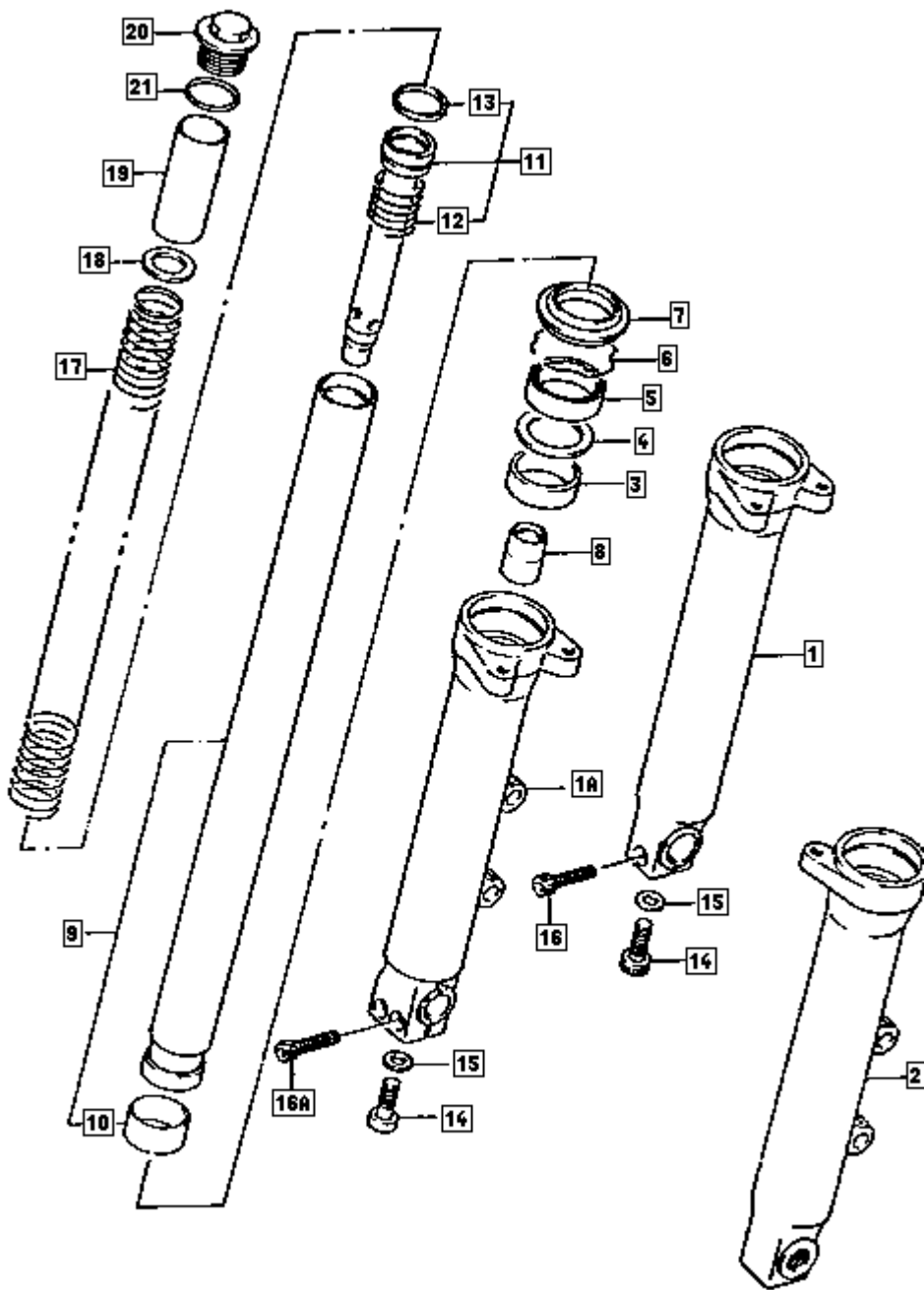


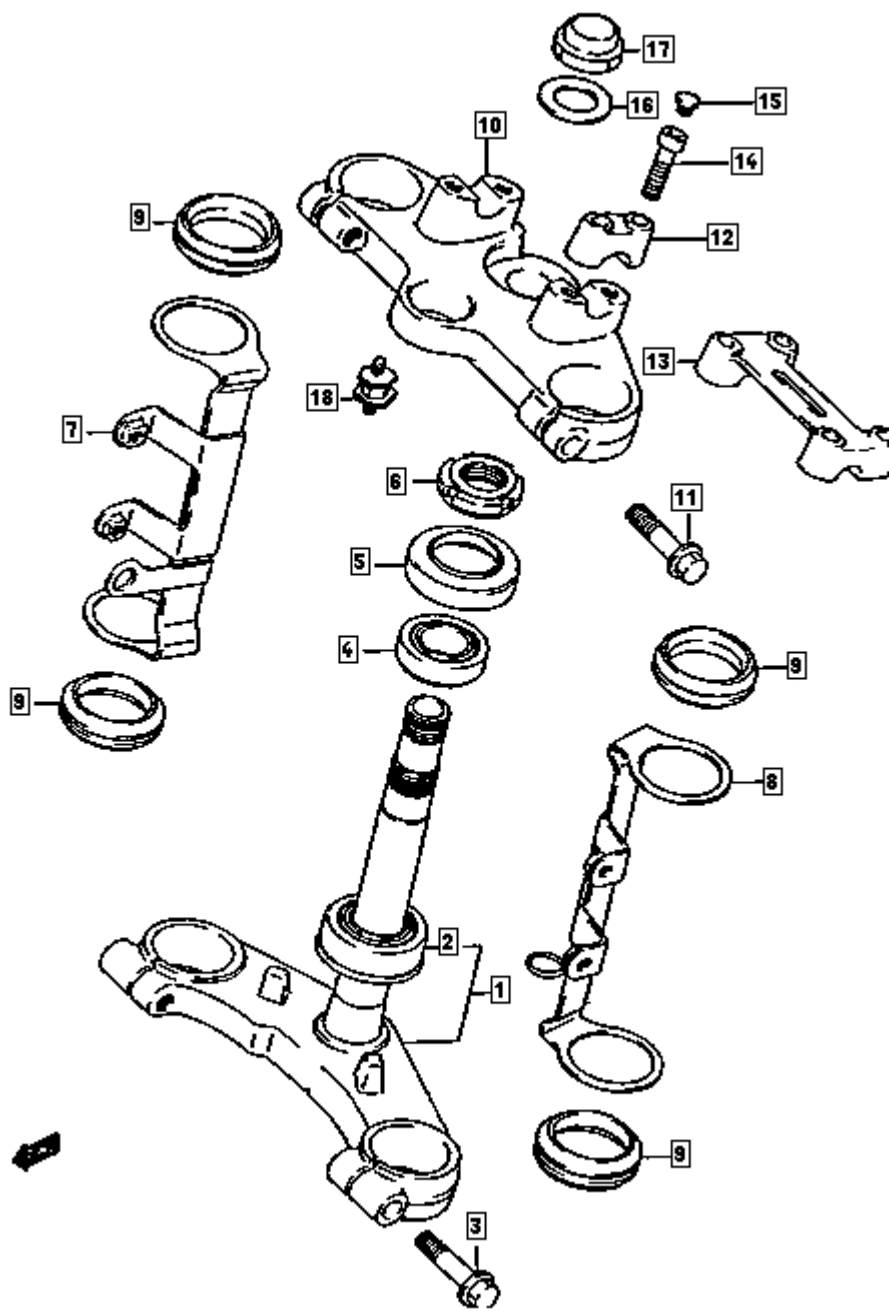
FIG. 35

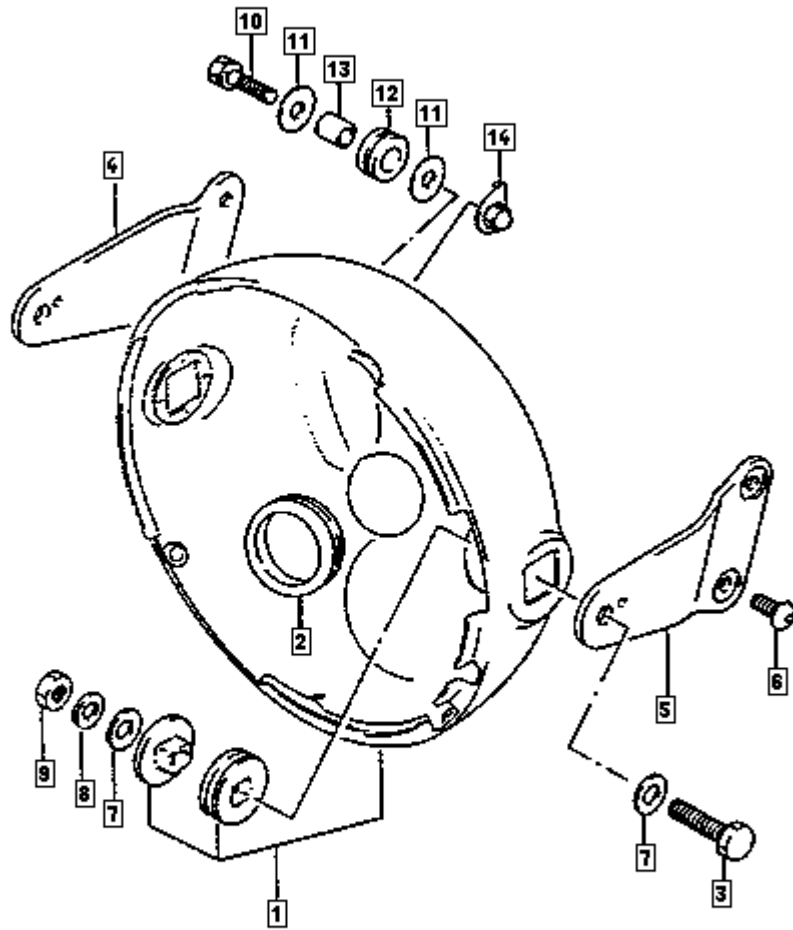


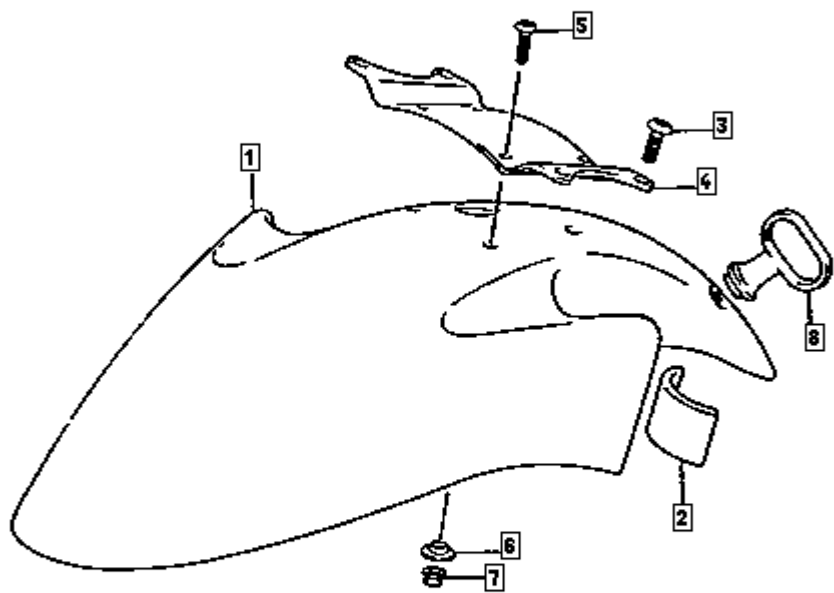


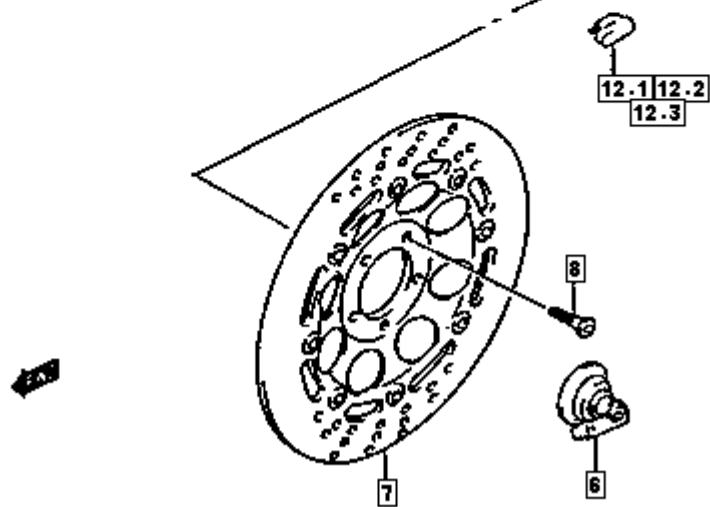
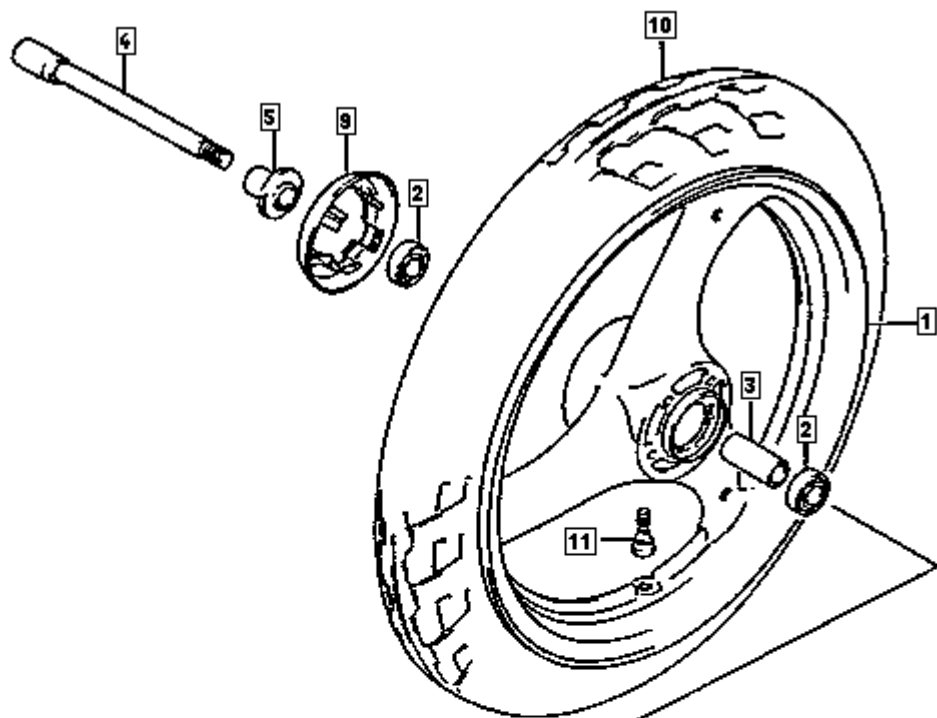


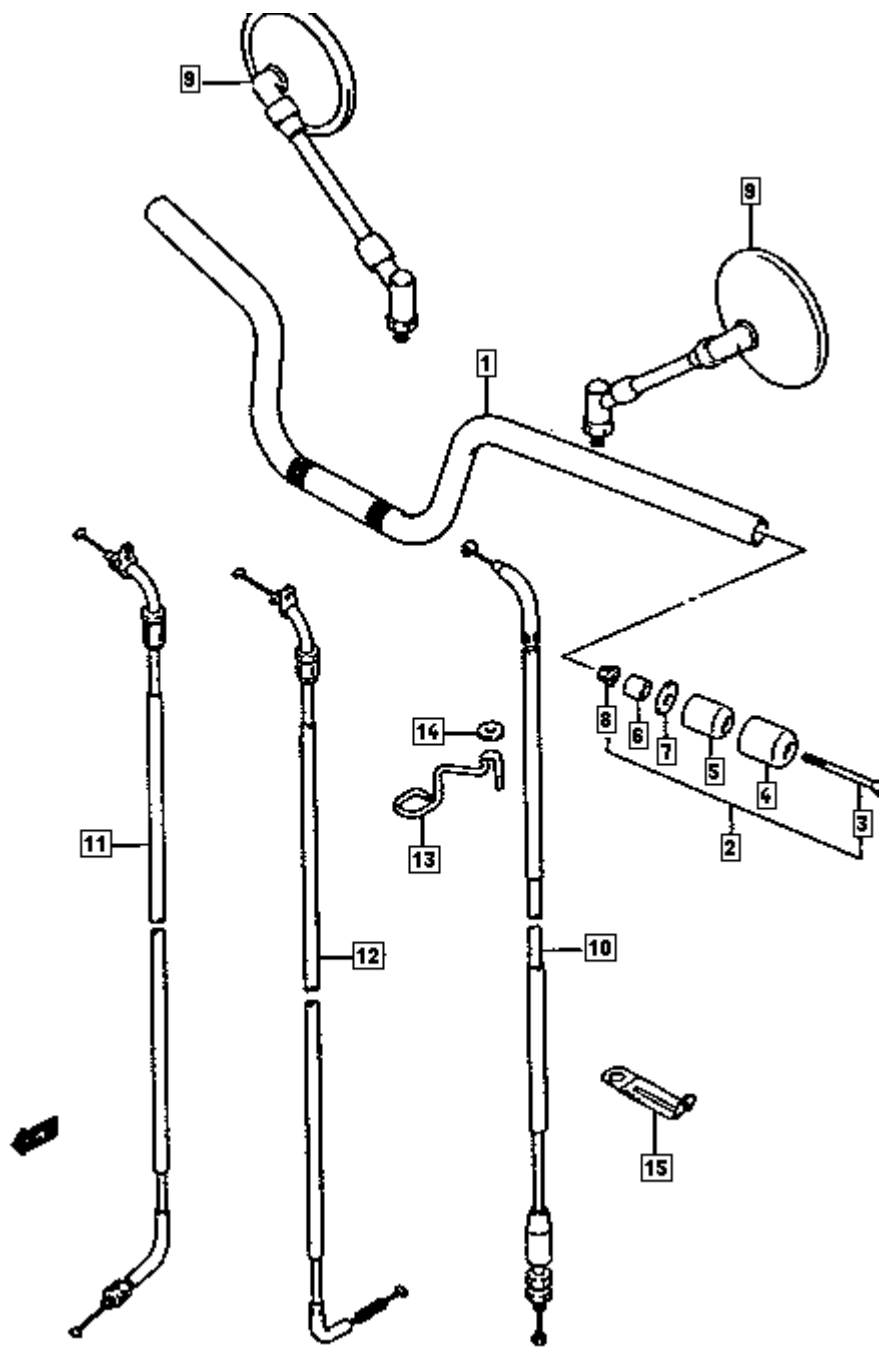


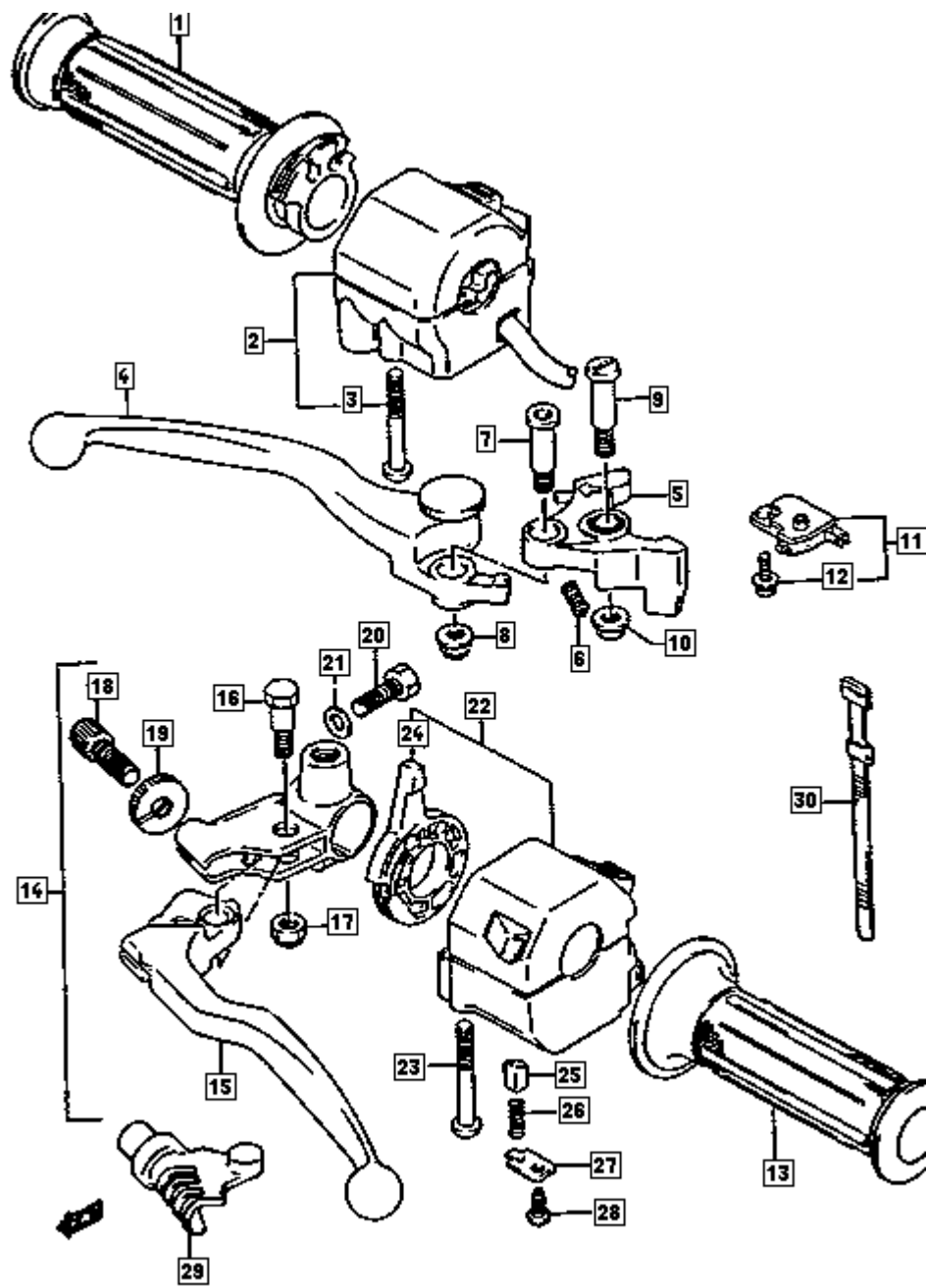




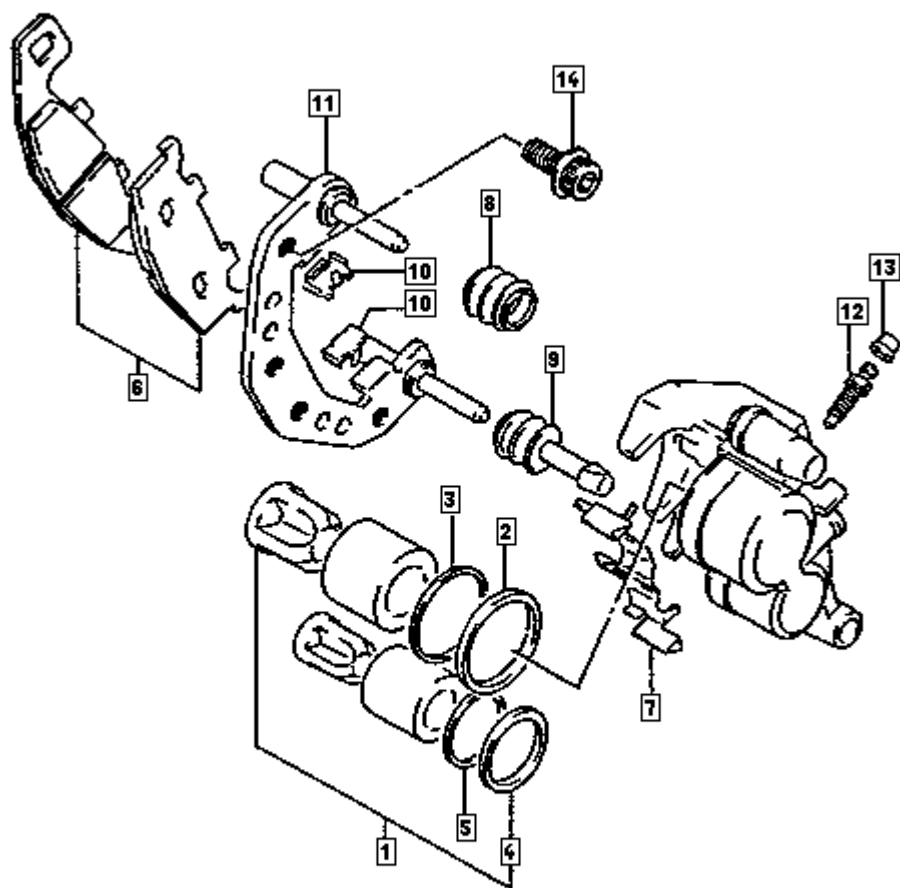


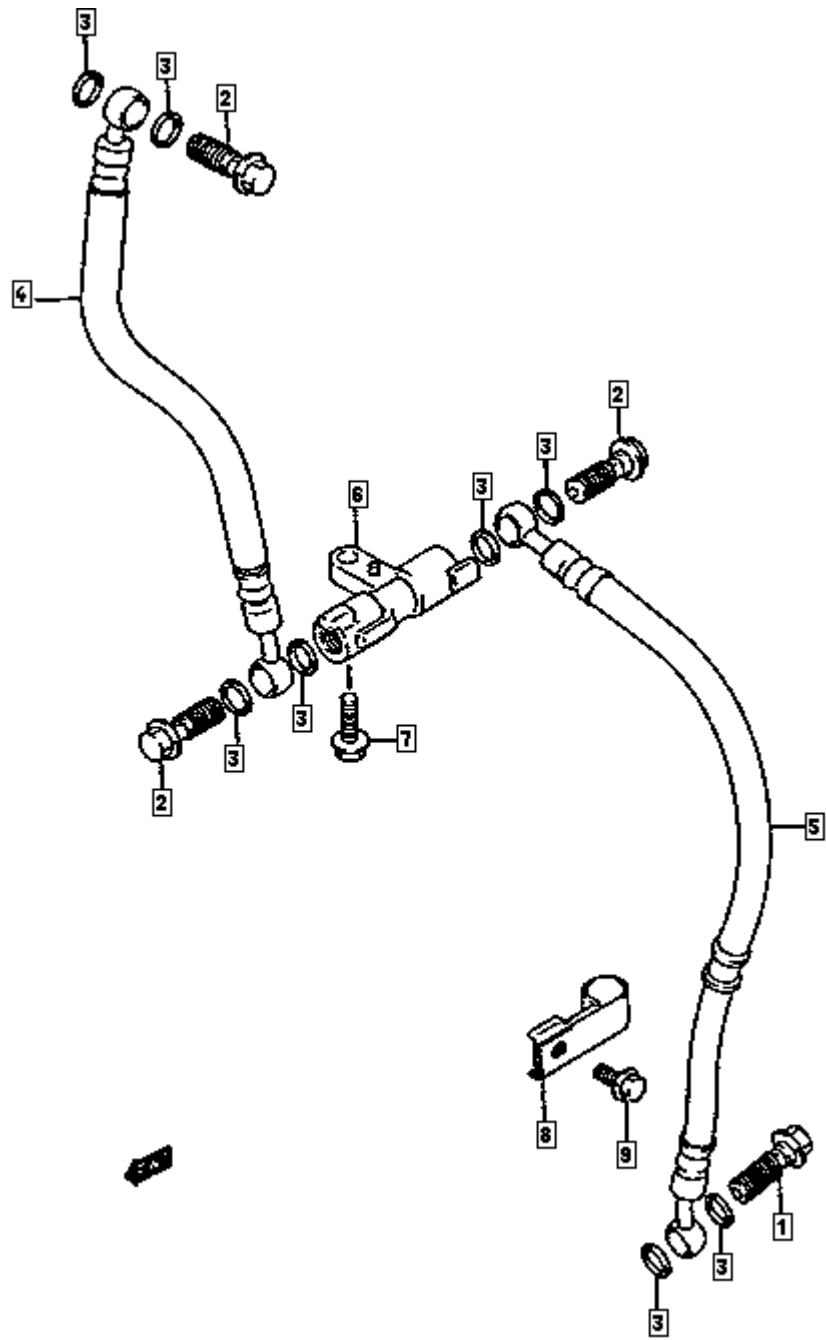


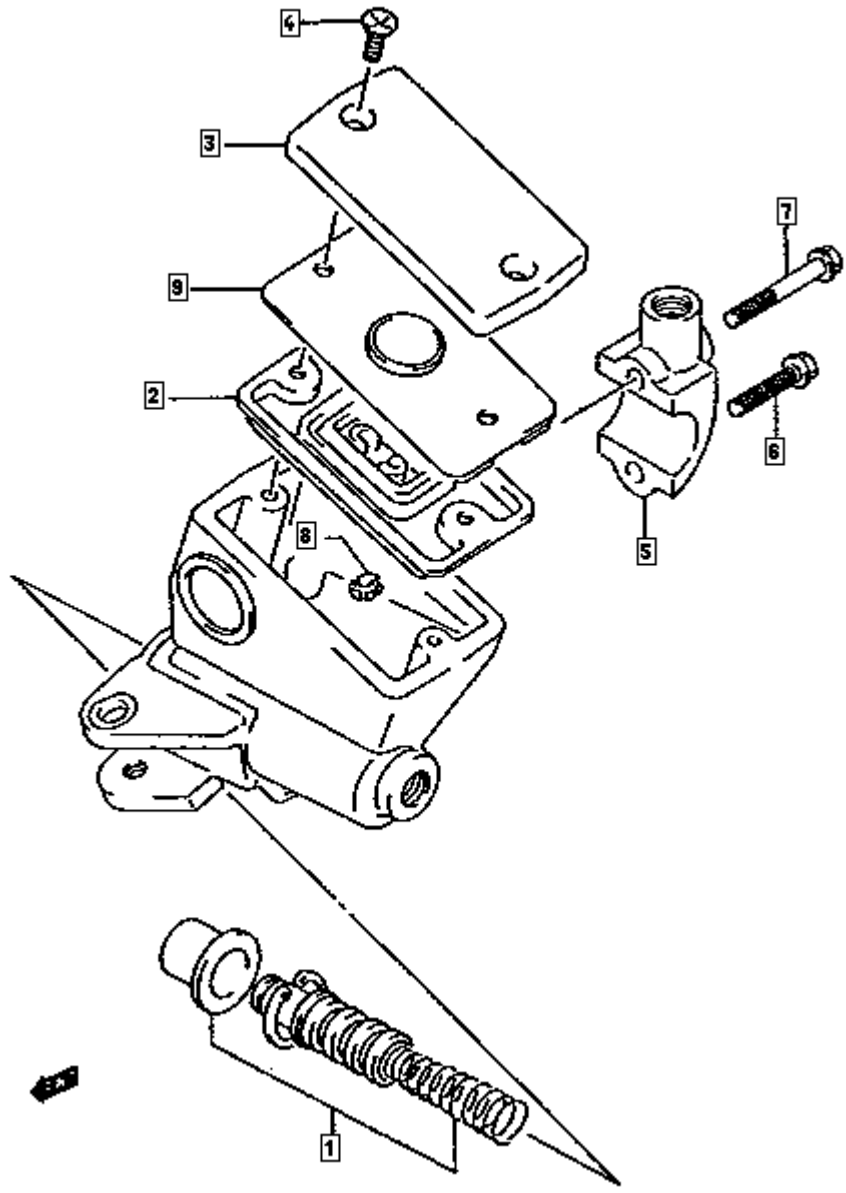


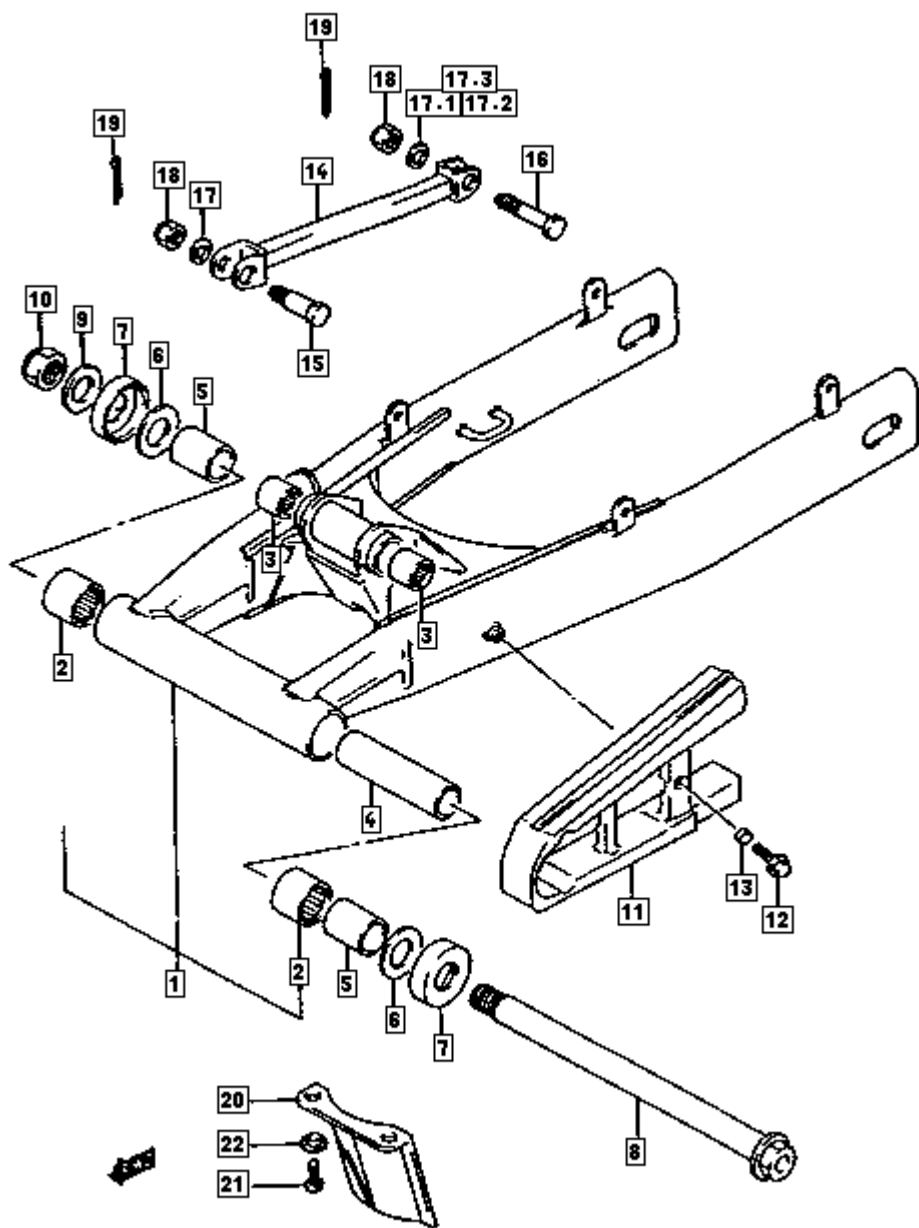


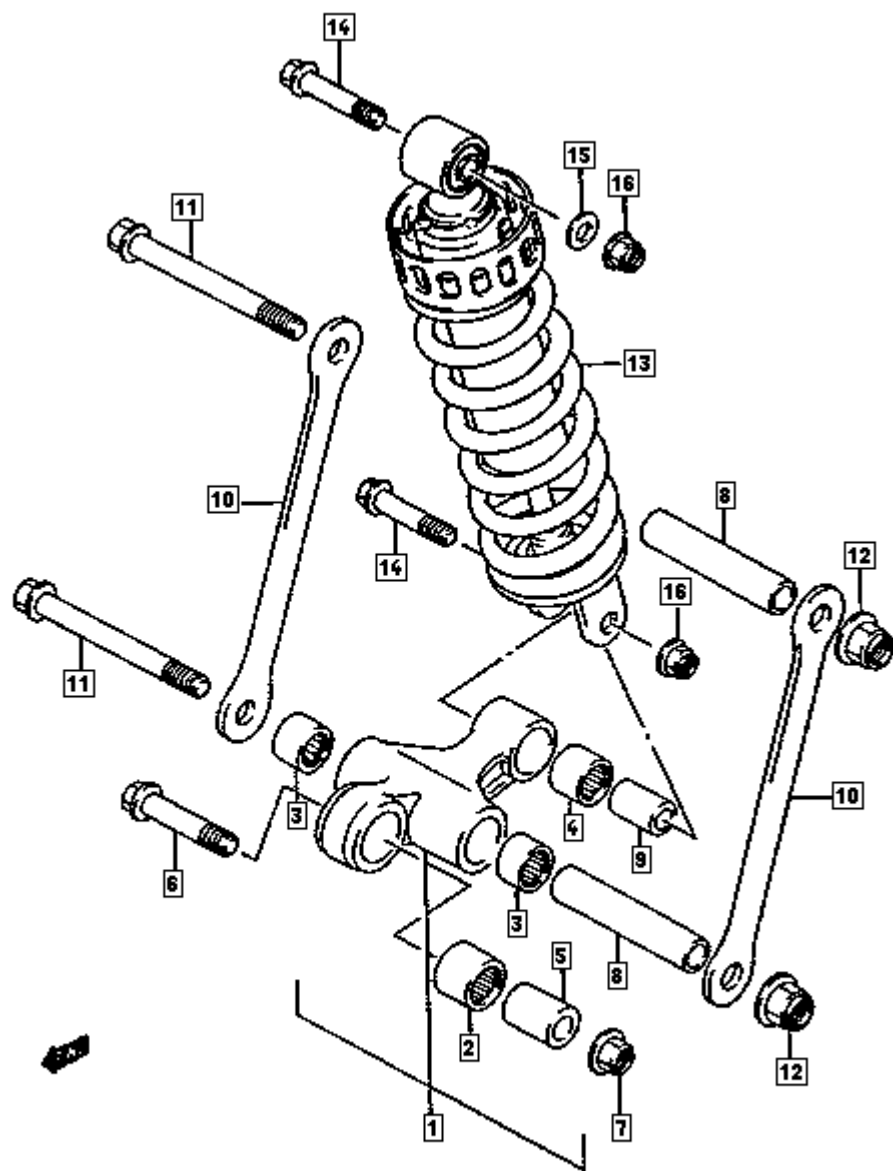
412074

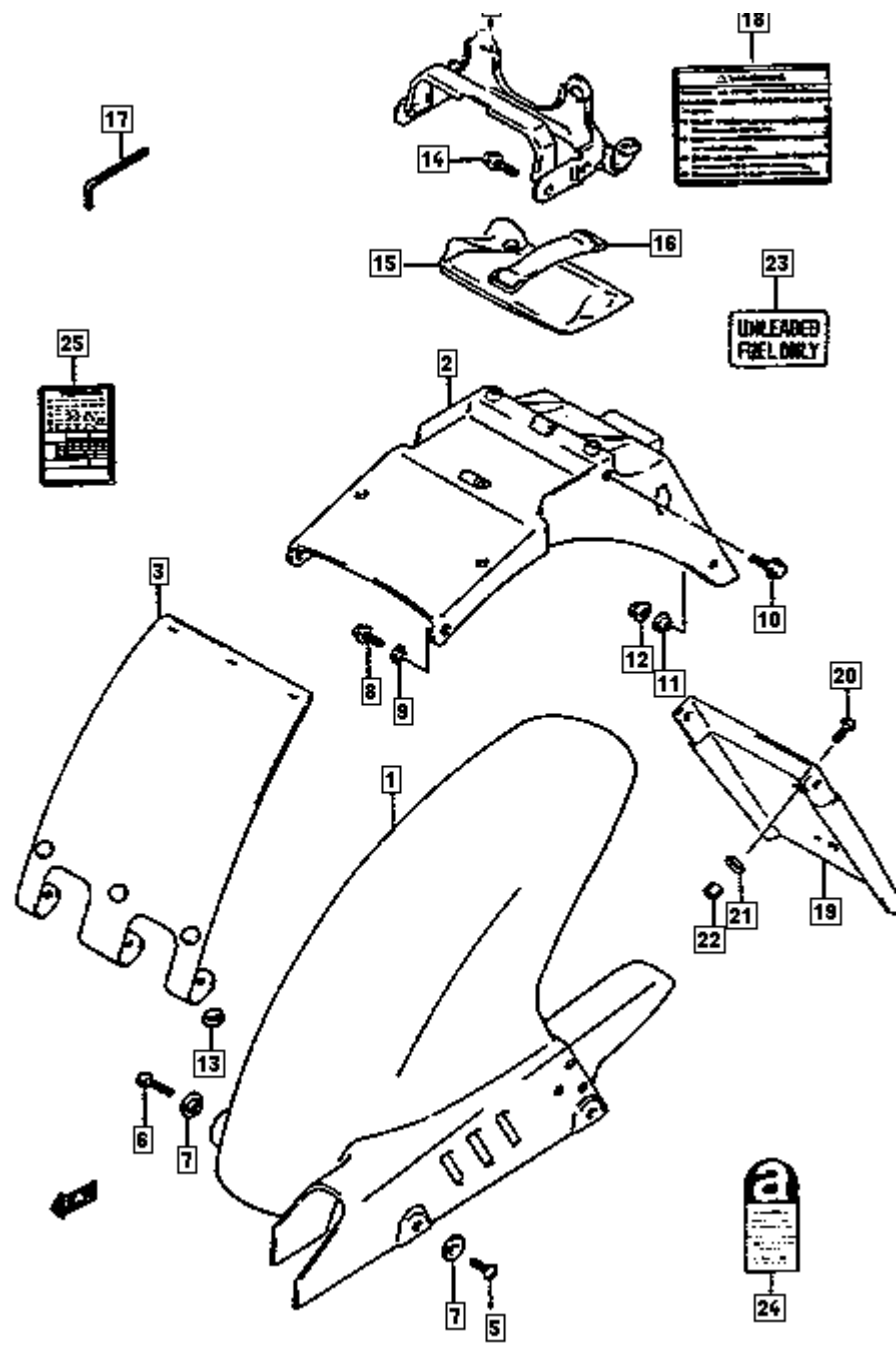












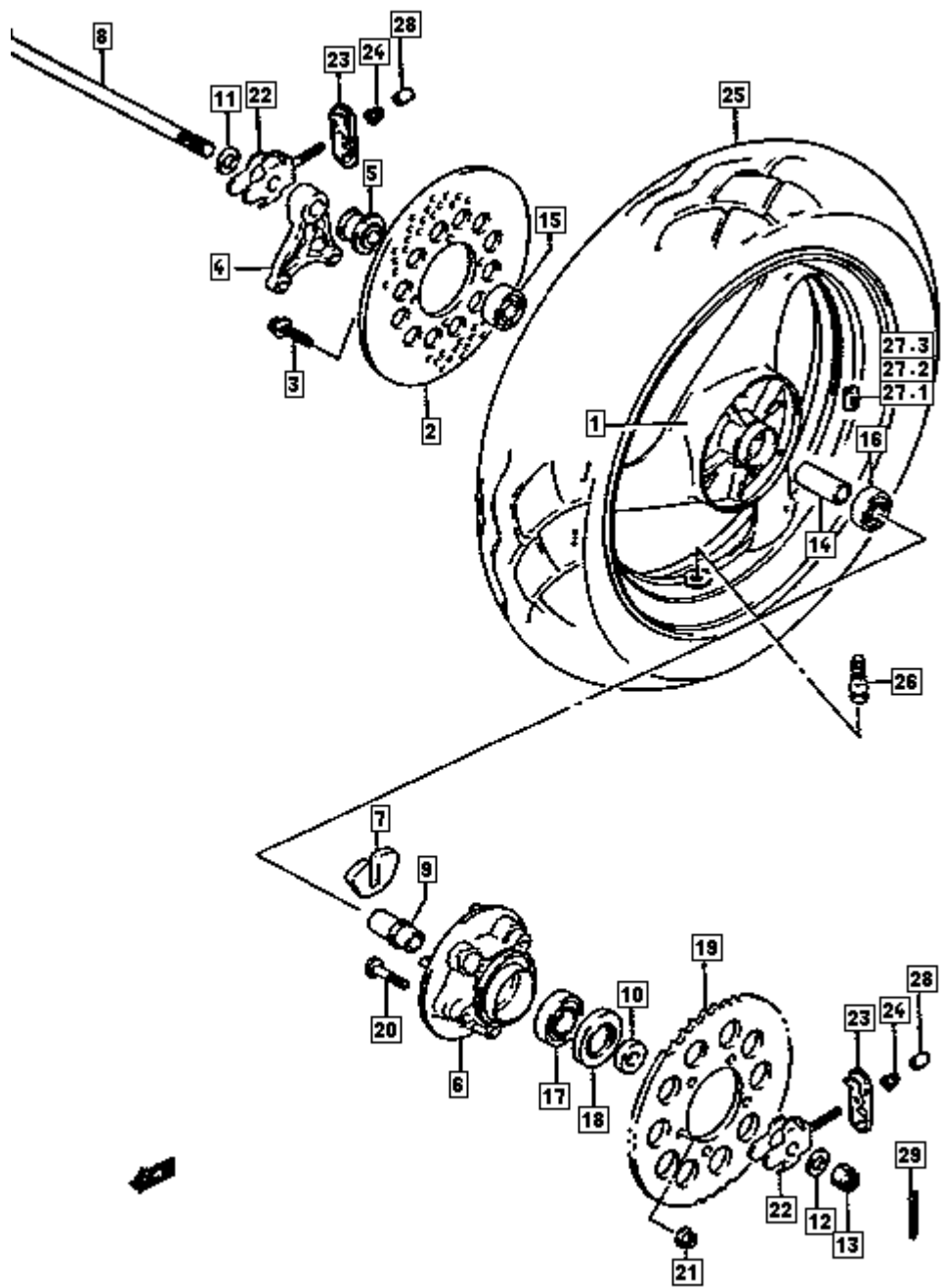


FIG. 32A

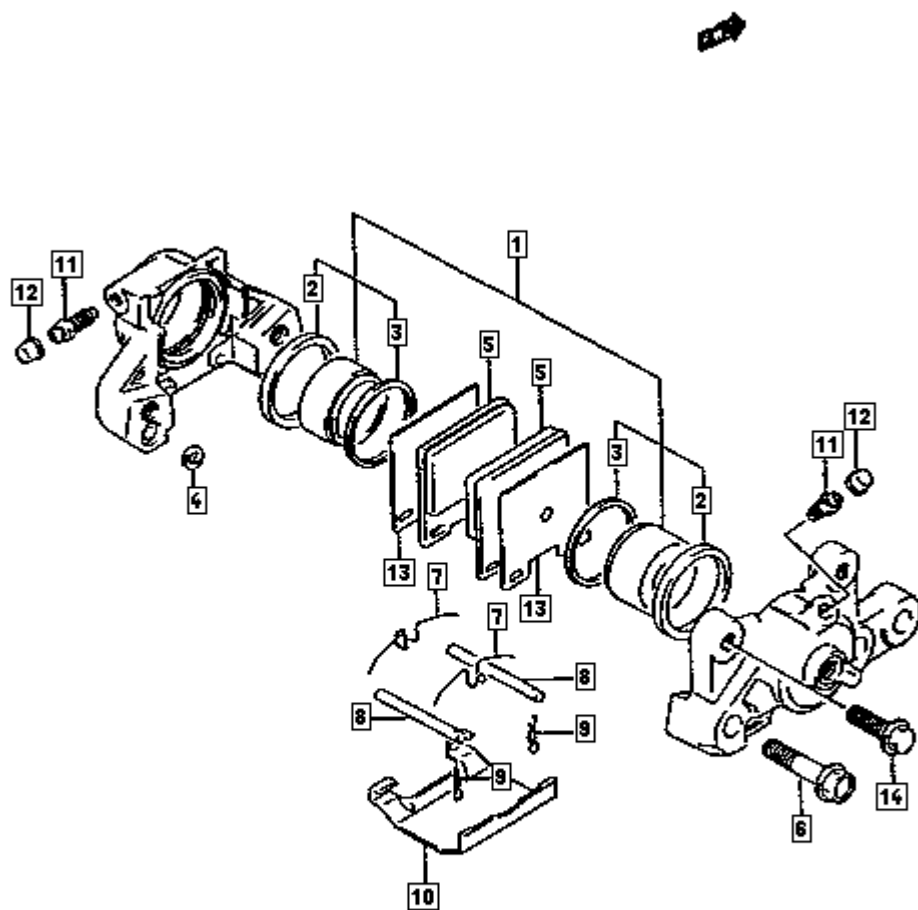


FIG. 33A

